

**APPLICATION NOTE
FOR
PA.25.A ANTENNA INTEGRATION**



TABLE OF CONTENTS

1. BASICS	3
2. APPLICATIONS	4
3. IMPEDANCE	4
4. BANDWIDTH	5
5. GAIN	5
6. POLARIZATION	6
7. EFFICIENCY	7
8. GROUND PLANE EFFECTS	8
9. ISOLATION	10
10. ELECTROMAGNETIC ENVIRONMENT	10
11. ADVANTAGES	11
12. DESIGNING THE CPW	12
13. SPECIAL INTERCONNECTION LINE	22
14. TUNING	23
15. MOUNTING	26
16. MAJOR NO-NO'S	31

1. BASICS

The PA.25 is a Monopole-PIFA SMD antenna. Knowledge and design of the best environment to use such an antenna is crucial to optimizing its performance and thus the RF device performance itself.

The PA.25 Planar Inverted F Antenna (PIFA) is without ground plane behind the antenna structure, with rectangular planar elements located in a ceramic substrate, with a short circuiting plate and a feeding mechanism. The product is SMD process compatible and delivered in tape and reel, making a unique highest performance and practical solution for current market needs.

The antenna uses the main board ground plane as its ground plane. The size of the ground plane plays an important role in the antenna efficiency and is related to the wavelength, having more effect at low frequencies. The optimal size for a ground plane is 40x95 mm, as in the evaluation board. However the antenna can be used for smaller ground-planes with very good results compared to any other antenna technology existing. The antenna will use as a ground plane the top and bottom layers rather than the middle ground plane layer. We recommend to fill with ground plane the top and bottom layers as much as possible (discussed later on this document).

The antenna/ground combination will behave as an asymmetric dipole, the differences in current distribution on the two-dipole arms being responsible for some distortion of the radiation pattern, especially at high frequencies, but keeping the omni-directional properties.

This design application note is intended to help the antenna integrator understand the relevant parameters affecting the antenna performance. Taoglas recommends that the integrator strictly follow the guidelines in this application note, upon your device prototype completion Taoglas offers further optimization by custom tuning and testing service of the antenna in your device, and assists you in the design process not just from the antenna perspective but also in achieving an ideal electromagnetic environment.

2. APPLICATIONS

The PA.25 is suitable for all mobile and fixed omni-directional cellular applications where internal antennas are required and where it can be placed on the shorter side of the device main-board with enough clearance to radiate efficiently.

3. IMPEDANCE

RF circuits in mobile devices should be designed for 50 Ohm characteristic impedance at the source (RF module), transmission line (PCB trace or coax cable) and load (antenna). In practice sometimes the characteristic impedance of the circuit is not 50 Ohms at different transmitting and receiving bands. The antenna impedance needs to be changed to match the actual characteristic impedance of the circuit. For a cellular antenna this is most effective when tuning the antenna at the over the air active testing stage in a 3D radiation chamber, when the device is turned on and using the TRP and TIS numbers as guide to find the best impedance match for the antenna.

4. BANDWIDTH

Bandwidth is defined as the frequency band below -10 dB return loss. For Penta-Band Antennas in general in small mobile devices it is more realistic to accept a minimum of -5 dB return loss at band edges for the targeted application bands (for example GSM 850/900/1700/1800/1900 and 2100 MHz). A return loss of below -10dB is targeted for the centre of the band.

The size of the ground-plane and clearance to metal components define the return loss of the PA.25. We recommend as a minimum clearance from metal parts of 20 mm, if you go below this in clearance to metal, the return loss is degraded, affecting the antenna and absorbing the energy radiated and/or detuning the antenna.

Another antenna parameter used to measure the bandwidth of an antenna is the VSWR, in principle the target is to be below 2:1, where in practice having a multi-band and challenging environments it may go to 3.5:1 at edges and the 2:1 or below is targeted at centre of the band.

5. GAIN

The gain of the antenna is closely linked to the effective surface area or volume of the antenna. The larger the surface area or volume of the antenna, the higher the gain that can be obtained; the ideal target for gain for a cellular band antenna in a mobile device which needs omni-directional radiation characteristics is peak gain of 0 dBi. Higher gain skews the radiation pattern in some directions and reduces the gain in another area of the pattern. Using ceramic materials can achieve high efficiencies in small form factors and as a consequence high gain maintaining its omni-directional radiation properties.

Care must be taken that clearances of minimum 20 mm are kept from other metal components in the device or metalized substances which will absorb or reflect the electro-magnetic radiation, substantially reducing the gain. The larger the clearance, the better the radiation characteristics of the antenna; we recommend 20 mm or more for best gain and radiation efficiency.

6. POLARIZATION

Polarization describes the orientation of the wave oscillation. All our cellular and broadband antennas are linearly polarized, to most efficiently match with the signals broadcast and the antennas mounted on cellular base-stations.

Whether it is horizontally or vertically polarized just depends on how it is mounted from your frame of reference. Standing directly in front of the antenna the linear polarization is horizontal if the antenna is placed in a horizontal position and vertical if the antennas are placed in a vertical position. In practice the radiation emitted and received by internal antennas will be to some degree cross-polarized, due to reflections from the environment and scattering in the atmosphere. Most of the cellular antennas are omni-directional, making the antenna orientation relative and therefore sometimes having no effect.

7. EFFICIENCY

Efficiency is the passive antenna measurement of choice for an omni-directional antenna for cellular mobile communication systems. These days it comes down to a simple maxim, the higher the efficiency the better the antenna.

In general 20% efficiency or higher at all bands is good enough for worldwide mobile use. However it is recommended to always aim for 40%+ in efficiency if this antenna must pass operator approvals after PTCRB in the US, especially where AT&T approval is required. In this case a ground-plane length of 60 mm or above should be used where possible. Lower ground-plane lengths may still pass approvals but with less certainty. Higher efficiency also translates into better device performance in weak signal areas and lower battery consumption.

Efficiency of the antenna directly relates to the TRP/TIS results of a device in OTA testing if the module has 50 Ohm impedance. However it is only one factor and care must be taken to not single out antenna efficiency as the only reason why a device does not meet certain TRP/TIS targets. Impedance mismatches, conducted power from the module and noise can sometimes have a larger effect on TRP/TIS than the antenna efficiency itself.

8. GROUND PLANE EFFECTS

In general for a PIFA, the required PCB ground plane length should be at least one quarter ($\lambda/4$) wavelength of the lowest operating band.

- If the ground plane is much smaller than $\lambda/4$ of the lower bands, will affect the efficiency of the antenna, this mean the having problem to radiate the energy.
- If the ground plane is much longer than $\lambda/4$ of the lower bands, will affect the high frequency, this is easily observed in the efficiency graph provided for different ground plane lengths as next.
- For those devices where the length of the ground plane is larger than the optimal (95 mm), can be compensated increasing the width of the ground plane. There is no specific proportion to do this, but we can study case by case depending on your board size.
- For those devices where the length of the board is less than 60 mm, there is nothing to do to improve the antenna performance, and will have the efficiency listed in the next graph.

The PIFA antenna must be strictly allocated in one of the shortest sides of the your board, the electromagnetic fields travel parallel to the largest side of the board, having the perfect condition to radiate the energy, not following this recommendation will degrade the antenna performance drastically. Basically in terms of PA.25 performance a larger ground-plane improves return loss and efficiency, but having the max-optimal length at 95 mm (without area for the antenna), when the width is 40 mm and a minimal recommended of 60 mm for high efficiency applications.

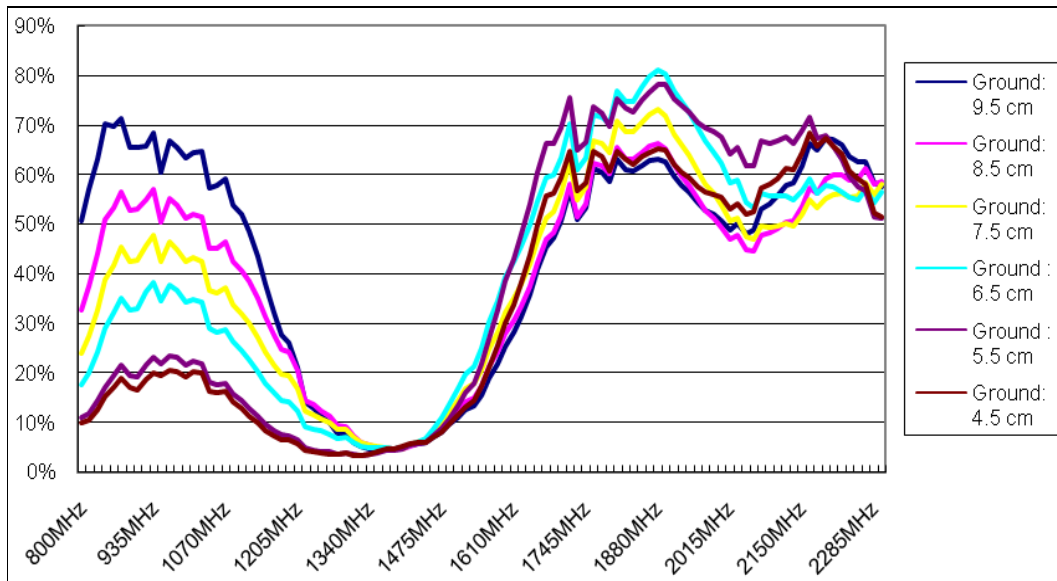

Figure 1. Efficiency at different lengths of ground plane.

The antenna uses more the ground plane that is in the top and bottom layer, rather than the ground plane in the middle GND layer. RF theory does not follow the traditional AC/DC laws; here is where Maxwell shifts Kirchhoff. It's important that you must fill with ground plane as much you can the top and bottom layer, having several via holds to interconnect the ground plane in the 3 layers (top, bottom and GND layer). Also it's important for the Co-Planar Waveguide (CPW) transmission line discussed later.

On the top and bottom layers of main board, can be allocated as much components as needed, but trying to fill all the left area with ground plane having continuity along the 2 layers. For those places where the ground plane cannot be continued, insert via holes to interconnect with the middle layer ground plane and/or the ground plane at the bottom layer.

9. ISOLATION

Isolation is a measure of coupling between two different antennas. In general care should be taken to ensure isolation between all antennas in a device. The easiest and by far most effective method is to place them as far away from each other as possible.

For example, in a CDMA diversity antenna plan the target is to get -10dB isolation between the main and the auxiliary antenna. Greater isolation can be achieved by using different polarizations on the two antennas. For example the main antenna can be positioned horizontally and the auxiliary antenna vertically. In practice this is difficult for omni-directional internal cellular antennas as there is cross-polarization of the waves occurring. So the normal solution is to keep the distance from both antennas as far away as possible. Is preferred the antenna cable should not cross over or come close to the other's antenna.

Testing is carried by sending a signal in one antenna and measuring the power of the signal at the other antenna, using the S21 method. There should be a 10dB or more difference between the transmit and the receive signal. The easiest method is to keep moving the two antennas farther from each other until the target isolation is achieved.

10. ELECTROMAGNETIC ENVIRONMENT

Close proximity to components or housing affects the electrical performance of all antennas. When placed on a non-conductive area of the board, in most cases ideally there should be clearance of 20 mm in all directions from metal components for maximum efficiency. A reduction in the efficiency of the antenna and a shift in tuned frequency will be observed if these clearances are not adhered to. Proximity effects will also have an adverse effect on the radiation pattern of the antenna. Device housings should never be metal and/or coated with EMI absorption material.

For the PA.25 we recommend 2 mm of clearance from enclosure for best performance. 2mm to 1mm is still reasonable. Below 1mm will cause major issues like antenna mounting layout to be re-designed to try to compensate for large detuning effects.

11. ADVANTAGES

- Compact volume, minimum footprint - It can be placed into the housing of the mobile device, unlike most whip/rod/helix antennas.
- It can be mounted directly on edge of device main-board.
- Transmission losses are kept to absolute minimum resulting in much improved over the air (OTA) device performance compared to similar efficiency cable and connector antenna solutions
- Reductions in probability of radiated spurious emissions compared to other antenna technologies are observed when using the PA.25 and strictly following this application note layout
- Achieves moderate to high gain in both vertical and horizontal polarization planes. This feature is very useful in certain wireless communications where the antenna orientation is not fixed and the reflections or multipath signals may be present from any plane. In those cases the important parameter to be considered is the total field strength, which is the vector sum of the signal from the horizontal and vertical polarization planes at any instant in time.
- Labour saving SMT – also ensures higher quality yield rate
- No antenna tooling cost for customer.

12. DESIGNING THE CPW

The CPW (Co-Planar Waveguide) design is only from the GSM Module to the edge of the ground plane. Beyond the edge of the ground plane to the antenna is not a CPW, this is a special interconnection line. Depending on the thickness and number of layers of the board, the CPW can be adjusted to maintain a 50 Ohms +/- 10% system.

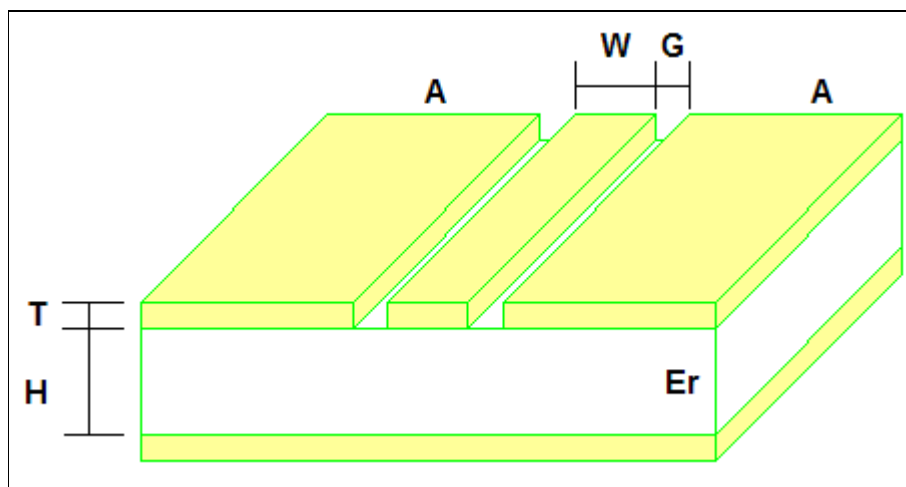

Figure 2. Representation of Co-Planar Waveguide (CPW).

Inputs:

- Width=1.2 mm (W)
- Gap=0.5 mm (G)
- Thickness=0.36 mm (T)
- Height=0.76 mm (H)
- Dielectric Constant=4.4 (Er)
- Conductivity= 5.88×10^7 S/m
- Loss Tangent=0.02
- Frequency=2170 MHz

Outputs:

- Impedance=50.02 Ohms
- Loss=1.51 dB/m

The CPW can be adjusted for Gap, Width and Height. The Gap and Width we recommend changing the values but not too far away from those proposed here, so as to avoid abrupt changes in different widths and separations. The CPW can be designed in between the TOP and BOTTOM Layers or in between the TOP and GND Middle Layers.

Depending on the selected pair chosen, the height can be changed to obtain a 50 ohms system depending on each individual project need. In between the pair chosen must be free of other layers, traces, etc, having a cutout where the CPW path is designed. As in real life we present different scenarios when designing the CPW:

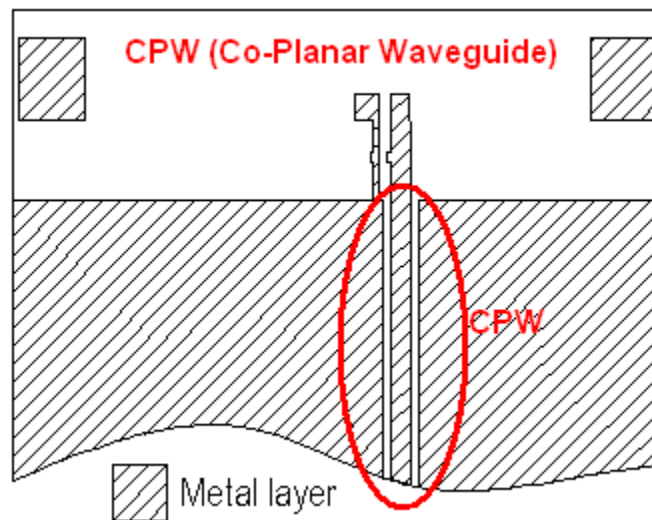

Figure 3. Co-Planar Waveguide (CPW).

Case 1

The CPW was designed in between the TOP and GND middle layers

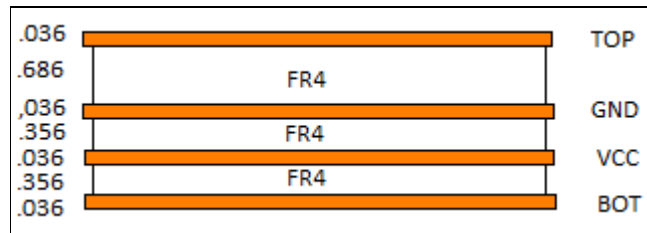

Figure 4. Case1of CPW.

Inputs:

- Width=1.2 mm (W)
- Gap=0.5 mm (G)
- Thickness=0.36 mm (T)
- Height=0.686 mm (H)
- Dielectric Constant=4.4 (Er)
- Conductivity=5.88x10⁷ S/m
- Loss Tangent=0.02
- Frequency=2170 MHz

Outputs:

- Impedance=48.53 Ohms
- Loss=1.56 dB/m

Case 2

The CPW was designed in between the TOP and GND Layers. A cutout in the VCC Layer must be placed where the CPW path is designed. This will not cause a drastic effect on the impedance of the transmission line. The dimensions are:

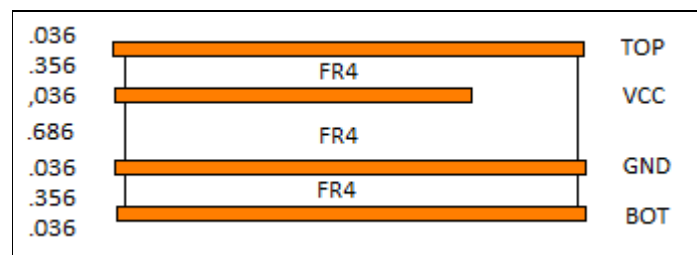

Figure 5. Case 2 of CPW.

Inputs:

- Width=1.2 mm (W)
- Gap=0.4 mm (G)
- Thickness=0.36 mm (T)
- Height=1.07 mm (H)
- Dielectric Constant=4.4 (Er)
- Conductivity= 5.88×10^7 S/m
- Loss Tangent=0.02
- Frequency=2170 MHz

Outputs:

- Impedance=53.42 Ohms
- Loss=1.5 dB/m

Note that the Height is the gap from the TOP and GND Layers. In order to better match the CPW the Gap was changed to 0.4mm. The change in Gap must be done only on the CPW.

Case 3

The CPW was designed in between the TOP and BOTTOM Layers. Where the CPW path is designed there must exist a cutout in the VCC and GND Layers. If not it will cause a drastic effect on the impedance of the transmission line. The dimensions are:

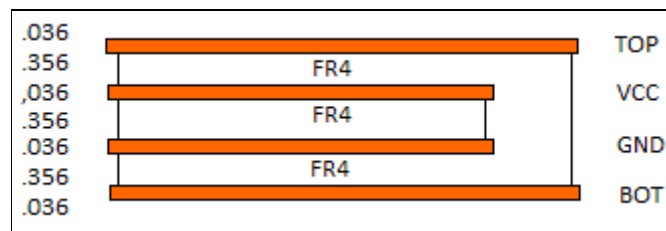

Figure 6. Case 3 of CPW.

Inputs:

- Width=1.4 mm (W)
- Gap=0.4 mm (G)
- Thickness=0.36 mm (T)
- Height=1.14 mm (H)
- Dielectric Constant=4.4 (Er)
- Conductivity= 5.88×10^7 S/m
- Loss Tangent=0.02
- Frequency=2170 MHz

Outputs:

- Impedance=51.24 Ohms
- Loss=1.46 dB/m

Case 4

The CPW was designed in between the TOP and GND Layers.

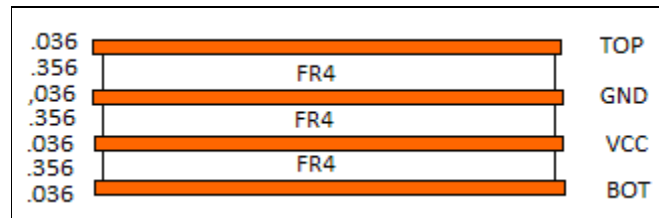

Figure 7. Case 4 of CPW.

Inputs:

- Width=0.5 mm (W)
- Gap=0.3 mm (G)
- Thickness=0.36 mm (T)
- Height=0.356 mm (H)
- Dielectric Constant=4.4 (Er)
- Conductivity=5.88x10⁷ S/m
- Loss Tangent=0.02
- Frequency=2170 MHz

Outputs:

- Impedance=53.31 Ohms
- Loss=2.3 dB/m

Tips in designing CPW

Overall Case 4 has more losses, a thin signal trace and short height tends to create more losses and a reduction in bandwidth. To avoid abrupt impedance changes and discontinuities in the transmission line we recommend designing tapers in between the transitions of different widths. Avoiding 90 degree turns is a key in the design of the CPW, a turn must be at least with curved shape or in 45 degrees.

The ground plane aside of the center signal trace of the CPW must be from 7 to 10 times bigger to each side of the width of the signal trace, to have a consistent 50 Ohms system. The reduction in the ground plane aside of the signal trace will cause an increase in insertion losses, poor matching, and loss of the 50 Ohms system.

$$A = (7-10) \times W$$

The next figures present the layout of Case 1, Case 3 and Case 4 respectively, where the dimensions of width (W) and gap (G) were changed.

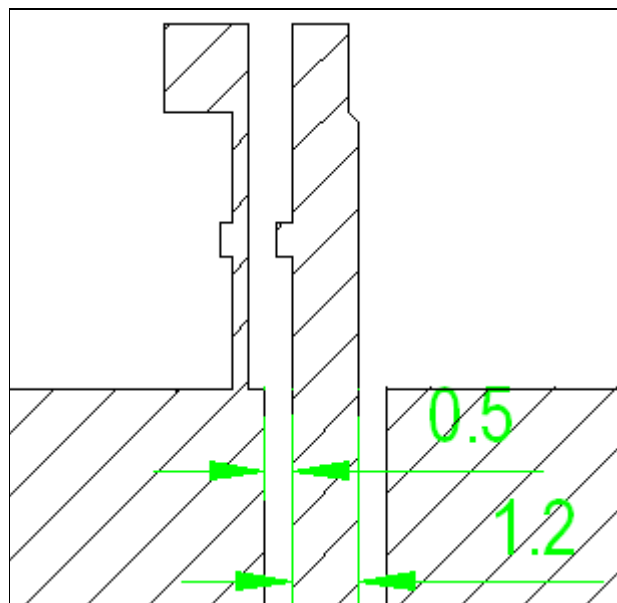

Figure 8. Layout of CPW in case 1.

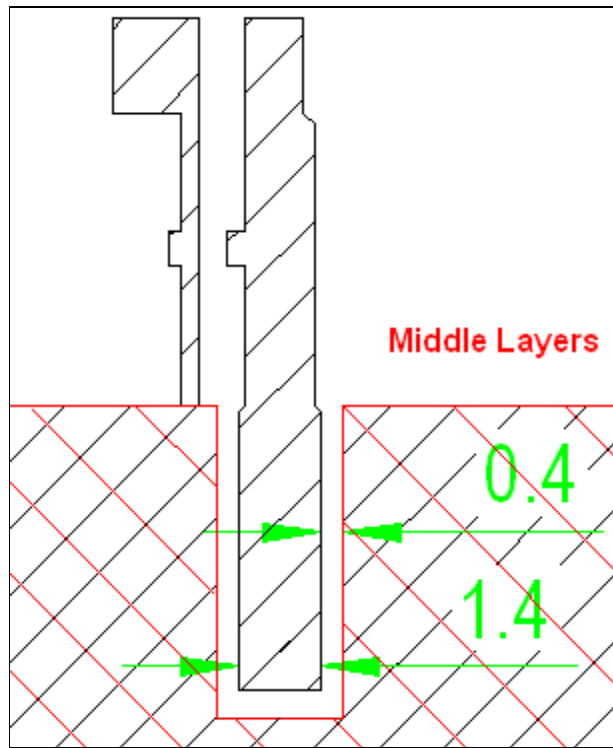

Figure 9. Layout of CPW in case 3.

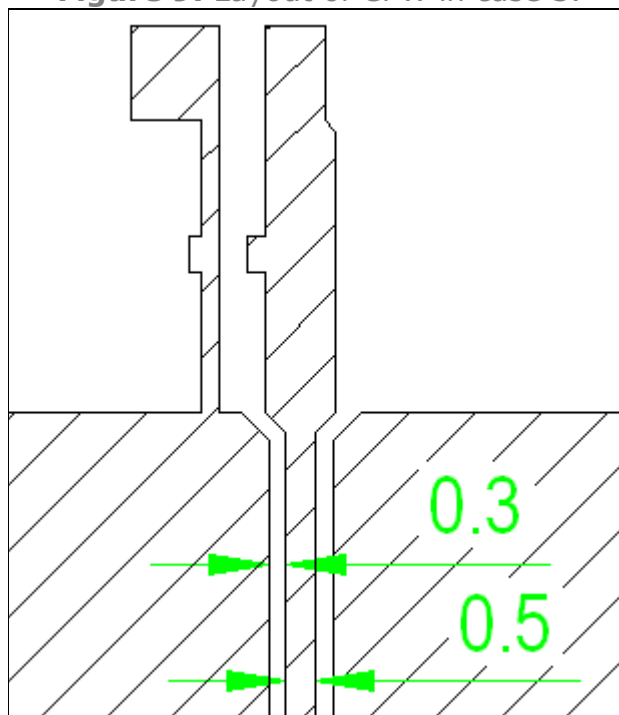

Figure 10. Layout of CPW in case 4.

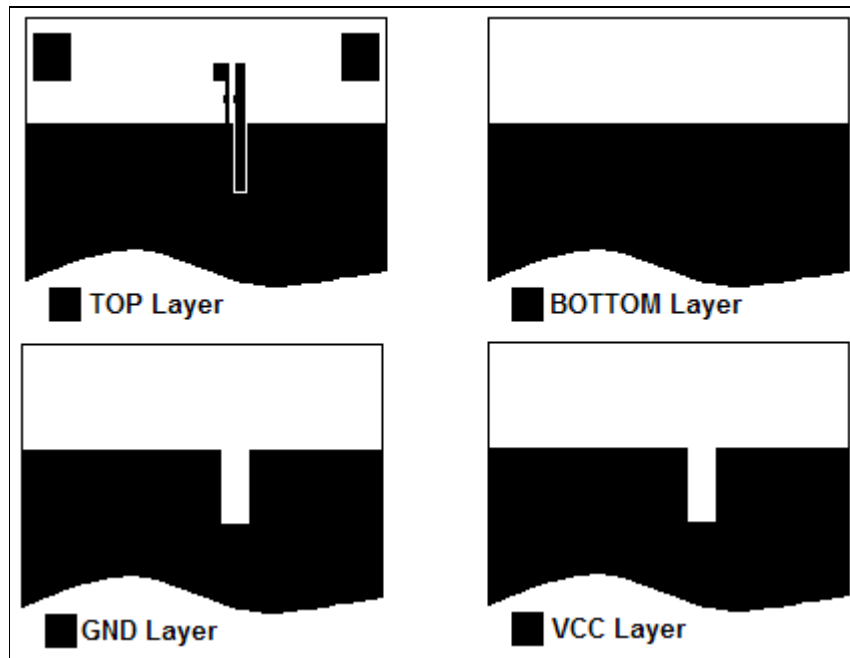

Figure 11. Layers explanation in case 3.

Finest level of CPW design.

We recommend incorporating in the design via holes at the edge of the ground plane aside of the center signal trace from the CPW. This will help to ground both layers (TOP and BOTTOM Layers, Case 3), having a consistent ground plane for the CPW, thus keeping the 50 ohms system reliable and a proper RF ground plane for the antenna. In the Cases 1, 2 and 4 the via holes in the CPW will be from TOP to BOT connecting any GND middle layers.

Making a fence around the board with via holes will result in a better shielding of the system, providing more resistance against noise issues, better ground and optimum antenna performance. This via hole fence must interconnect the ground planes in between (TOP, BOTTOM and GND Layers), plus some random via holes on the entire board. The next figure shows via holes around the CPW and fencing the board.

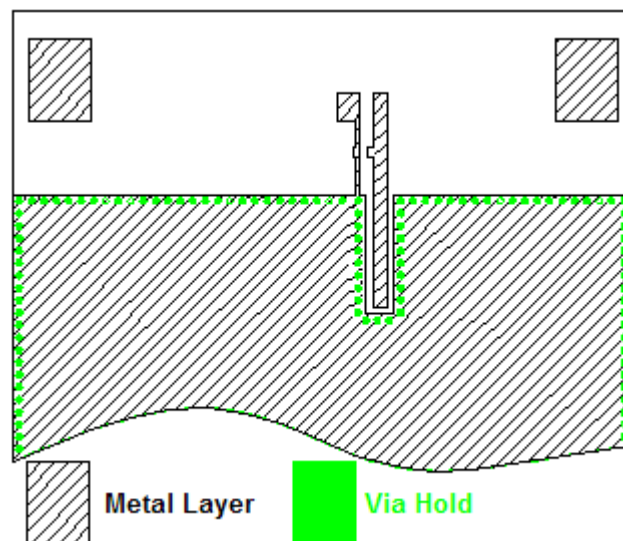

Figure 12. Via holes fence.

13. SPECIAL INTERCONNECTION LINES

The interconnection lines in between the board and the antenna is either a CPW or a traditional Microstrip. Keep these dimensions as much as possible. The thin ground connection has its purpose, do not add more ground or extend the CPW beyond the edge of the ground plane. The width of the extended signal trace, once it's outside of the edge of the CPW, can be adjusted if it is strictly necessary, but in small proportions, from 0.9 to 1.3 mm.

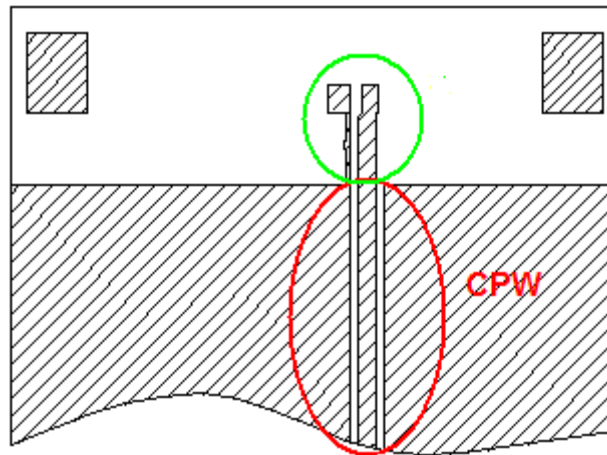

Figure 13. Interconnection lines.

14. TUNING

PIFA antennas are less susceptible to detuning from the close environment than other antennas due to their design. However tuning optimization can be carried out by. The tuning of the antenna will be made leaving the spaces for a “pi” network (S1, S2 and S3) in between the GSM module starting at the edge of the ground plane. An outside inductor is strictly mandatory (L1).

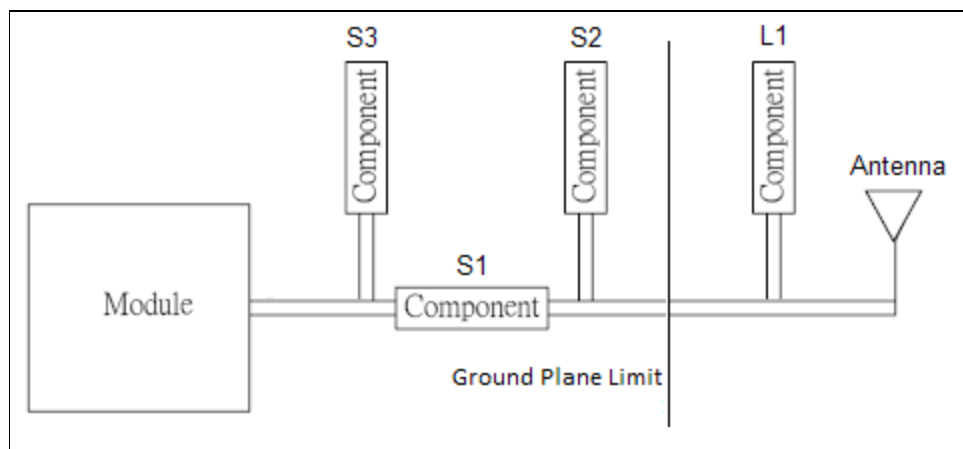

Figure 14. Matching circuit.

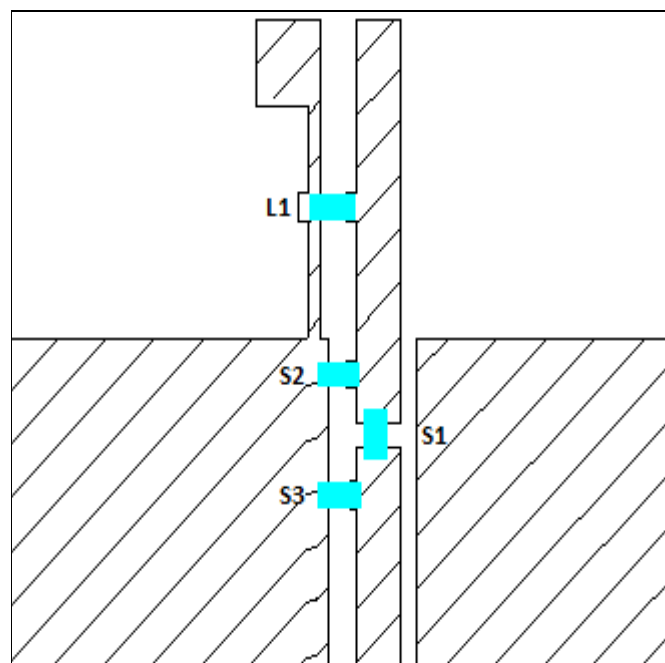

Figure 15. Layout for the Matching circuit.

Appropriate choice of matching circuit

Taoglas offers RF integration services. If the customer uses our service they can give the housing and reference PCB to Taoglas then Taoglas can carry out the necessary S11 response measurements in both magnitude and Smith Chart format of the complete system. The necessary impedance matching circuit should be designed on the customer side if he/she has access to a software modeling tool which simulates the system.

The matching circuit values obtained from this exercise can then be employed and adjusted via measurement and simulation to obtain the optimal 50 Ohm match at the frequencies of interest, establishing the type and values for the lumped components. It should be noted that impedance matching can improve the response of the antenna at certain frequencies (or bands of frequencies in the case of wideband matching circuits) but a reduction in the response at other frequencies may be observed.

The “pi” network can have inductors or capacitor combinations, any board will have a very different effect over the antenna return loss, we can not give the values for this “pi” network and in some cases it is not needed at all.

Mandatory Outside inductor

The PA.25 needs a lumped component at the antenna to obtain a 50 Ohm impedance match across the frequency bands. We recommend starting with a 2.2 nH for short ground planes (45-75 mm) and 6.8 nH for larger ground planes (80-100 mm).

Starting values for the PI network

Leave a zero Ohm resistor in series in the “pi” matching network (S1) and no lumped components in parallel (S2 and S3). Further optimization could be done as part of a matching circuit to determine if more components are necessary in the “pi” network, but cannot be determined before, until we test the board with the antenna on it.

15. MOUNTING

The next figure shows the layout for the antenna mounting:

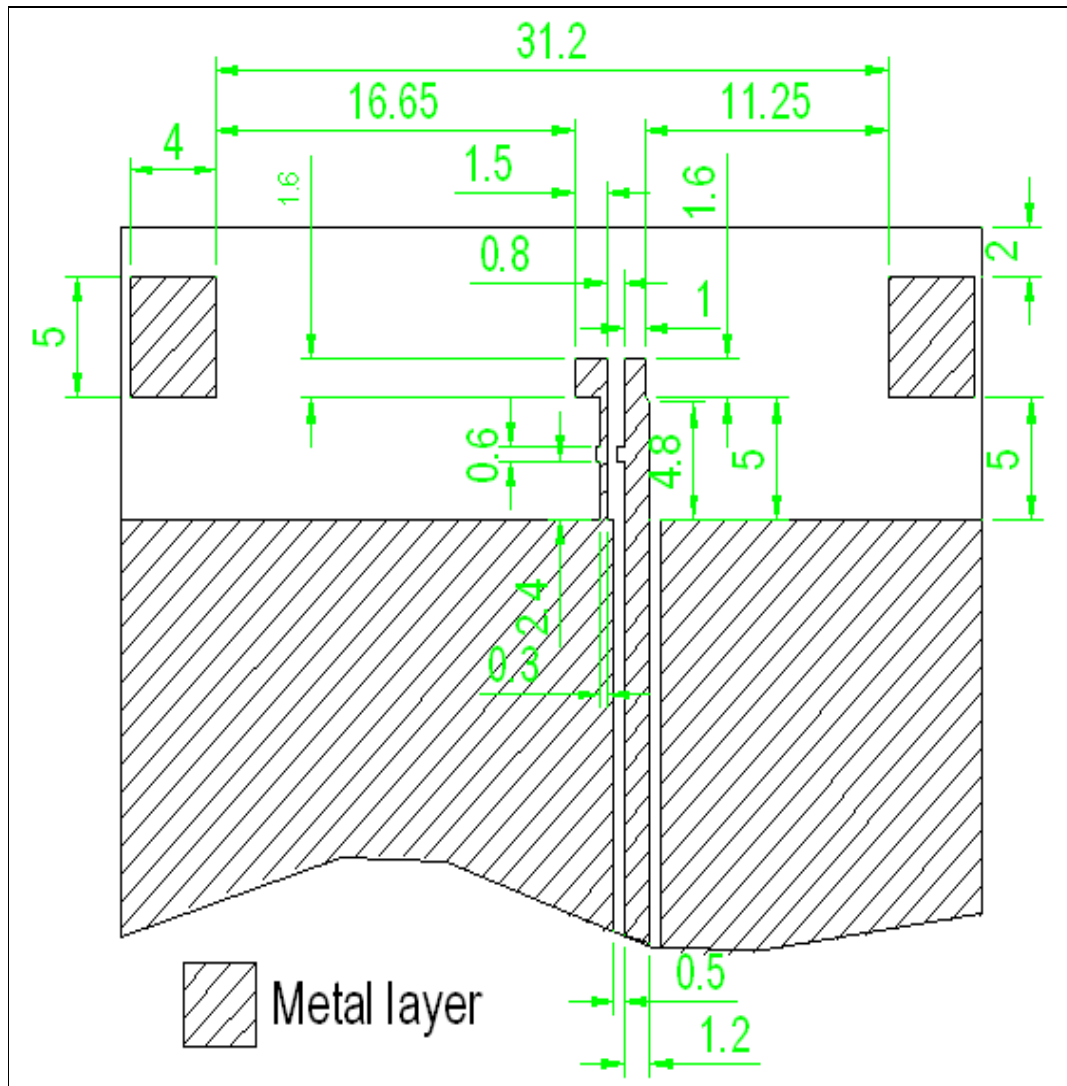
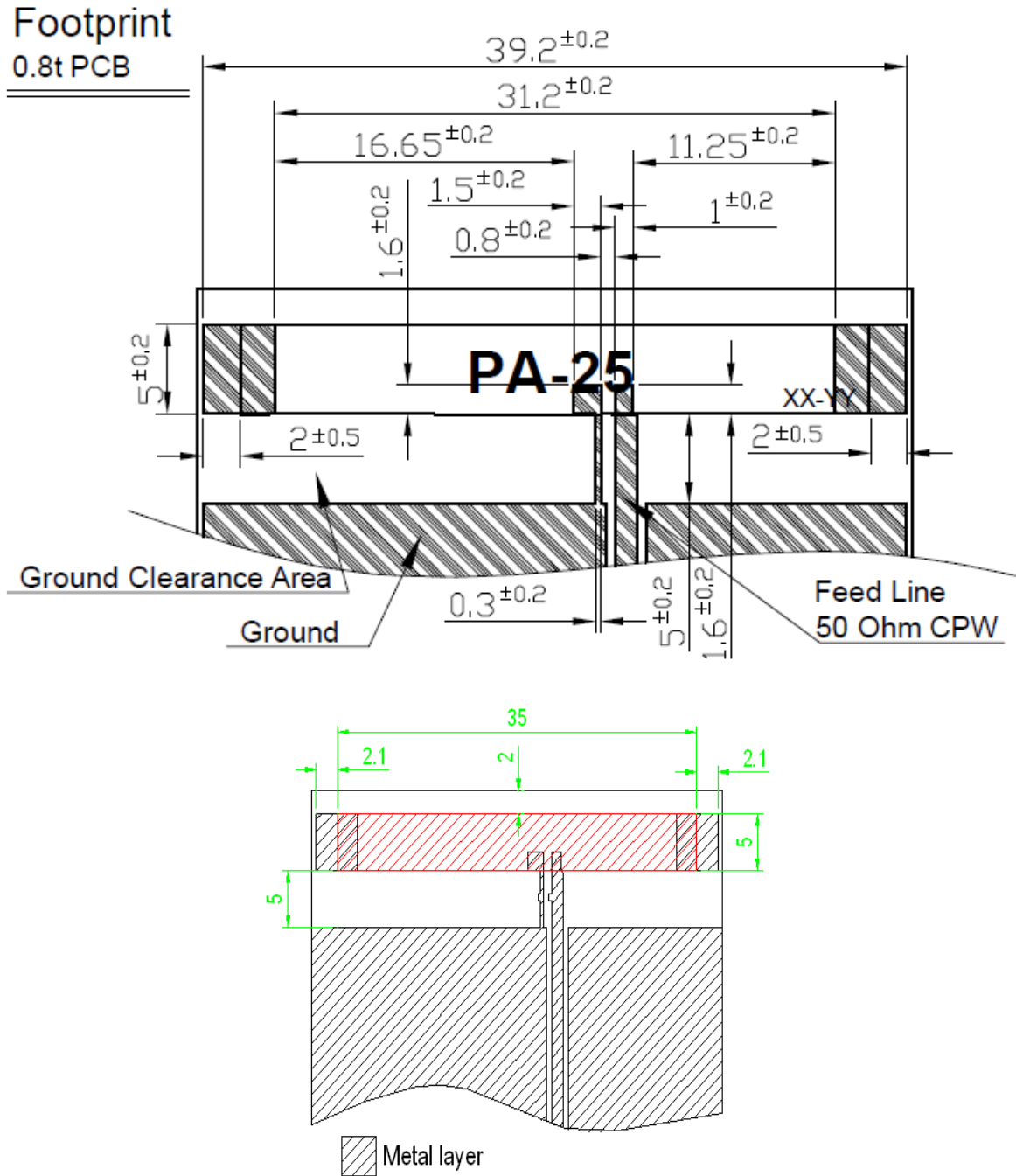

Figure 16. Baseline PCB Layout.

The size of the ground plane for the complete evaluation board is 95x40 mm (maximum performance). The size of the entire board including the antenna area free of ground plane is 107x40 mm. The area occupied by the antenna is 40x12 mm.

The next figure shows the antenna position on the layout.



The height of the antenna is 6 mm

Figure 17. Antenna location.

The size of the lumped components inductor is 0402. The layout has the area to allocate the inductor with a solder land of 0.6x0.5 mm for each pad, but can be changed as needed.

The antenna is mounted on evaluation board as in the next figures:



Figure 18. Antenna location on EVB (front view)..

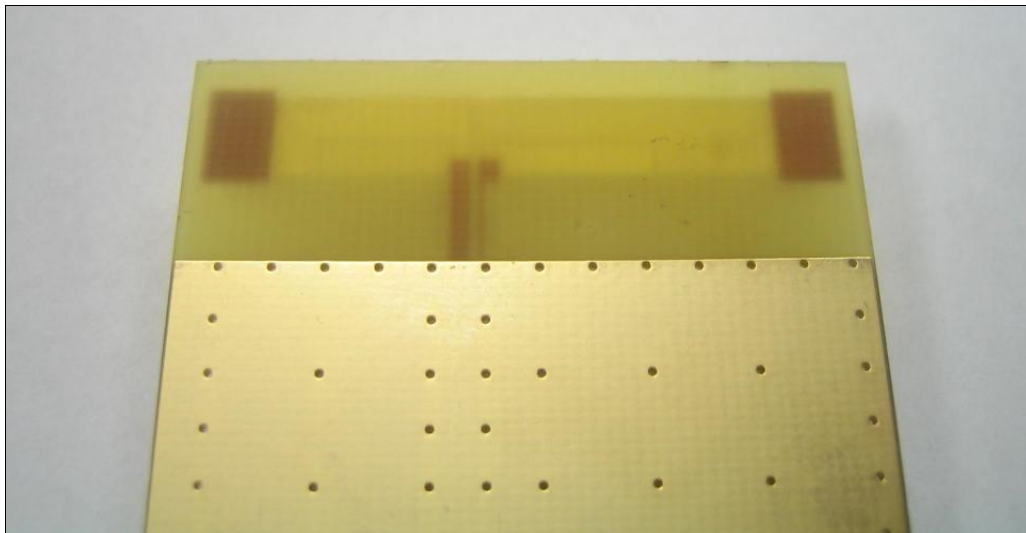

Figure 19. Antenna location on EVB (back view).

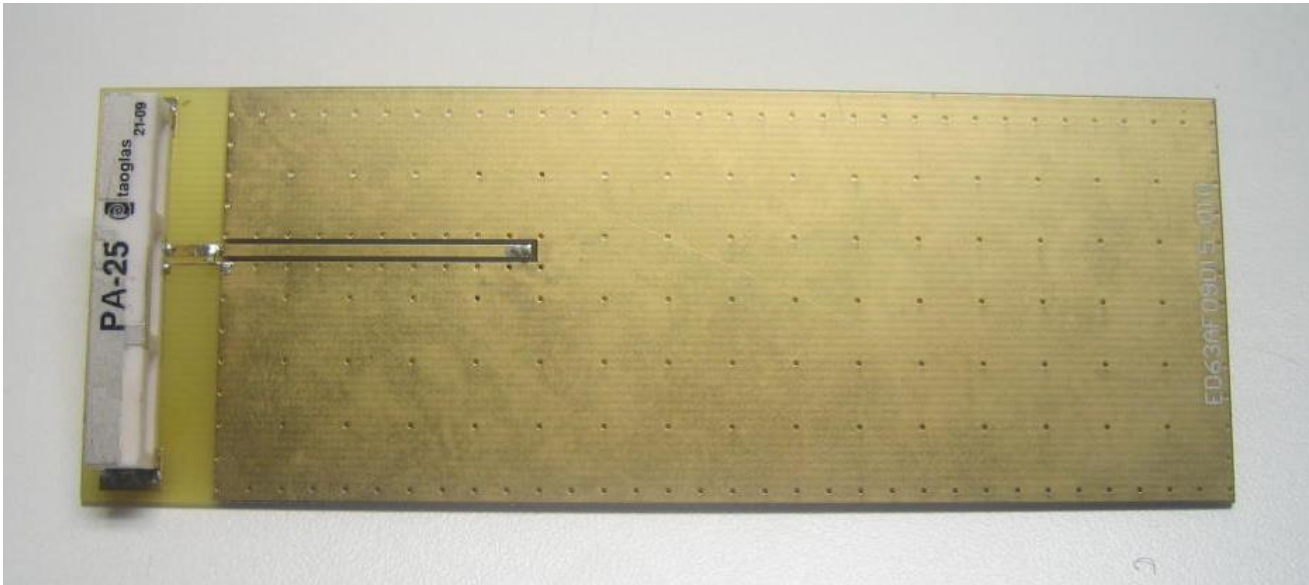

Figure 20. Antenna mounted on EVB.

To avoid movements of the antenna in the SMD process, we highly recommend following the next solder mask and solder pad areas.

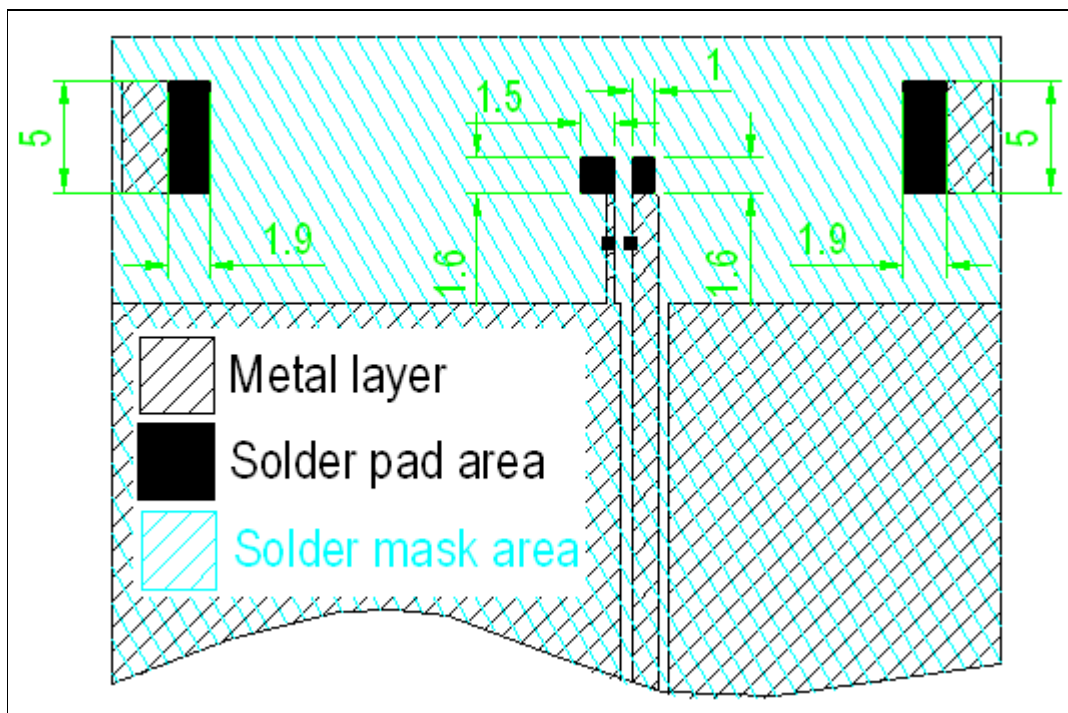

Figure 21. Solder pad and mask areas.

The next figure 22 shows the antenna dimensions.

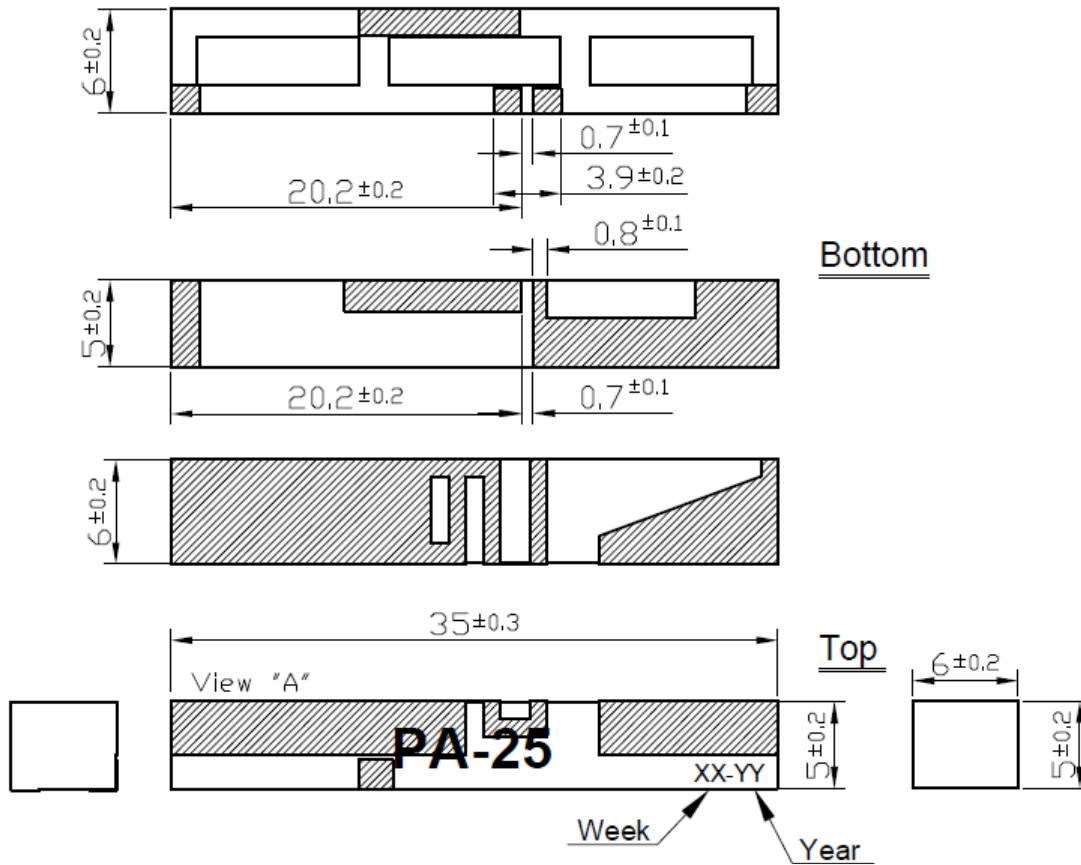

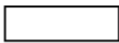

Figure 22. Solder pad and mask areas.

Silver 
 Ground Clearance Area 

16. MAJOR NO-NO'S

Under no circumstances must ground plane be placed beside the antenna, nor components, metal screws, or metal structures even if they are not grounded, these metal structures behave like they are grounded. No metal components or ground plane must be placed beyond the edge of the ground plane, above or below the PCB. The edge of the ground plane must be cut in flat shape along that side, as in the green line in the next figure.

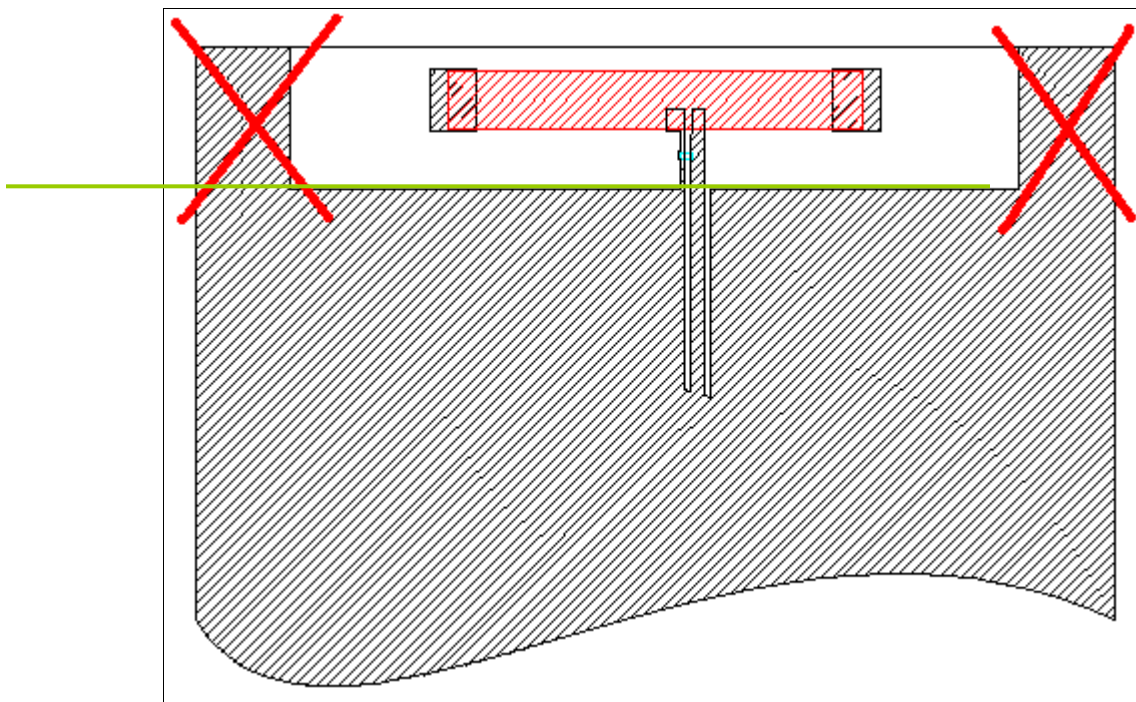

Figure 23. Solder pad and mask areas.

Do not place metal components, ground plane, daughter boards, LCD or other metal structure near the antenna, on the sides, above, or below on the other side of the board. All these structures must stop at the edge of the ground plane where the green line is drawn in the above figure.

If a thicker component is placed near the end of the ground plane edge, it is at better to have a larger clearance of more than 5 mm, such as an LCD panel, high metal components, etc.

We strictly recommend allocating the antenna in one of the shorter sides for rectangular boards.