

PCN – Process Change Notification

Change:	SGGP.18.4.A.02
Date:	2016/08/22
Author	Bonnie Chen

Affected Products

Model#	Part Number	Changes
SGGP18.4 Patch Antenna	SGGP.18.4.A.02	Amend Package

Type of Change

- Hardware Modification
 Production Process Advance
 Others – Packaging Rules Changing
-

Description of Change

1. Amend Carton Dimension from 370x360x275mm to 370x360x305mm, to solve the carton height isn't enough for packaging.

Schedule

2016, August, Taoglas will input this new packaging rules into production.

Forecast Estimated Transition Date

Aug/2016

Illustration of Change

Old packaging rules

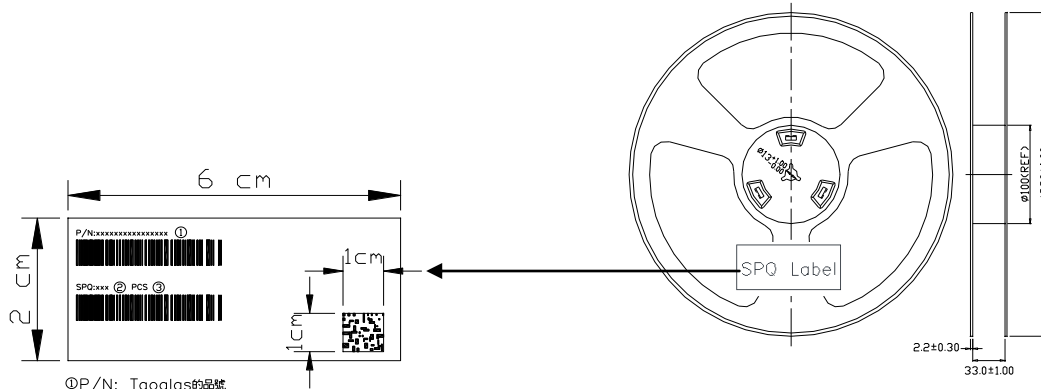

①P/N: Taoglas的品號
②SPQ QTY: SPQ的數量
③Unit:每一數量的單位

Vacuum packaging
Pieces/tape:200pcs

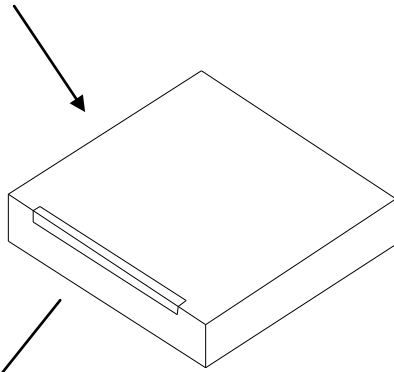

Carton-Inside
(350*340*67mm)

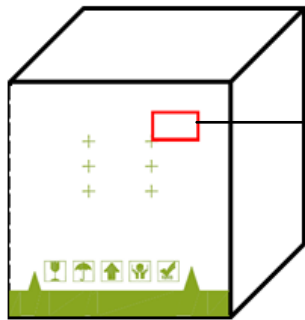

800 Units/Carton
370*360*275mm

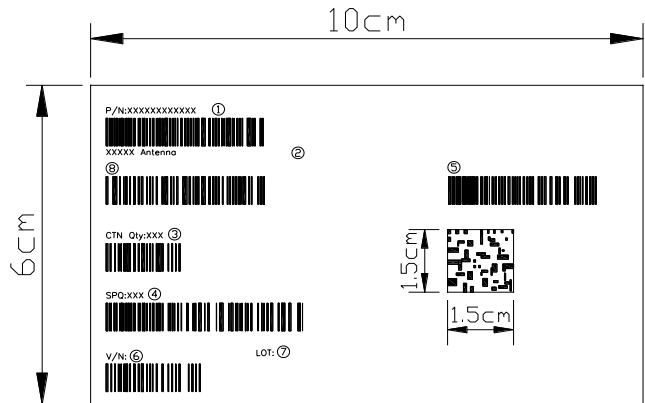

1.P/N: Taoglas的品號
2.Description: Taoglas的品名
3.CTN QTY: 外箱數量
4.SPQ QTY: SPQ數量
5.Purchase No.: Taoglas採購單號
6.V/N: 廠商品號
7. 廠商批號
8.Batch No.: Taoglas的批號, 請廠商依下列批號
原則建立每批進廠批號, 廠商碼將另行通知。

I 03 001 0001
T: 正品
P: 備品
03: 年
001: 廠商碼
0001: 流水碼

New packaging rules

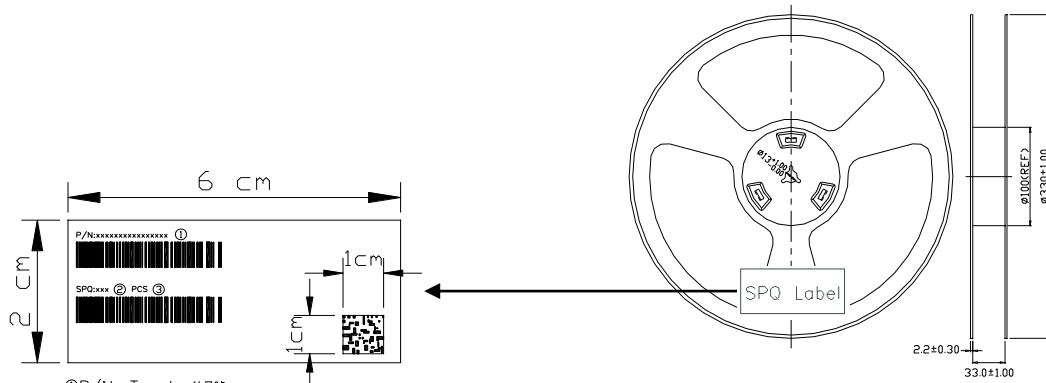

①P/N: Taoglas的品號
 ②SPQ QTY: SPQ的數量
 ③Unit:每一數量的單位

Vacuum packaging
 Pieces/tape:200pcs

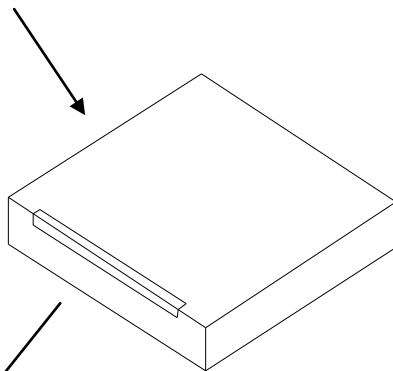

Carton-Inside
 (350*340*67mm)

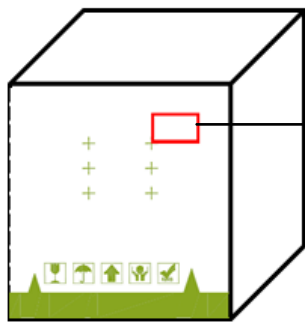

800 Units/Carton
 370*360*305mm

Amend Carton Dimension.

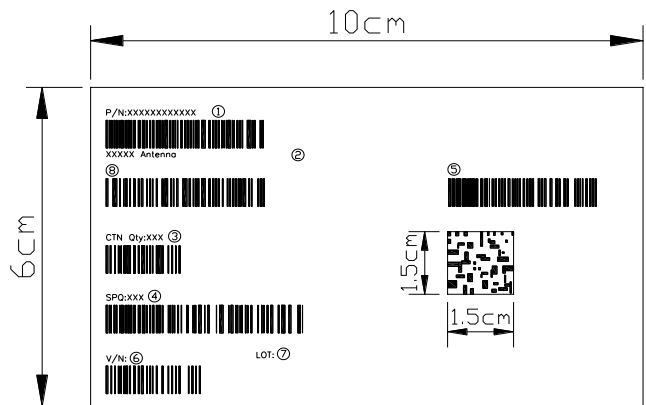

1.P/N: Taoglas的品號
 2.Description: Taoglas的品名
 3.CTN QTY:外箱數量 T:正品 03:年 001:廠商碼 0001:流水碼
 4.SPQ QTY: SPQ數量 P:備品
 5.Purchase No.: Taoglas採購單號
 6.V/N:廠商品號
 7.廠商批號
 8.Batch No.: Taoglas的批號,請廠商依下列批號
 原則建立每批進廠批號,廠商碼將另行通知。