

PCN – Process Change Notification

Change:	FW.91.TNC.M
Date:	2016/12/16
Author	Haley Tsai

Affected Products

Model#	Part Number	Changes
FW.91 Penta-band Cellular Flexible Whip Antenna TNC(M)	FW.91.TNC.M	Amend Package.

Type of Change

- Hardware Modification
- Production Process Advance
- Others –Amend package.

Description of Change

1. Amend Package rules to meet Taoglas Bar code system and standard package quantity rules.

Schedule

2016, December, Taoglas will input this new rules into production.

Forecast Estimated Transition Date

December/2016

Illustration of Change

Old Package

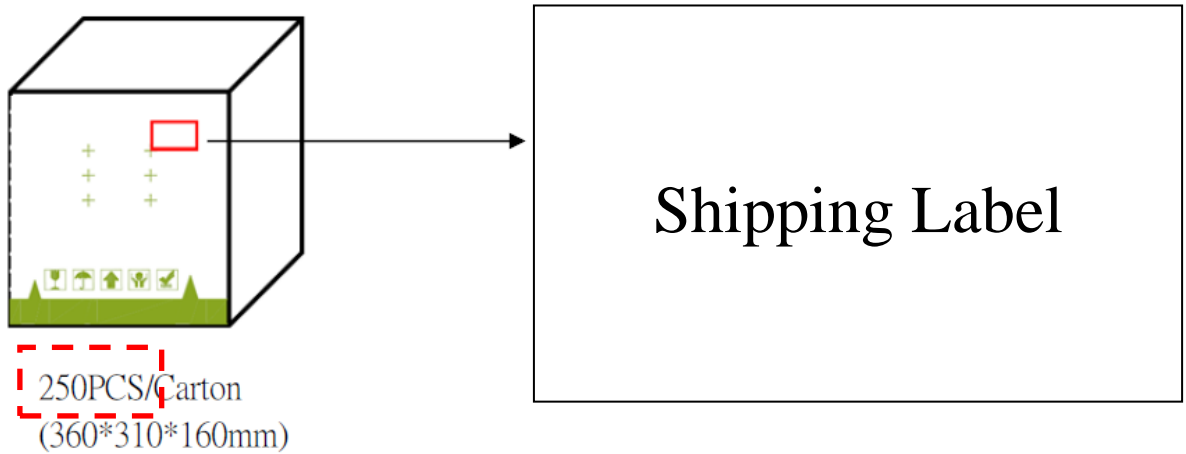
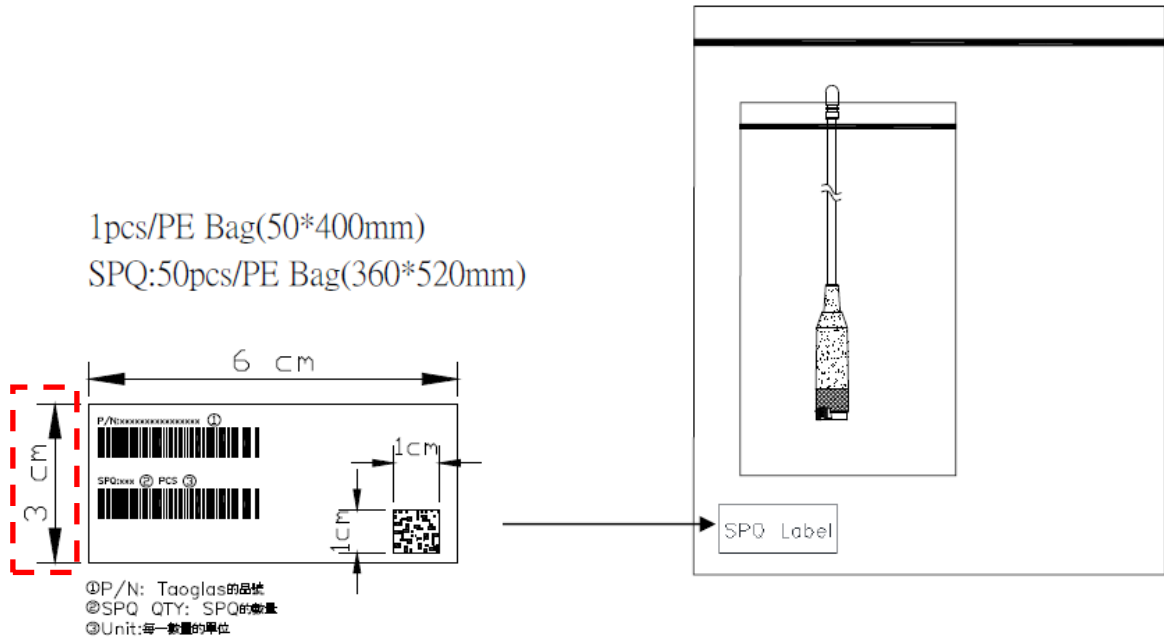

Illustration of Change

New and Package

