

PCN – Process Change Notification

Change:	G21.B.301111
Date:	2017/02/20
Author	Haley Tsai

Affected Products

Model#	Part Number	Changes
Hercules Penta-band Screw-Mount Cellular Antenna with 3M RG174 SMA(M) Straight GEN II	G21.B.301111	Packaging rules changing.

Type of Change

- Hardware Modification
 Production Process Advance
 Others – Packaging Rules Changing
-

Description of Change

Due to Taoglas will input Barcode tracking process, we need to amend the packaging rules and labelling on barcode labels on standard packaging quantity bag and cartons.

Schedule

2017, February, Taoglas will input this new packaging rules into production.

Forecast Estimated Transition Date

Feb/2017

Illustration of Change

Old packaging rule

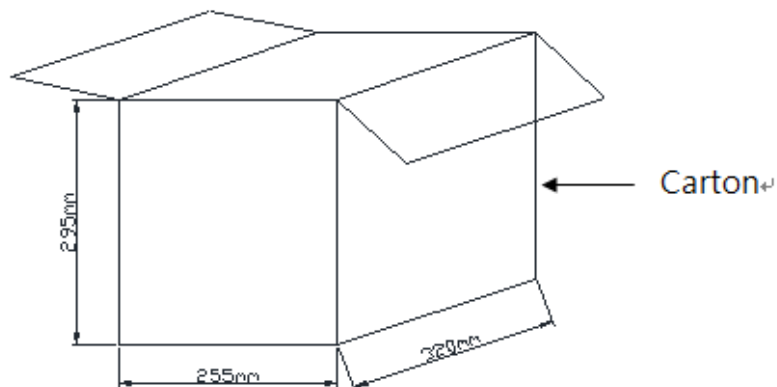
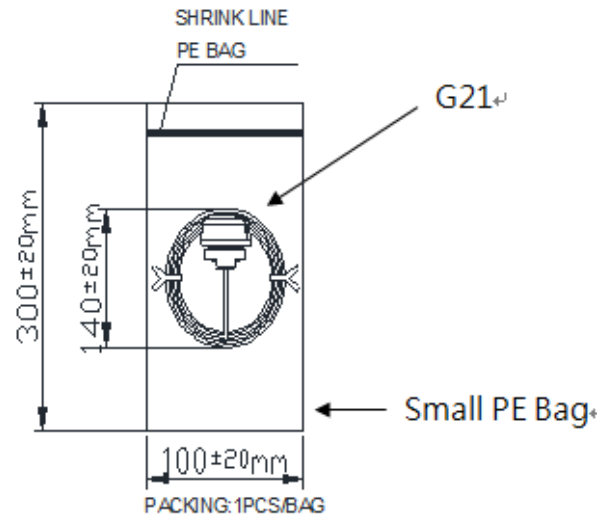

New packaging rule

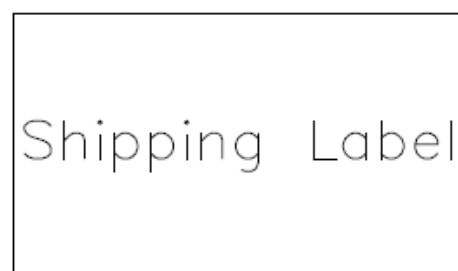
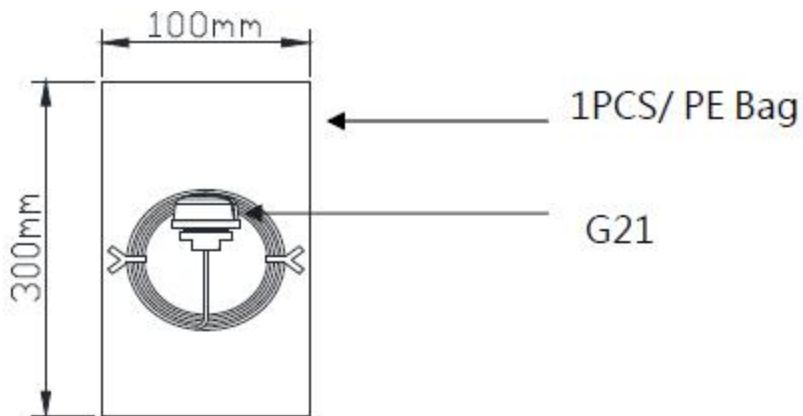

60PCS/Carton

(320*250*290mm)