

PCN – Process Change Notification

Change:	IS.05.B.301111
Date:	2017/08/18
Author	Bonnie Chen

Affected Products

Model#	Part Number	Changes
915MHz Hercules Screwmount Antenna with 0.3M RG-174 SMA(M)	IS.05.B.301111	1. Amend Package Rule.

Type of Change

- Hardware Modification
 Production Process Advance
 Others –Amend Package Rule.
-

Description of Change

1. Amend Package Rule.

Schedule

2017, August, Taoglas will provide new package rule into production.

Forecast Estimated Transition Date

Aug/2017

Illustration of Change

Old Package

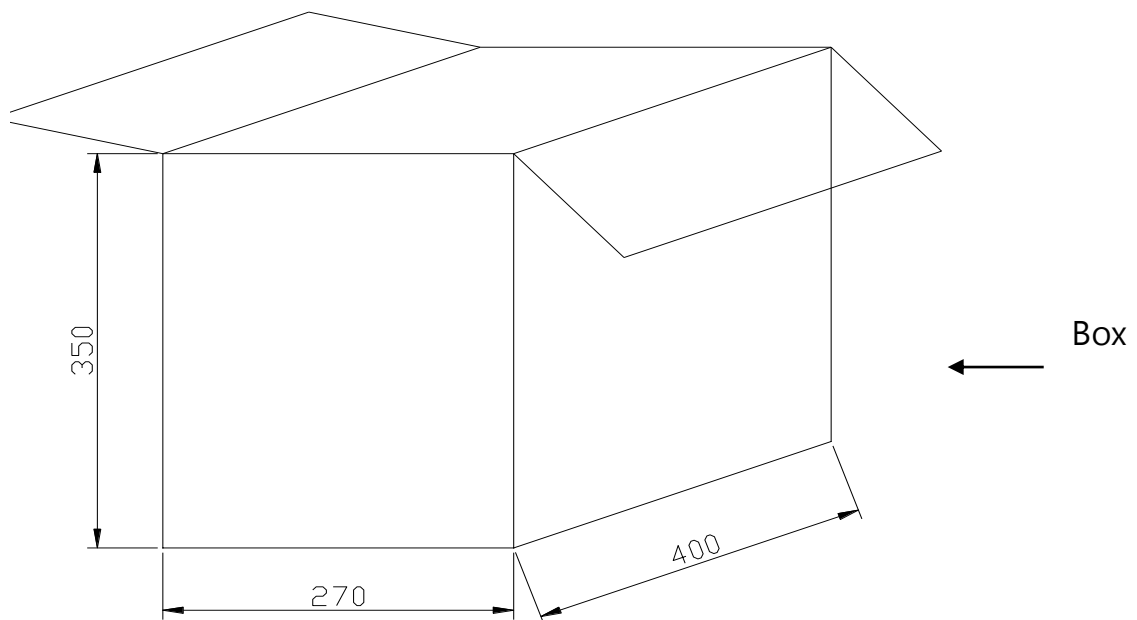
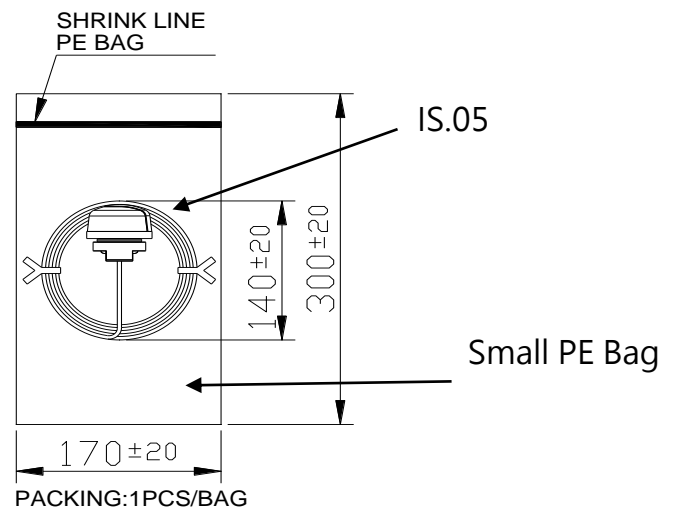

New Package

