



# TAOGLAS®



# Datasheet

## Magma Series

**Part No:**  
AA.185.301111

### Description

Magnetic/Adhesive Mount, Low Profile, Single Stage LNA GNSS Antenna  
With 3m RG-174 and SMA(M)

### Features:

- GPS-GLONASS Antenna - Covering Bands L1 / B1I / G1
- Compact, Low-profile IP67 Rated Enclosure
- Magnetic or Adhesive Mounting Options
- Adhesive Mounting Pad Included
- Dimensions: 35.7mm x 35.7mm x 15 mm
- Cable: 3m of RG174
- Connector: SMA(M)
- RoHS & Reach Compliant

<b>1.</b>	<b>Introduction</b>	<b>3</b>
<b>2.</b>	<b>Specification</b>	<b>4</b>
<b>3.</b>	<b>Mechanical Drawing</b>	<b>7</b>
<b>4.</b>	<b>Packaging</b>	<b>8</b>
<b>5.</b>	<b>Antenna Characteristics</b>	<b>9</b>
<b>6.</b>	<b>Radiation Patterns</b>	<b>14</b>
<b>7.</b>	<b>LNA Characteristics</b>	<b>18</b>
<hr/>		
	Changelog	27

Taoglas makes no warranties based on the accuracy or completeness of the contents of this document and reserves the right to make changes to specifications and product descriptions at any time without notice. Taoglas reserves all rights to this document and the information contained herein. Reproduction, use or disclosure to third parties without express permission is strictly prohibited.

Ireland & USA  
ISO 9001:2015  
Certified



Taiwan  
ISO 9001:2015  
Certified



# 1. Introduction



The compact Magma AA.185 is an adhesive/magnetic mount antenna is ideal for covert installations where durability and small size is paramount. This low-profile antenna is tuned for stable operation over GPS, GLONASS, Galileo and BeiDou L1/E1/B1 frequency bands and is used in a wide range of applications where GNSS services are required. At only 35mm square and 15mm in height, it is one of the most compact high accuracy antenna in the market for L1 operation. The robust ASA IP67 rated enclosure allows the Magma X to be used either internally or externally in challenging environments.

Typical Applications include:

- Advanced Telematics, Navigation and Fleet Management
- M2M applications, Construction and Agriculture
- High accuracy timing and positioning systems

The use of a dual-pin patch design improves the axial ratio at the centre of the band, delivering right hand circular polarization. The helps increase location accuracy and improve the speed of time to first fix for GNSS systems used in challenging environments. A front-end SAW reduces out-of-band interference from any nearby wireless transmitters, helping prevent LNA compression and burnout.

3m of RG-174 cable is used as standard with and an SMA(M) connector, both are customizable upon request. An alternate version with a dual stage LNA design is also available, see the [AA.186](#). For further information, contact your regional Taoglas customer support team.

## 2. Specification

GNSS Frequency Bands					
GPS	L1 1575.42 MHz	L2 1227.6 MHz	L5 1176.45 MHz		
	■	□	□		
GLONASS	G1 1602 MHz	G2 1248 MHz	G3 1207 MHz		
	■	□	□		
Galileo	E1 1575.24 MHz	E5a 1176.45 MHz	E5b 1201.5 MHz	E6 1278.75 MHz	
	■	□	□	□	
BeiDou	B1C 1575.42 MHz	B1I 1561 MHz	B2a 1176.45 MHz	B2b 1207.14 MHz	B3 1268.52 MHz
	■	■	□	□	□
L-Band	L-Band 1542 MHz				
	□				
QZSS (Regional)	L1 1575.42 MHz	L2C 1227.6 MHz	L5 1176.45 MHz	L6 1278.75e6	
	■	□	□	□	
IRNSS (Regional)	L5 1176.45 MHz				
	□				
SBAS	L1/E1/B1 1575.42 MHz	L5/B2a/E5a 1176.45 MHz	G1 1602 MHz	G2 1248 MHz	G3 1207 MHz
	■	□	■	□	□

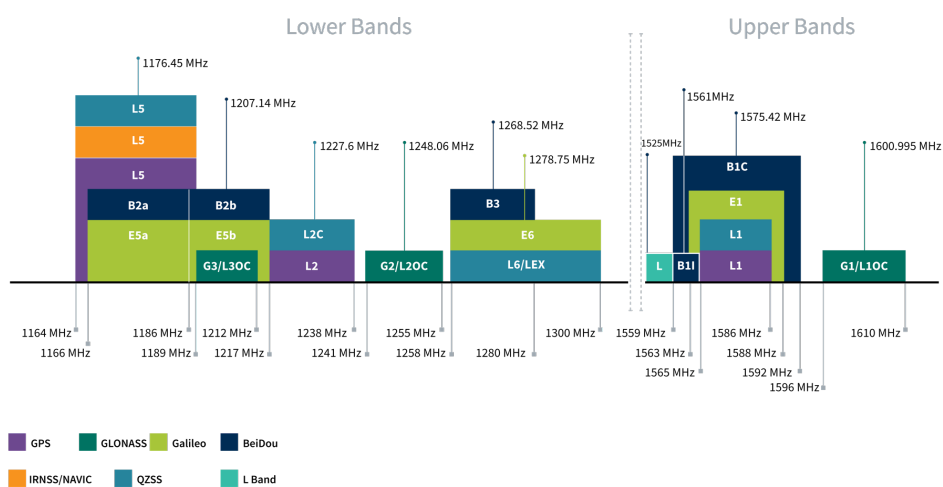

GNSS Bands and Constellations

GNSS Electrical				
Frequency (MHz)	Test Set-up	L1 [1575.42 MHz]	B11 [1561 MHz]	G1/L1OC [1600.995 MHz]
		1565-1586	1559-1565	1596-1610
VSWR (max.)	70x70mm Metal Ground Plane	2:1	2:1	2:1
Efficiency avg. for the freq. band	70x70mm Metal Ground Plane	62.04	53.71	55.51
Avg. Gain avg. for the freq. band	70x70mm Metal Ground Plane	-2.08	-2.70	-2.56
Peak Gain	70x70mm Metal Ground Plane	3.52	2.80	3.11
AR at Zenith avg. for the freq. band	70x70mm Metal Ground Plane	1.77	2.02	0.61
PCO_x (cm)		0.79	0.81	0.78
PCO_y (cm)		4.57	4.84	5.45
PCV (cm)		0.01	0.01	0.01
Polarization		RHCP		
Impedance		50 Ω		

LNA and Filter Electrical Properties			
Frequency (MHz)	1561	1575.42	1602
Gain(dB)	15.19	15.29	14.86
Noise Figure(dB)	2.14	1.86	2.14
Group Delay(ns)	19.66	15.19	18.59
Out Of Band Rejection	> 65dB @ <1GHz and 35dB @ 1.5~3GHz		
Input Voltage (VDC)	1.8~5.5		
Current Consumption(mA)	< 5		
IEC61000-4-2 (ESD protection)	± 30 kV air / ± 20kV contact discharge		

Mechanical	
Dimensions	35.7 x 35.7 x 15mm
Weight	72g
Material	ASA
Connector	SMA(M)
Cable	3m of RG174
Magnetic Horizontal Pull Force	0.52 Kgf

Environmental	
Waterproof Rating	IP67
Operation Temperature	-40°C to 85°C
Storage Temperature	-40°C to 85°C
Relative Humidity	Non-condensing 65°C 95% RH
RoHS & REACH Compliant	Yes

### 3. Mechanical Drawing

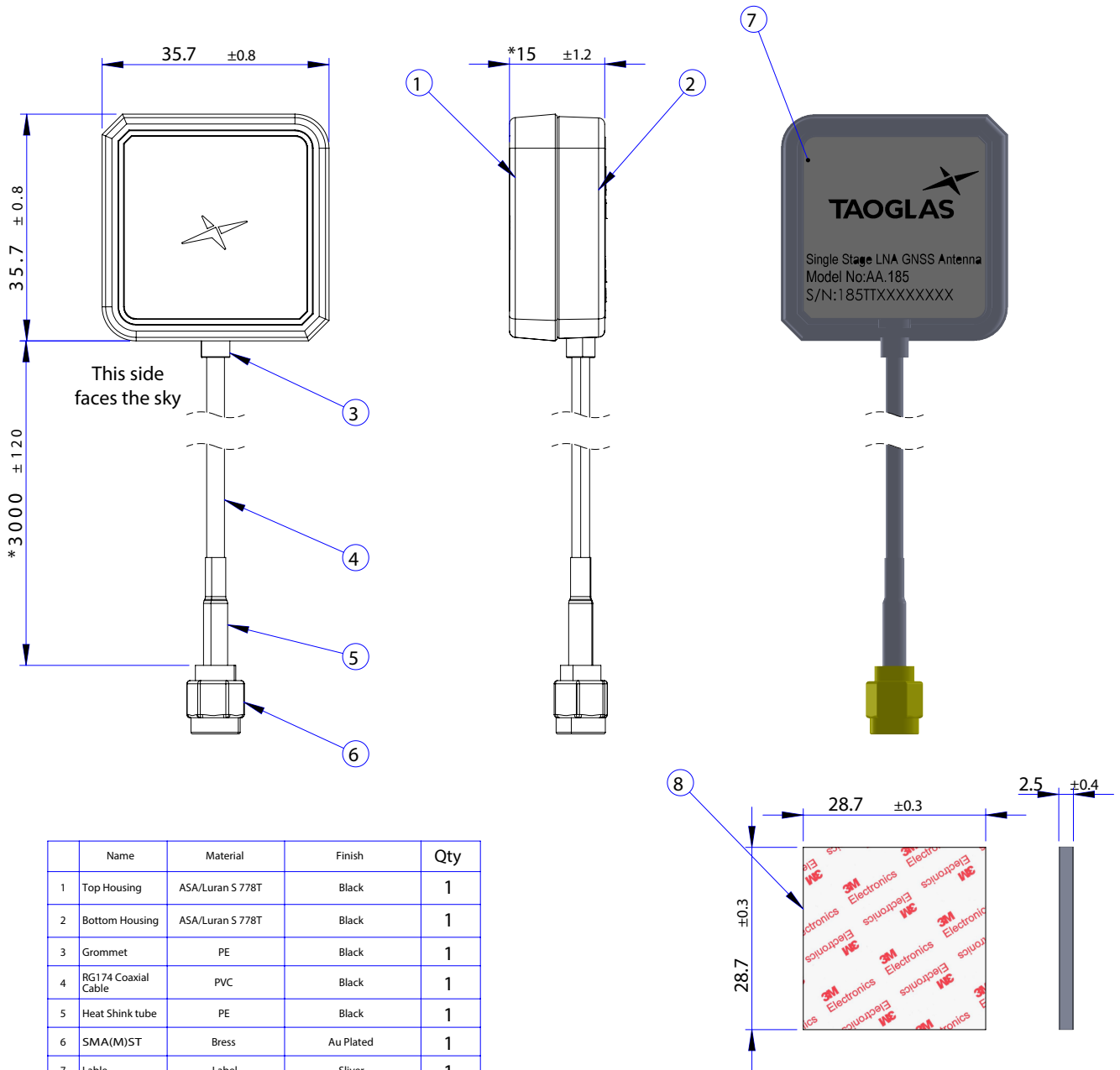

	Name	Material	Finish	Qty
1	Top Housing	ASA/Luran S 778T	Black	1
2	Bottom Housing	ASA/Luran S 778T	Black	1
3	Grommet	PE	Black	1
4	RG174 Coaxial Cable	PVC	Black	1
5	Heat Shink tube	PE	Black	1
6	SMA(M)ST	Bress	Au Plated	1
7	Lable	Label	Sliver	1
8	Foam	CR4305+3M adhesive	Black Foam w/ white liner	1

## 4. Packaging

1pcs AA.185.301111 per Small PE Bag  
 Dimensions – 130 x 230mm  
 Weight - 72g

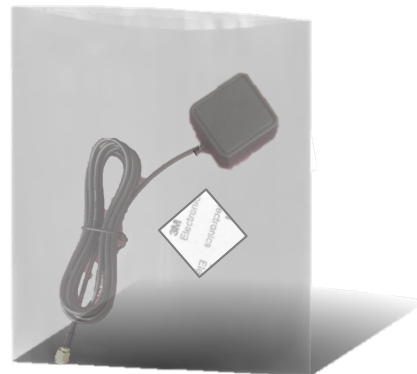

10pcs AA.185.301111 per Large PE Bag  
 Dimensions: 220 x 460mm  
 Weight – 0.73Kg

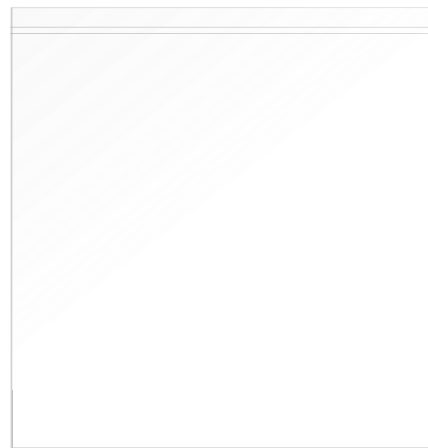

100pcs AA.185.301111 per carton  
 Dimensions – 370 x 370 x 300mm  
 Weight – 8.1Kg

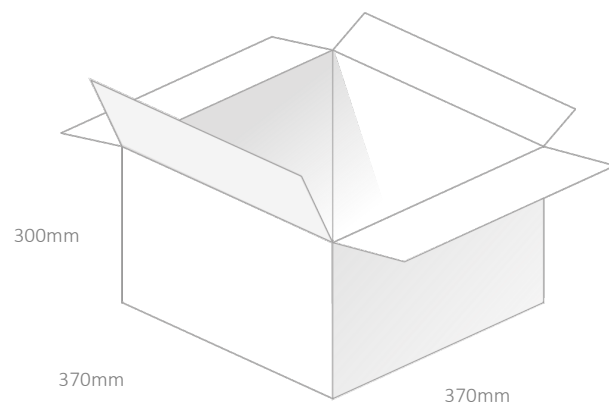



## 5. Antenna Characteristics

### 5.1 Test Setup

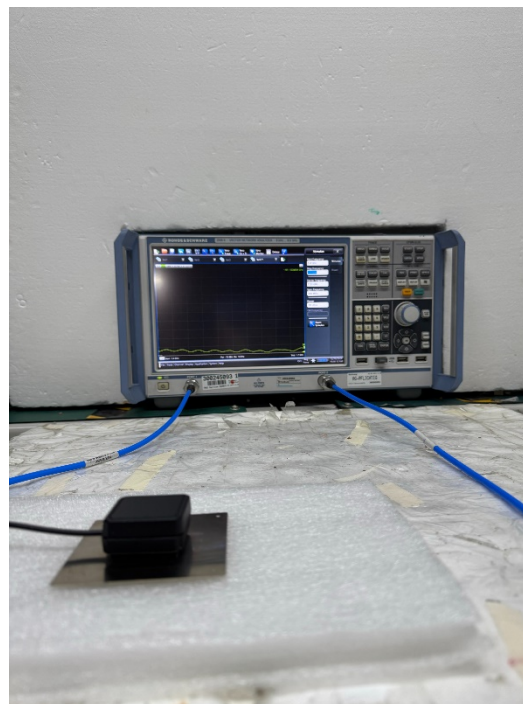
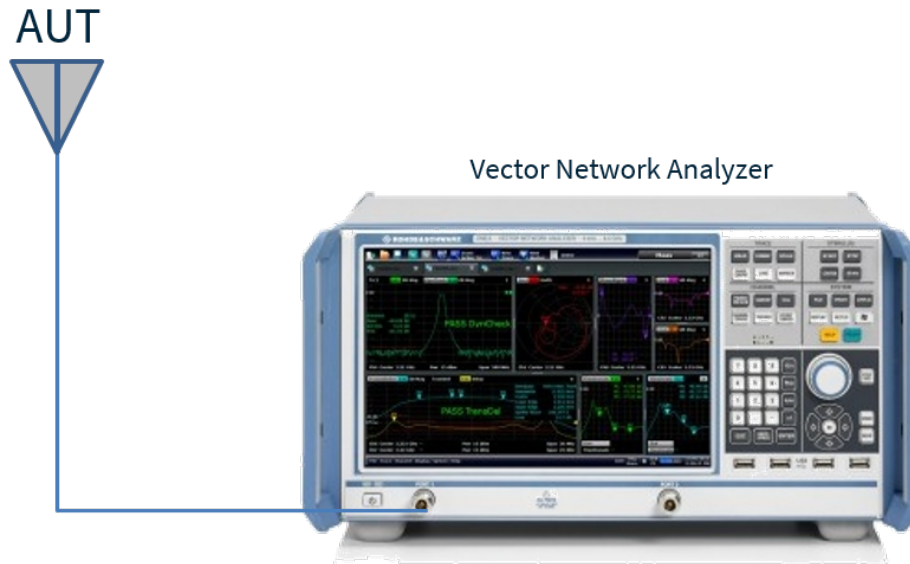

70x70mm Metal Ground Plane  
VNA Test Setup

## 5.2 Return Loss

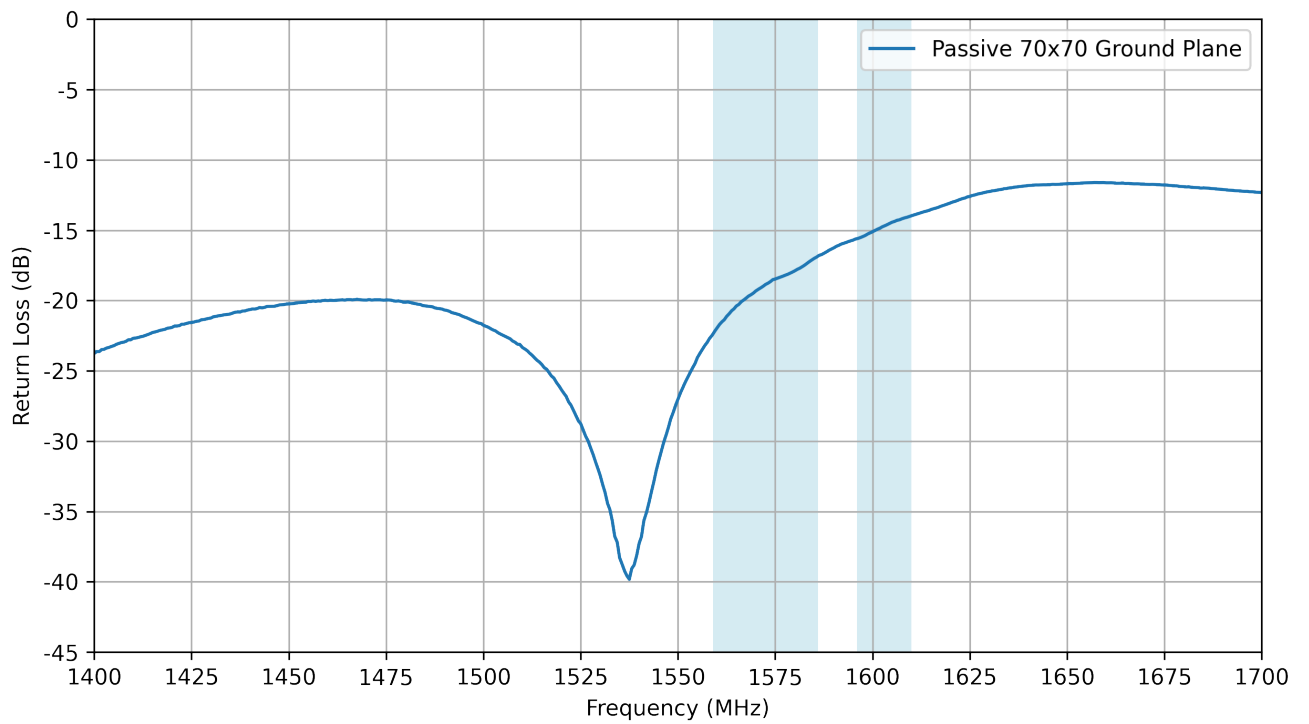

## 5.3 VSWR

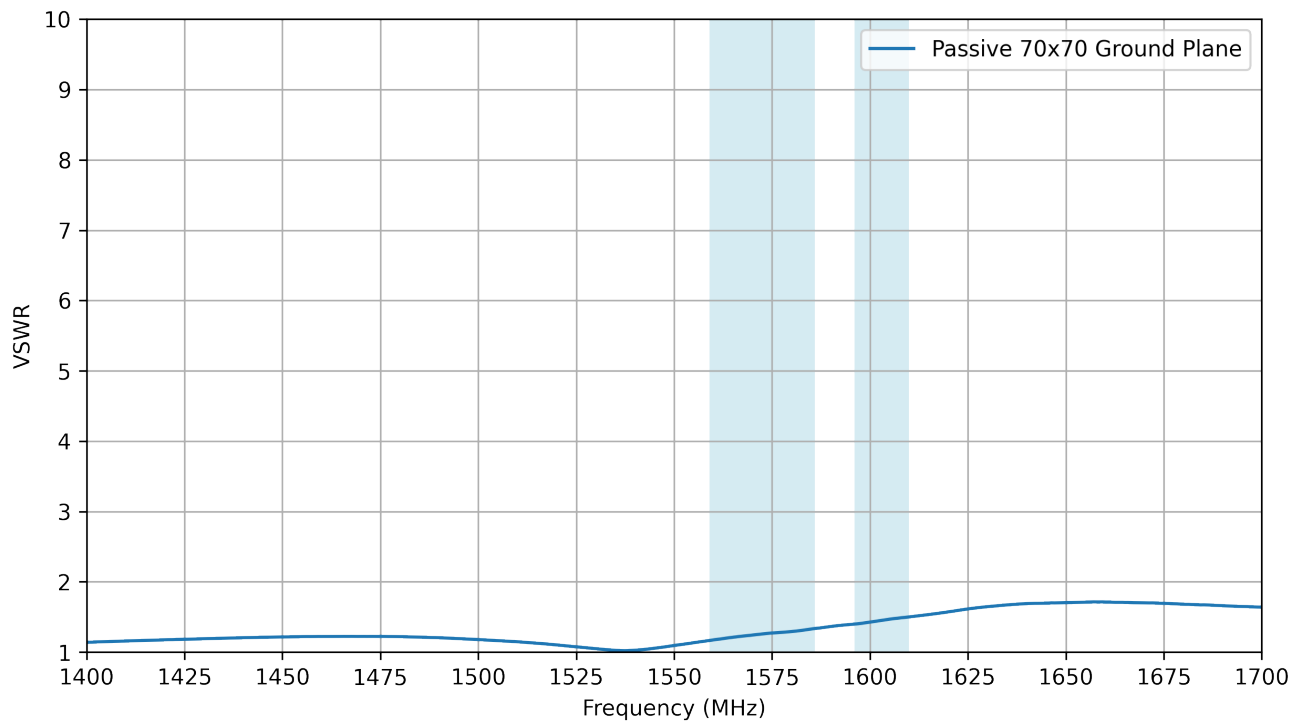

## 5.4 Efficiency

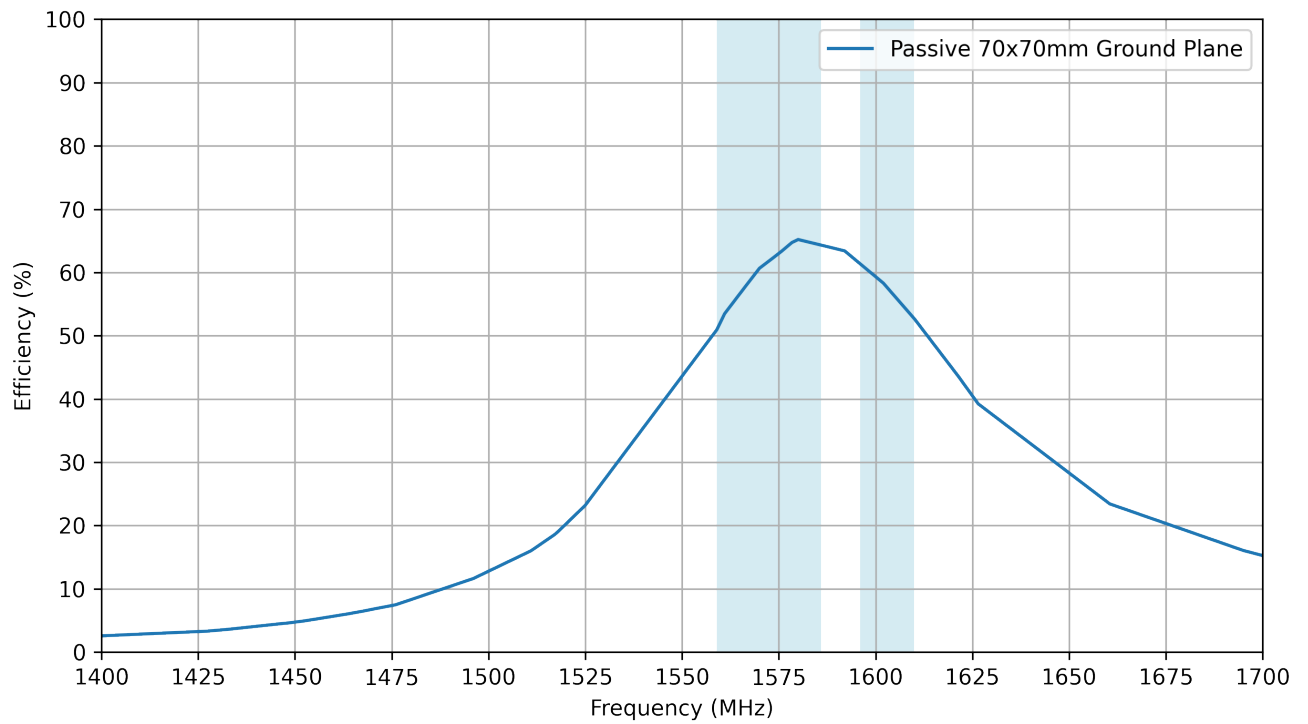

## 5.5 Average Gain

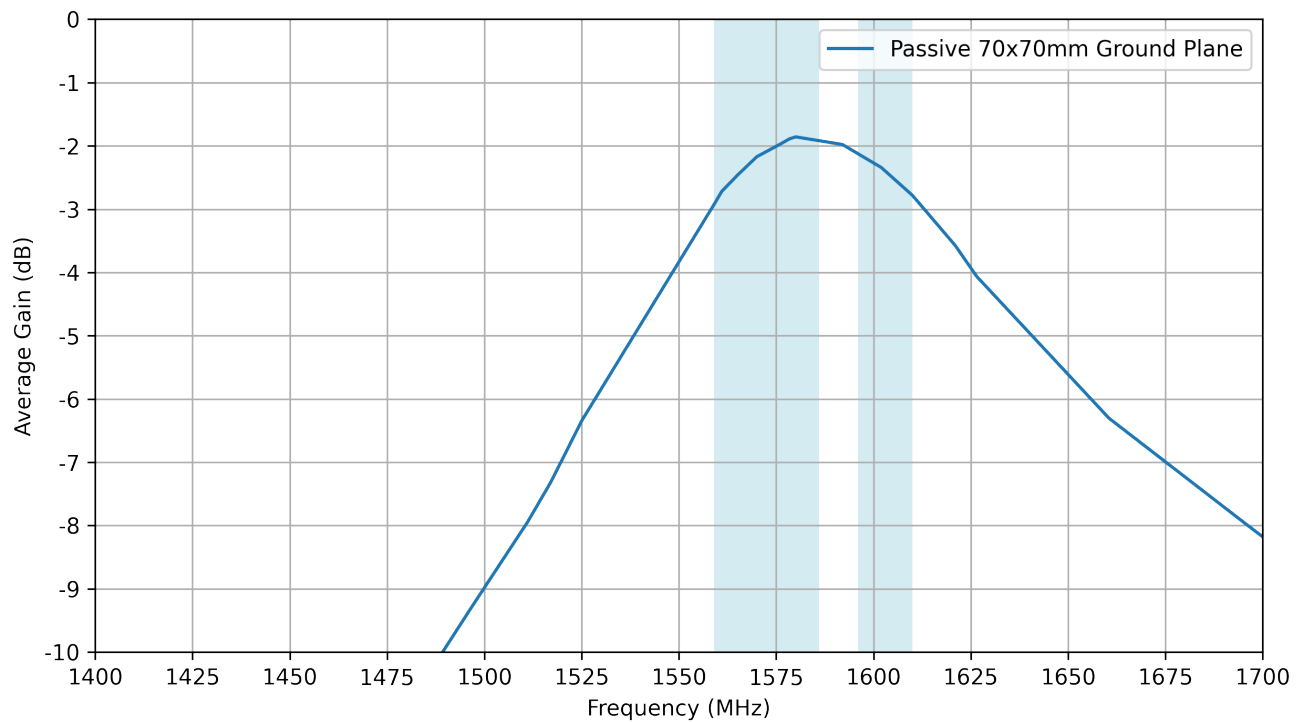

## 5.6 Peak Gain

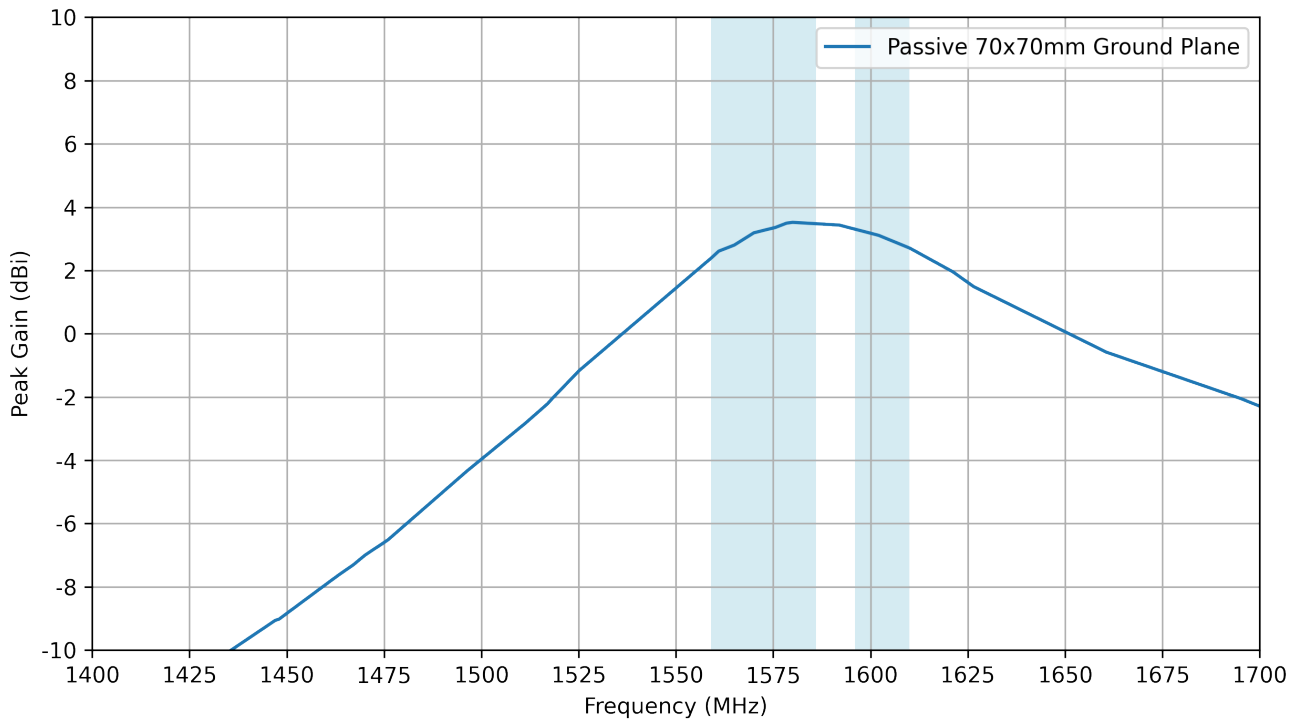

## 5.7 Axial Ratio

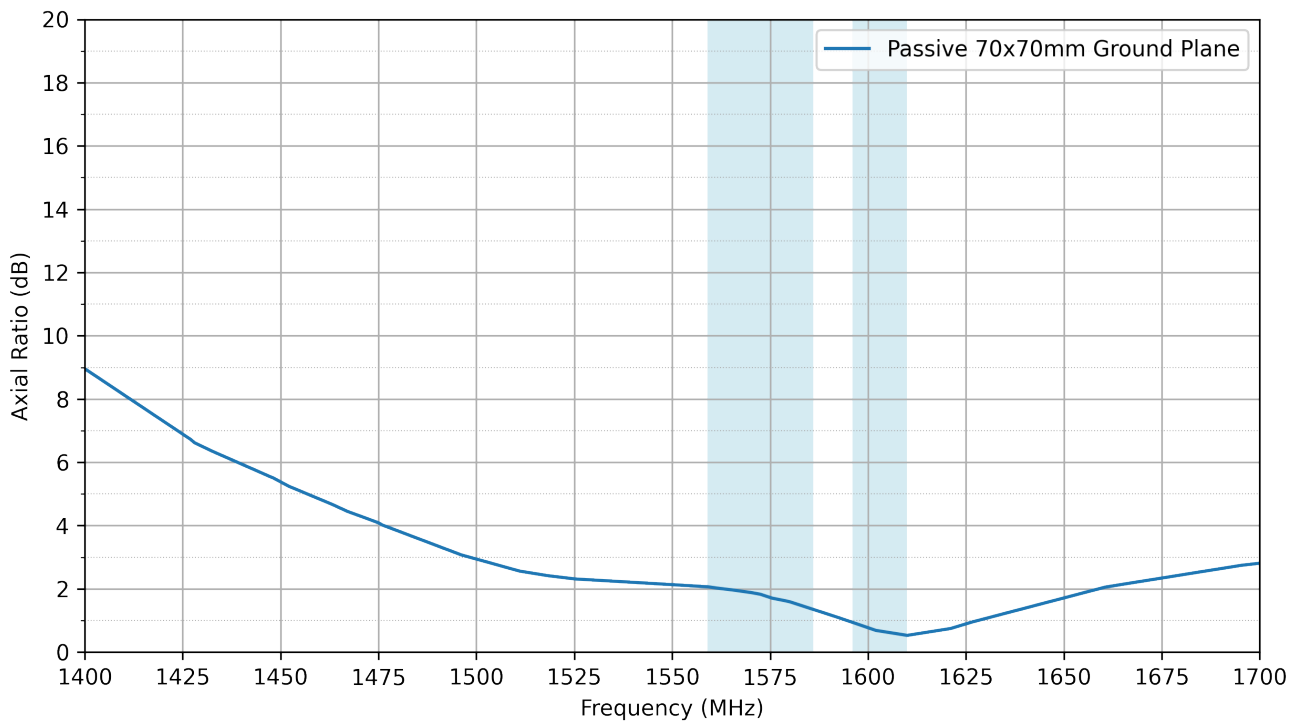

## 5.8 PCO

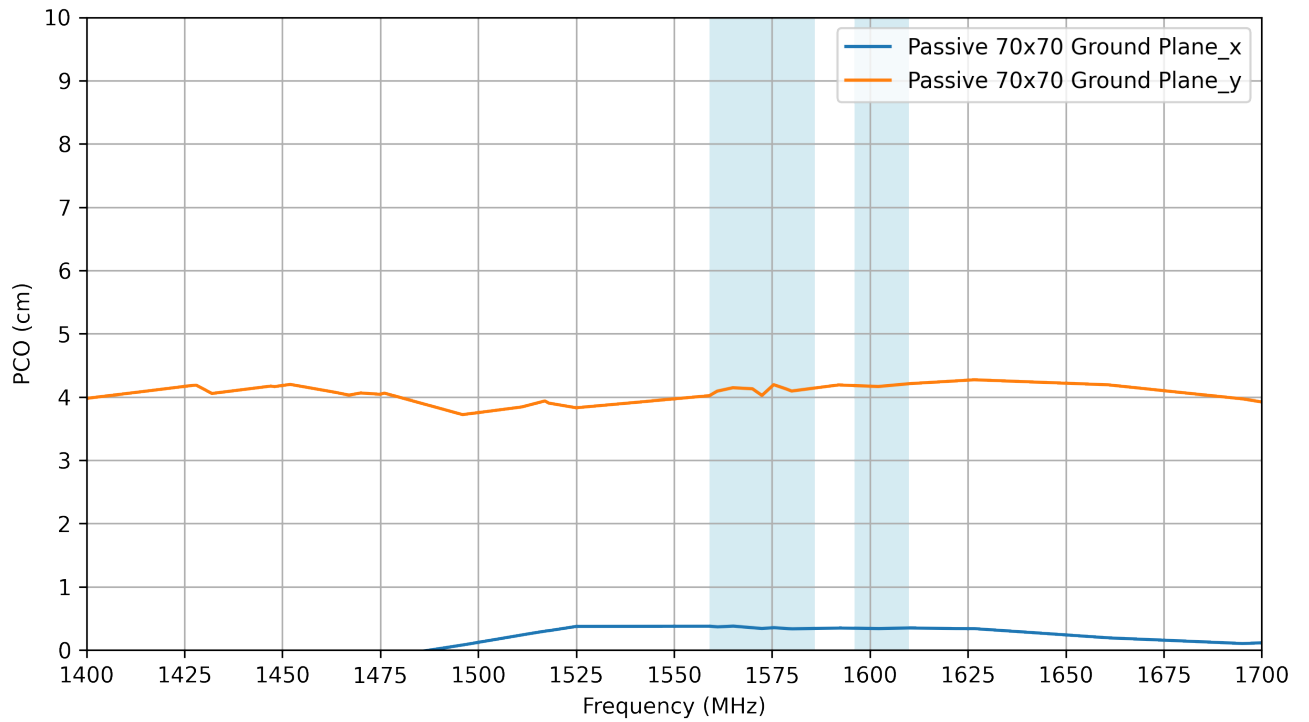

## 5.9 PCV

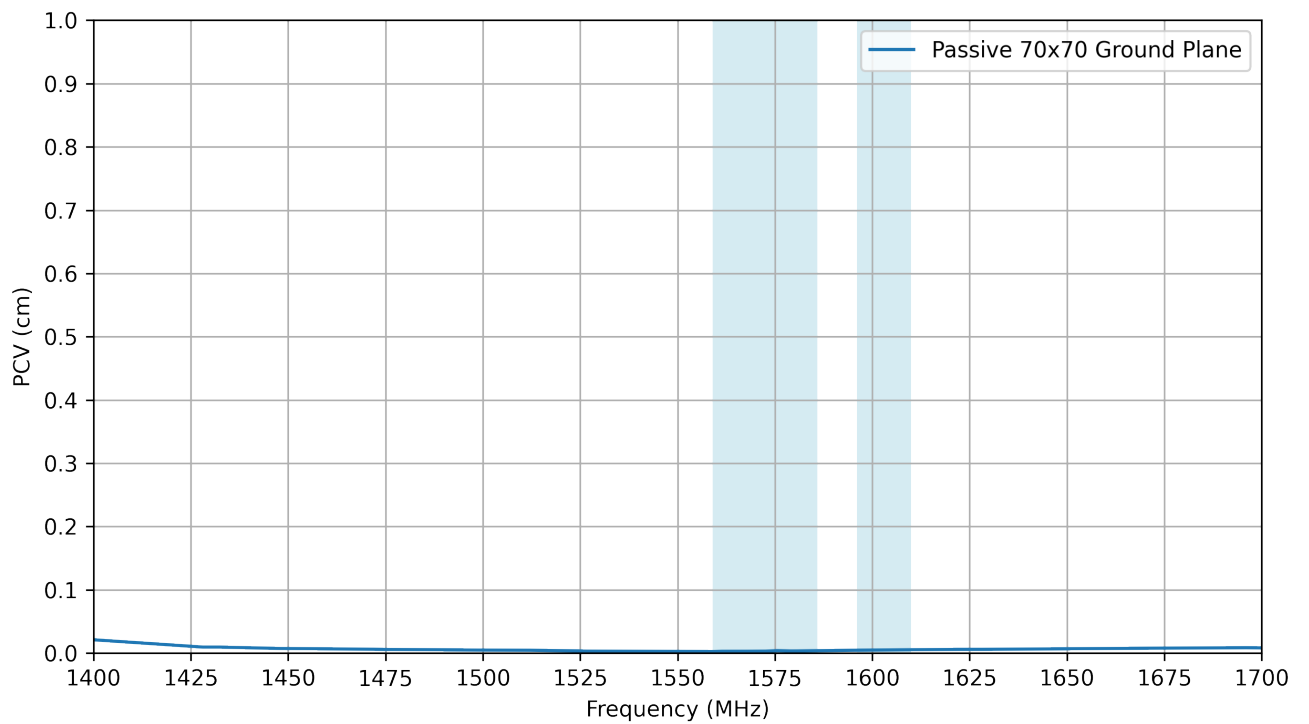

## 6. Radiation Patterns

### 6.1 Test Setup

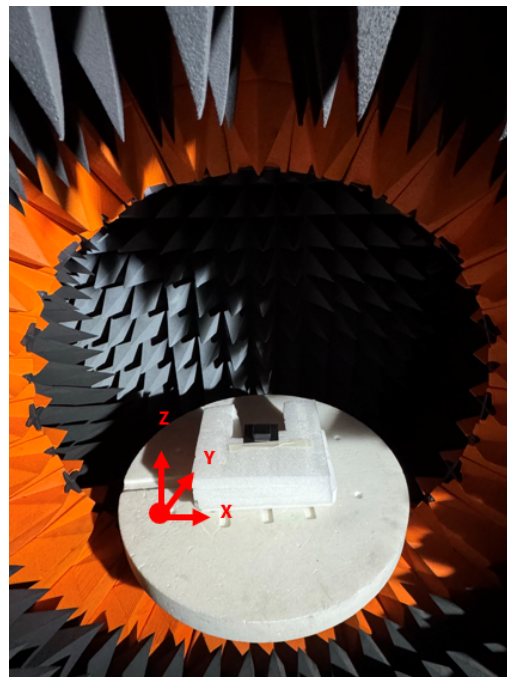
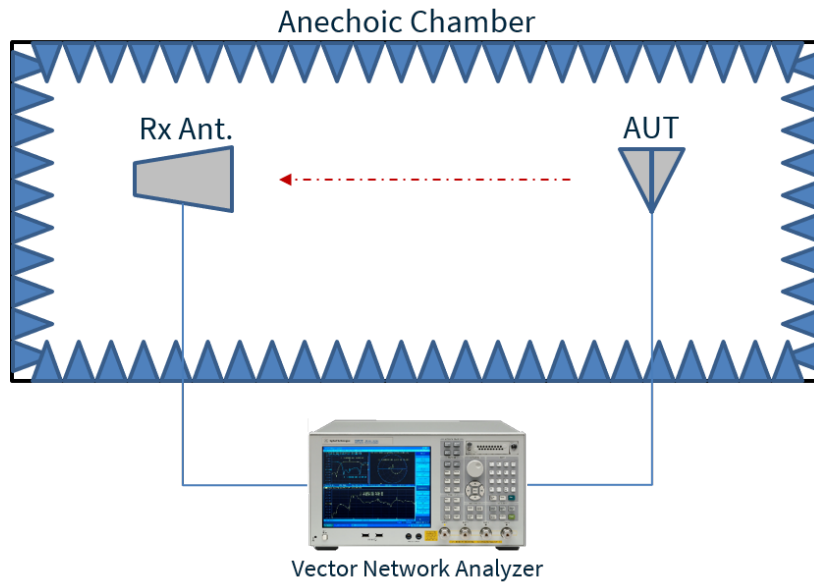

70x70mm Metal Ground Plane Chamber Test Setup

6.2 Passive 70x70mm Ground Plane Patterns at 1561 MHz

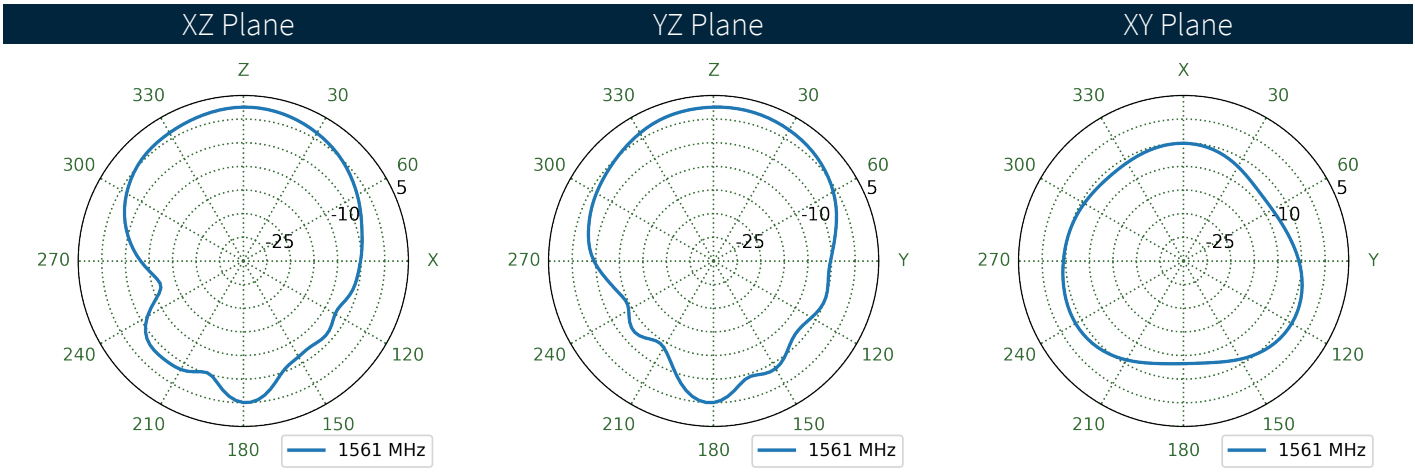
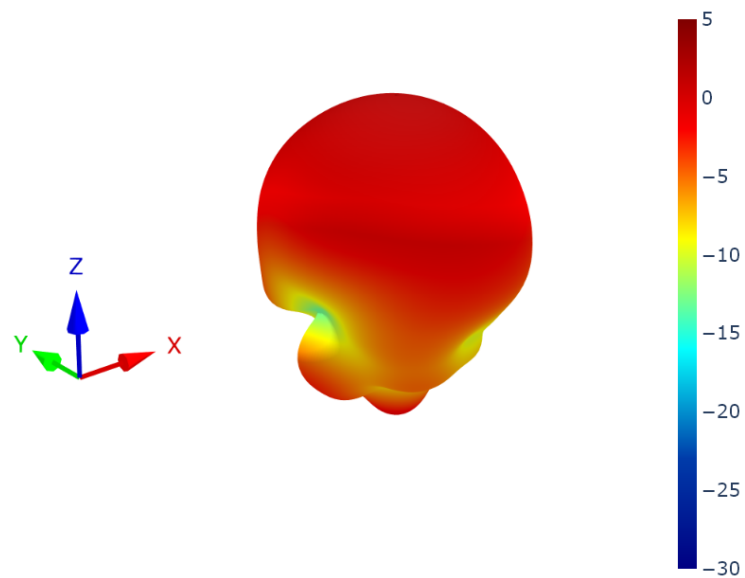

6.3 Passive 70x70mm Ground Plane Patterns at 1575 MHz

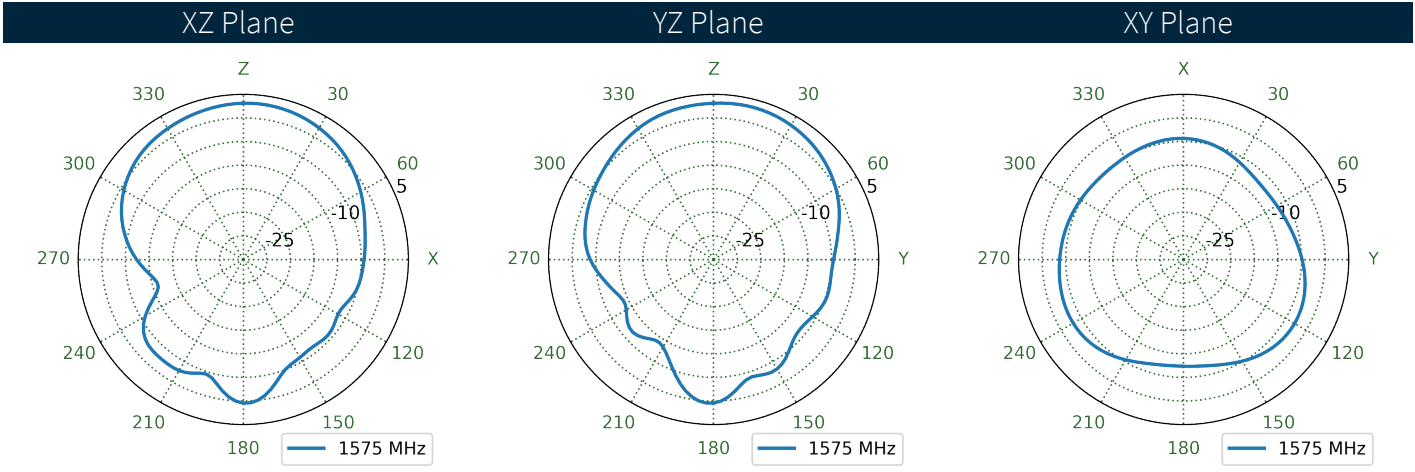
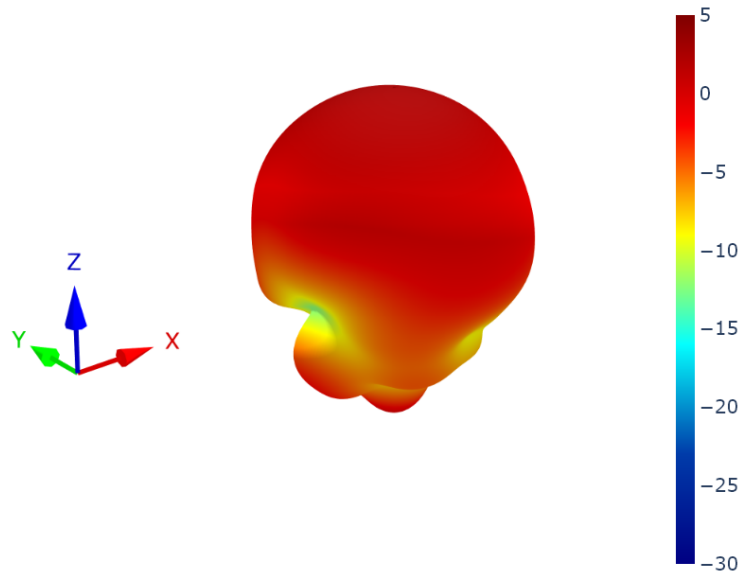



6.4 Passive 70x70mm Ground Plane Patterns at 1602 MHz

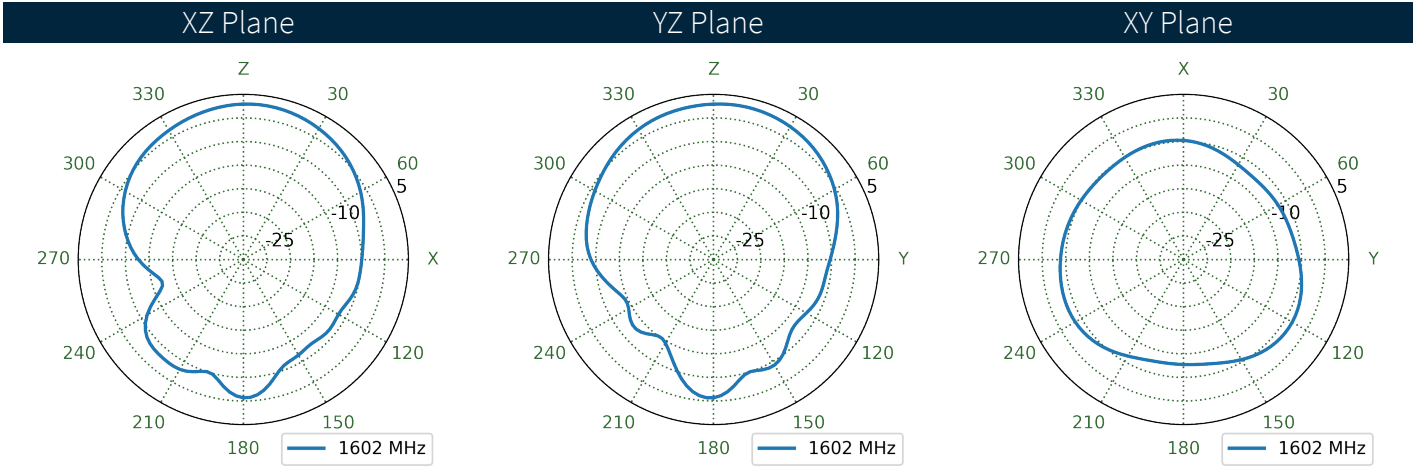
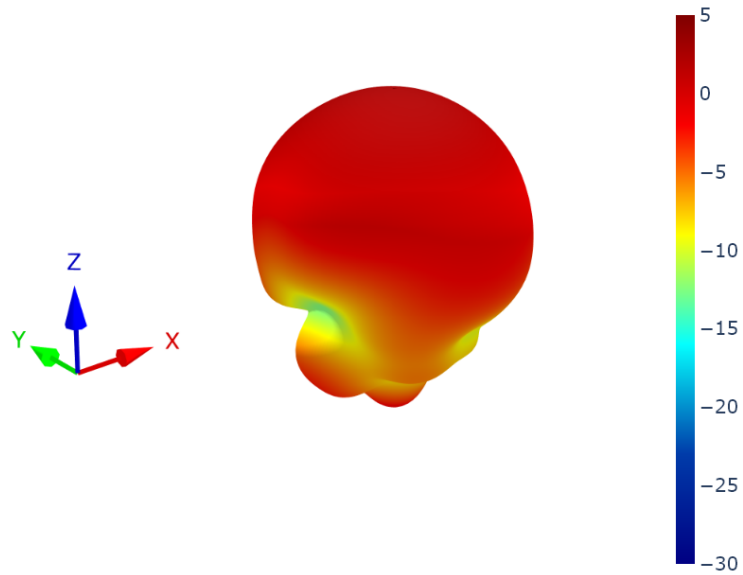

## 7. LNA Characteristics

### 7.1 Block Diagram

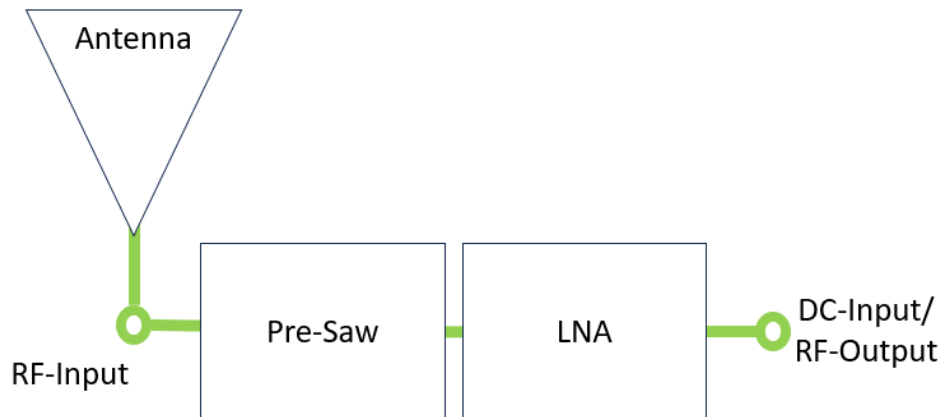

### 7.2 Gain

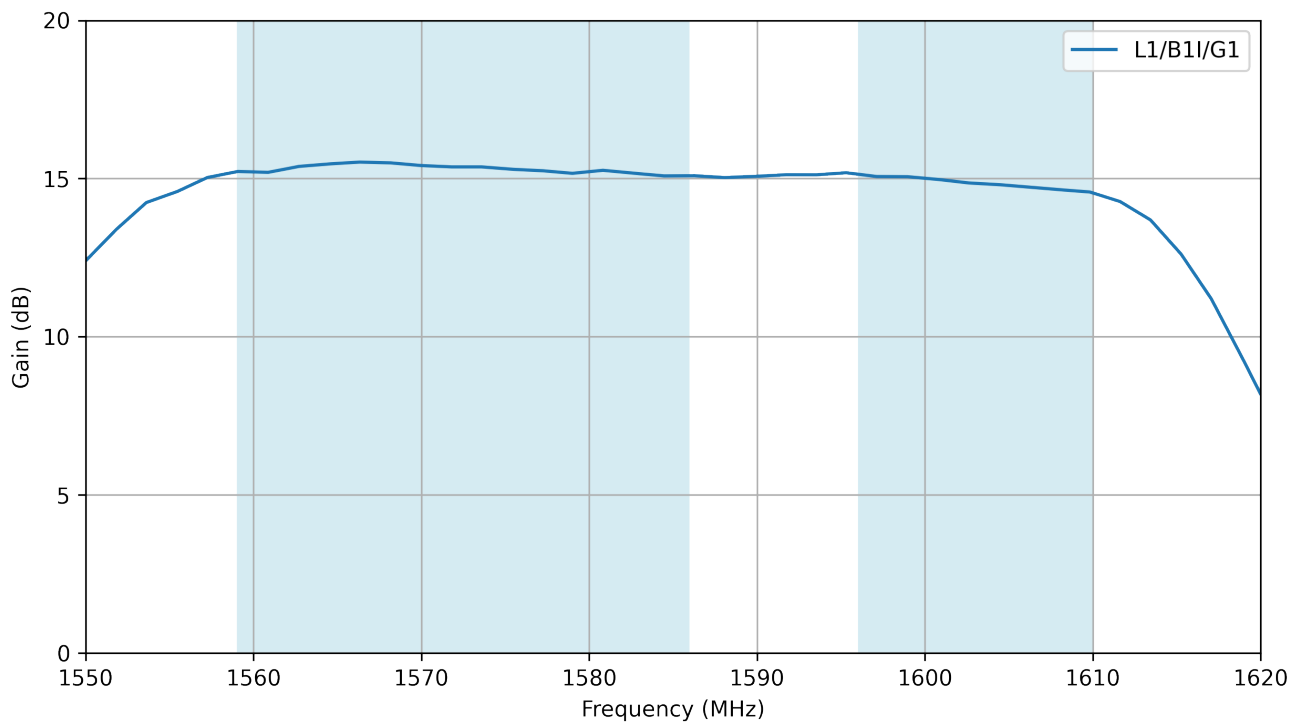

### 7.3 Noise Figure

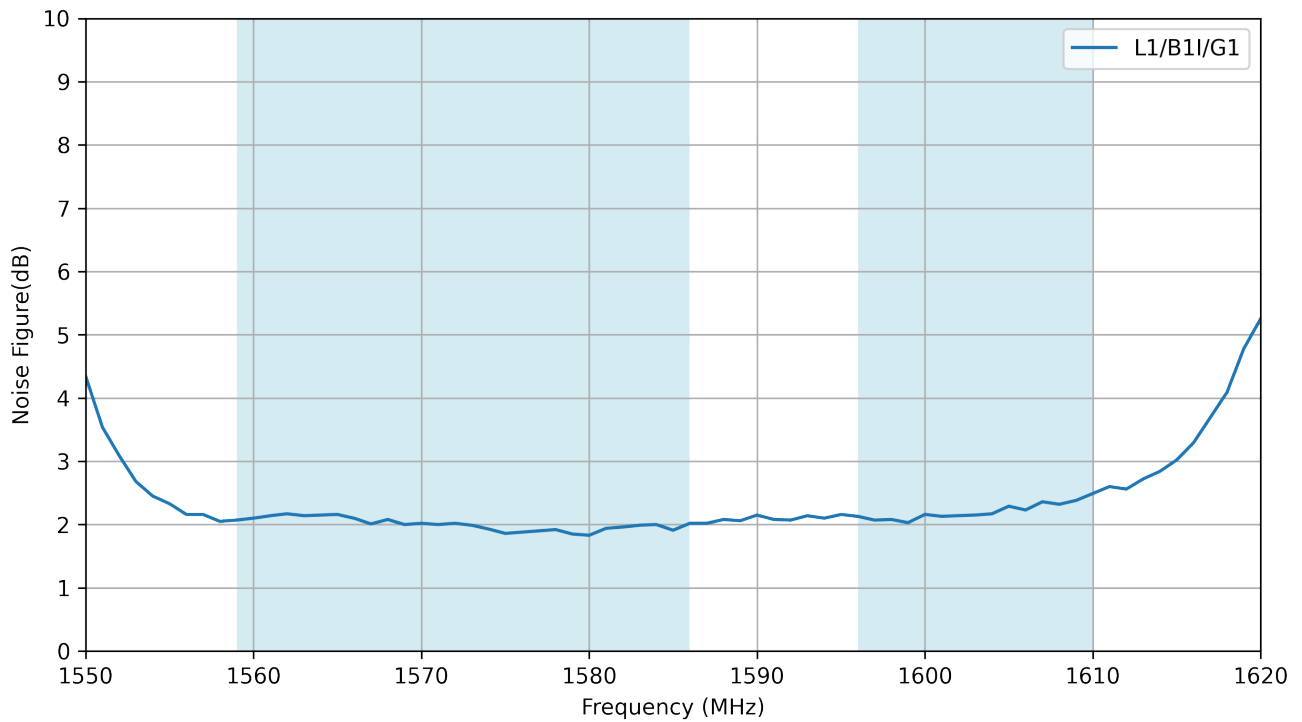

### 7.4 Out Of Band Rejection

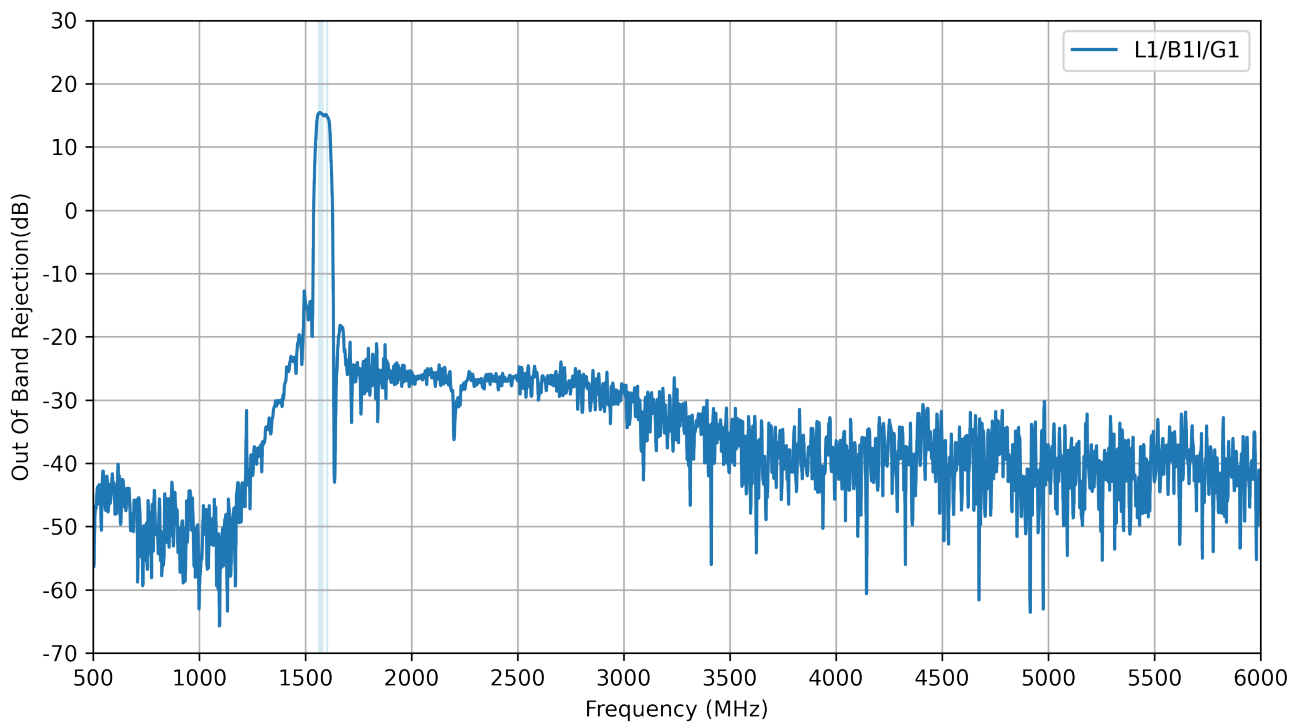

## 7.5 Group Delay

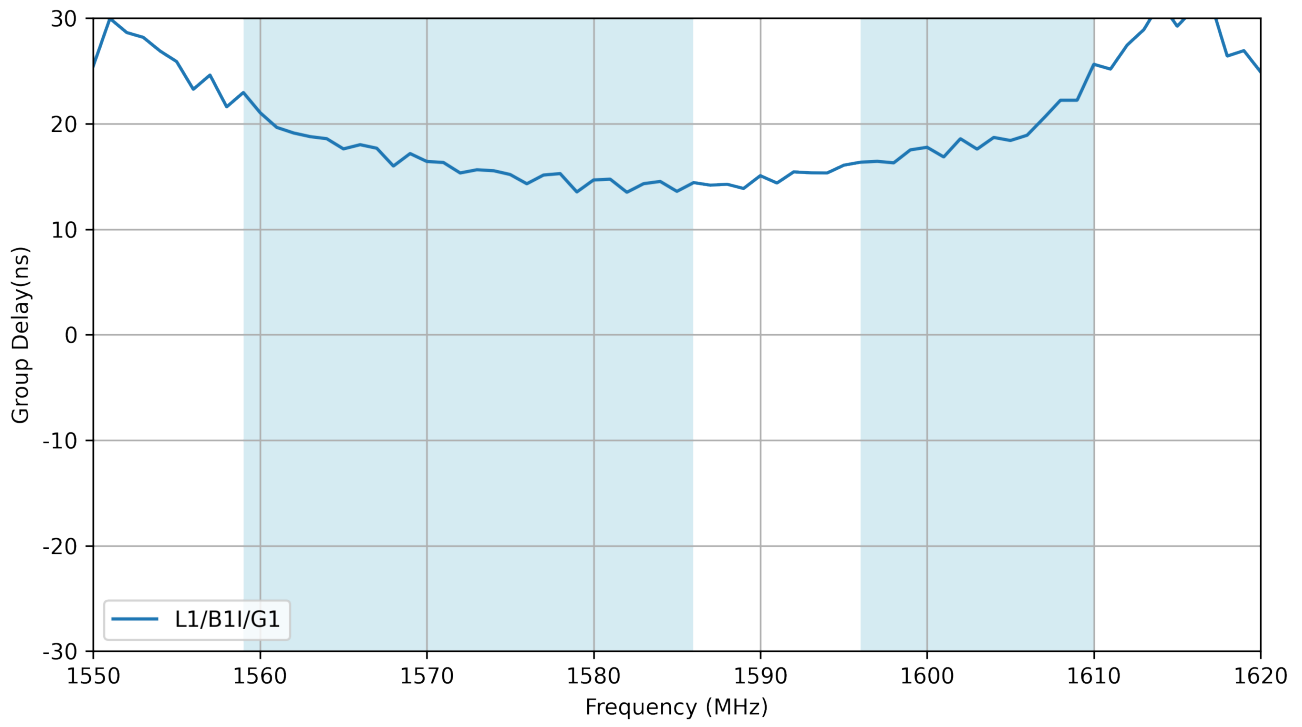

Changelog for the datasheet

**SPE-24-8-298 - AA.185.301111**

**Revision: A (Original First Release)**

Date: 2024-12-12

Notes: Initial Release.

Author: Gary West

**Previous Revisions**



[www.taoglas.com](http://www.taoglas.com)

