



# TAOGLAS®



# Datasheet

## Maximus Series

Part No:

FXUB16.07.0150AQ

## Description

Wideband Cellular 90x15mm Flex PCB Antenna (617-6000MHz)  
with 90° feed Black 150mm 1.37 Cable and I-PEX MHF1

## Features:

Super Small Wideband Cellular Flex PCB Antenna  
Covering Global Cellular Bands from 617-6000MHz  
Dims: 90 x 15 x 0.24mm  
Cable: 150mm of 1.37 Coaxial Cable (Black)  
Connector  
RoHS & Reach Compliant

<b>1.</b>	<b>Introduction</b>	<b>3</b>
<b>2.</b>	<b>Specification</b>	<b>4</b>
<b>3.</b>	<b>Mechanical Drawing</b>	<b>7</b>
<b>4.</b>	<b>Packaging</b>	<b>8</b>
<b>5.</b>	<b>Antenna Characteristics</b>	<b>9</b>
<b>6.</b>	<b>Radiation Patterns</b>	<b>13</b>
<hr/>		
	Changelog	53

Ireland & USA  
ISO 9001:2015  
Certified



Taiwan  
ISO 9001:2015  
Certified



Taoglas makes no warranties based on the accuracy or completeness of the contents of this document and reserves the right to make changes to specifications and product descriptions at any time without notice. Taoglas reserves all rights to this document and the information contained herein. Reproduction, use or disclosure to third parties without express permission is strictly prohibited.

# 1. Introduction



## Super Small, GNSS & Wi-Fi Combination Loop Antenna for the Smallest of IoT Devices

The Maximus Series FXUB16 is the smallest Taoglas wideband flex PCB antenna by footprint size. Engineered to cover all global working frequencies in the 600-6000 MHz spectrum with efficiencies of up to 60%, it is the perfect solution when size constraints limit the use of a larger antenna. It covers all cellular 5G and 4G bands with fall back to 3G/2G, and it also functions for NB-IoT, Cat-M, Wi-Fi, and ISM frequencies. This wide band coverage enables designers to use only one antenna to cover all frequencies and future proofs device design for 5G and 4G globally.

Typical Applications for the FXUB16 include:

- Gateways, Routers and Private LTE Networks
- In-Building Connectivity and Security Systems
- Point of Sales Kiosks and Retail Digital Signage
- Connected Industry and Smart Metering
- Handheld Devices and Tablets
- Mobile Wireless Camera Systems

The antenna is delivered with a flexible body for ease of installation and is supplied with 1.37 micro coax cable and IPEX(TM) MHF1 connector as standard. At just 90.4 × 15 × 0.24mm, the antenna is compact and ultra-thin. It is integrated into a device by a simple “peel and stick” process, attaching securely to non-metal surfaces via strong, 3M adhesive. It is also the ideal antenna to fit in devices that are being retrofitted with wireless functionality, as it will cover non cellular applications such as 868, 915MHz or Zigbee applications. Its inherently wide bandwidth is more resistant to detuning than traditional small but narrow-band legacy antennas. It is an ideal choice for any device maker that needs to keep manufacturing costs down over the lifetime of a product, as the same antenna can be used if the radio module is upgraded to work on a different frequency band.

Cables and Connectors are fully customisable, contact your local Taoglas Customer Services Team for more information.

## 2. Specification

LTE Electrical									
Band	Frequency (MHz)	Measurement	Efficiency (%)	Average Gain (dB)	Peak Gain (dBi)	Impedance	Polarization	Radiation Pattern	Max. input power
5G NR/4G Band 71	617-698	Cable Feed Left	19.9	-7.02	-1.83	50 Ω	Linear	Omni directional	2W
		Cable Feed Right	36.5	-4.38	-0.17				
		Cable Feed Straight	26.6	-5.75	-1.09				
4G/3G Band 12,13,14,17,28,29	698-824	Cable Feed Left	35.2	-4.54	-0.29				
		Cable Feed Right	48.8	-3.11	0.50				
		Cable Feed Straight	41.7	-3.79	0.01				
4G/3G/NB-IoT/Cat M Band 5,8,18,19,20,26,27	824-960	Cable Feed Left	34.6	-4.61	-0.52				
		Cable Feed Right	38.8	-4.11	-0.56				
		Cable Feed Straight	35.4	-4.50	-0.77				
5G NR/4G Band 21,32,74,75,76	1427-1518	Cable Feed Left	13.1	-8.84	-1.72				
		Cable Feed Right	15.3	-8.15	-1.54				
		Cable Feed Straight	13.8	-8.61	-1.83				
4G/3G Band 1,2,3,4,9,23,25,35,39,66	1710-2200	Cable Feed Left	57.1	-2.43	2.53				
		Cable Feed Right	61.7	-2.10	3.00				
		Cable Feed Straight	59.6	-2.25	2.10				
4G/3G Band 7,30,38,40,41	2300-2690	Cable Feed Left	52.9	-2.76	4.06				
		Cable Feed Right	58.3	-2.34	4.10				
		Cable Feed Straight	55.9	-2.53	3.61				
5G NR/4G Band 22,42,48,77,78,79	3300-5000	Cable Feed Left	49.6	-3.05	5.35				
		Cable Feed Right	53.2	-2.74	5.94				
		Cable Feed Straight	51.8	-2.86	6.05				
LTE5200/Wi-Fi5800	5150-5925	Cable Feed Left	44.5	-3.52	5.24				
		Cable Feed Right	45.8	-3.39	6.32				
		Cable Feed Straight	46.8	-3.30	5.90				

5G/4G Bands					
Band Number	5G NR / FR1 / LTE / LTE-Advanced / WCDMA / HSPA / HSPA+ / TD-SCDMA				
	Uplink	Downlink	Cable Feed Left	Cable Feed Right	Cable Feed Straight
B1	1920 to 1980	2110 to 2170	✓	✓	✓
B2	1850 to 1910	1930 to 1990	✓	✓	✓
B3	1710 to 1785	1805 to 1880	✓	✓	✓
B4	1710 to 1755	2110 to 2155	✓	✓	✓
B5	824 to 849	869 to 894	✓	✓	✓
B7	2500 to 2570	2620 to 2690	✓	✓	✓
B8	880 to 915	925 to 960	✓	✓	✓
B9*	1749.9 to 1784.9	1844.9 to 1879.9	✓	✓	✓
B11	1427.9 to 1447.9	1475.9 to 1495.9	✗	✗	✗
B12	699 to 716	729 to 746	✓	✓	✓
B13	777 to 787	746 to 756	✓	✓	✓
B14	788 to 798	758 to 768	✓	✓	✓
B17	704 to 716	734 to 746	✓	✓	✓
B18	815 to 830	860 to 875	✓	✓	✓
B19	830 to 845	875 to 890	✓	✓	✓
B20	832 to 862	791 to 821	✓	✓	✓
B21	1447.9 to 1462.9	1495.9 to 1510.9	✗	✗	✗
B22*	3410 to 3490	3510 to 3590	✓	✓	✓
B23*	2000 to 2020	2180 to 2200	✓	✓	✓
B24	1626.5 to 1660.5	1525 to 1559	✓	✓	✓
B25	1850 to 1915	1930 to 1995	✓	✓	✓
B26	814 to 849	859 to 894	✓	✓	✓
B27*	807 to 824	852 to 869	✓	✓	✓
B28	703 to 748	758 to 803	✓	✓	✓
B29		717 to 728	✓	✓	✓
B30	2305 to 2315	2350 to 2360	✓	✓	✓
B31	452.5 to 457.5	462.5 to 467.5	✗	✗	✗
B32		1452 to 1496	✗	✗	✗
B34		2010 to 2025	✓	✓	✓
B35		1850 to 1910	✓	✓	✓
B36		1930 to 1990	✓	✓	✓
B37		1910 to 1930	✓	✓	✓
B38		2570 to 2620	✓	✓	✓
B39		1880 to 1920	✓	✓	✓
B40		2300 to 2400	✓	✓	✓
B41		2496 to 2690	✓	✓	✓
B42		3400 to 3600	✓	✓	✓
B43		3600 to 3800	✓	✓	✓
B45		1447 to 1467	✗	✗	✗
B46		5150 to 5925	✓	✓	✓
B47		5855 to 5925	✓	✓	✓
B48		3550 to 3700	✓	✓	✓
B49		3550 to 3700	✓	✓	✓
B50		1432 to 1517	✗	✗	✗
B51		1427 to 1432	✗	✓	✓
B52		3300 to 3400	✓	✓	✓
B53		2483.5 to 2495	✓	✓	✓
B65	1920 to 2010	2110 to 2200	✓	✓	✓
B66	1710 to 1780	2110 to 2200	✓	✓	✓
B68	698 to 728	753 to 783	✓	✓	✓
B69		2570 to 2620	✓	✓	✓
B70	1695 to 1710	1995 to 2020	✓	✓	✓
B71	663 to 698	617 to 652	✗	✓	✓
B72	451 to 456	461 to 466	✗	✗	✗
B73	450 to 455	460 to 465	✗	✗	✗
B74	1427 to 1470	1475 to 1518	✗	✗	✗
B75		1432 to 1517	✗	✗	✗
B76		1427 to 1432	✗	✓	✓
B77		3300 to 4200	✓	✓	✓
B78		3300 to 3800	✓	✓	✓
B79		4400 to 5000	✓	✓	✓
B85	698 to 716	728 to 746	✓	✓	✓
B87	410 to 415	420 to 425	✗	✗	✗
B88	412 to 417	422 to 427	✗	✗	✗

### Mechanical

<b>Dimensions</b>	90 x 15 x 0.24mm
<b>Weight</b>	--
<b>Material</b>	Flexible PCB
<b>Connector</b>	IPEX MHF1
<b>Cable</b>	150mm of 1.37 Coaxial

### Environmental

<b>Operation Temperature</b>	-40°C to 85°C
<b>Storage Temperature</b>	-40°C to 85°C
<b>Relative Humidity</b>	Non-condensing 65°C 95% RH

### 3. Mechanical Drawing

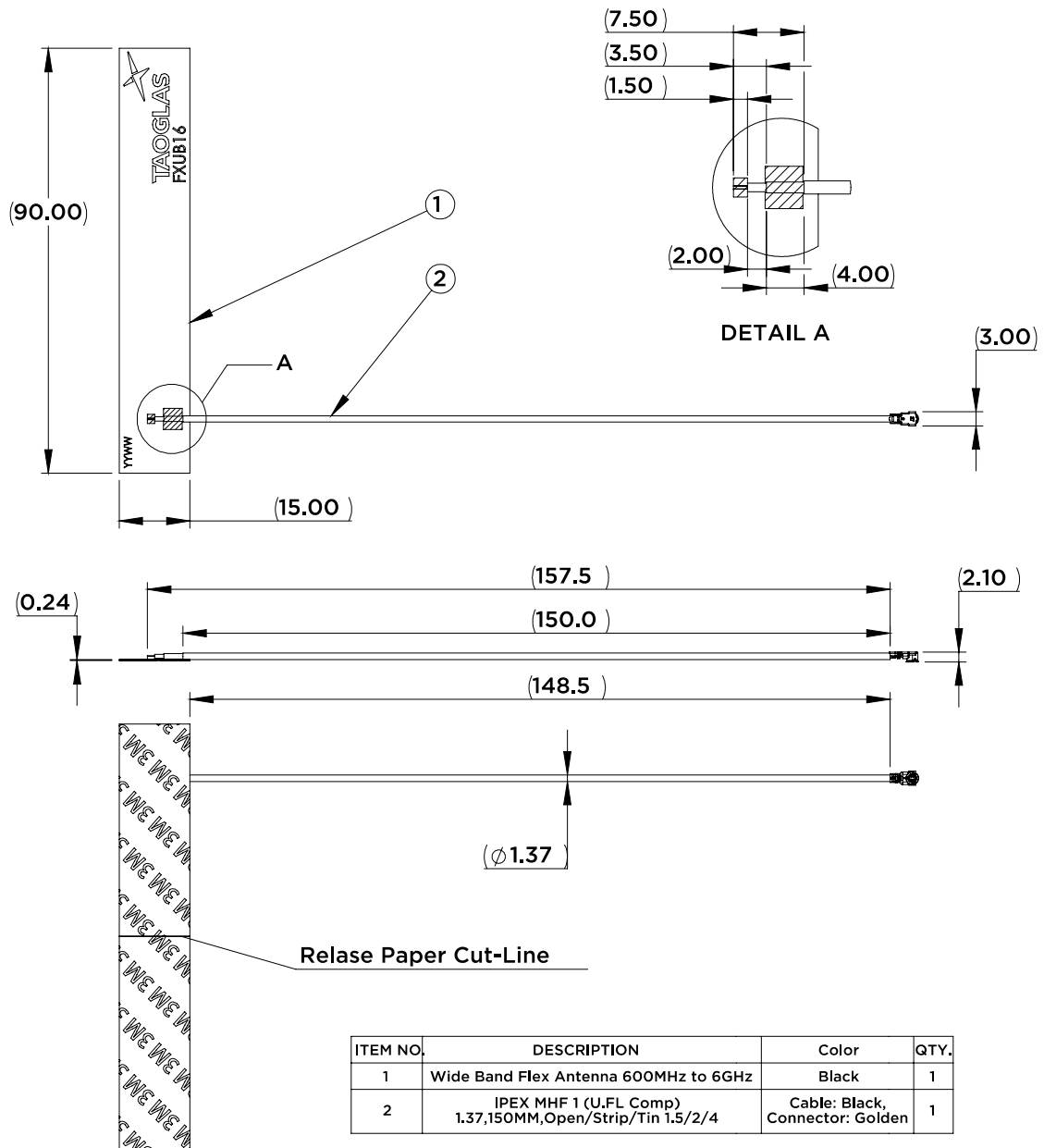

## 4. Packaging

100pcs per PE bag  
 Bag dimensions: 180 x 265mm  
 Weight: 0.13Kg



3000pcs per carton  
 Carton dimensions: 360 x 310 x 160mm  
 Weight: 4.45Kg





## 5. Antenna Characteristics

### 5.1 Test Setup

AUT



Vector Network Analyzer

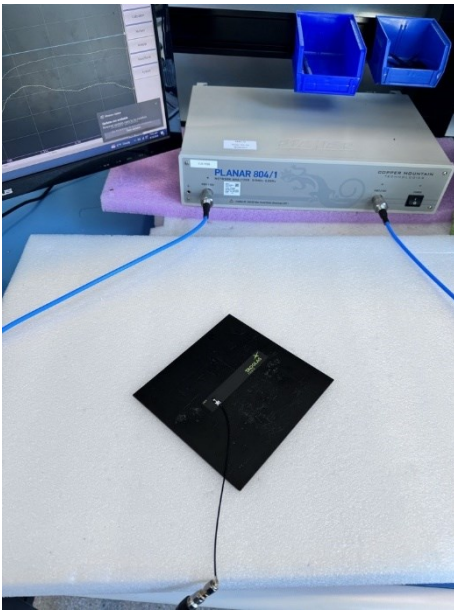

Cable Feed Left

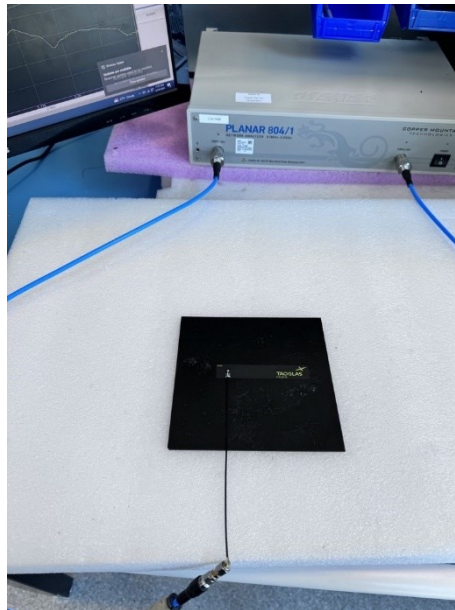

Cable Feed Straight

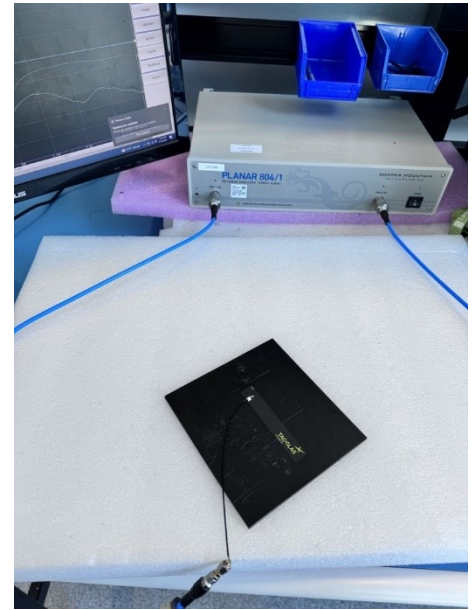

Cable Feed Right

## 5.2 Return Loss

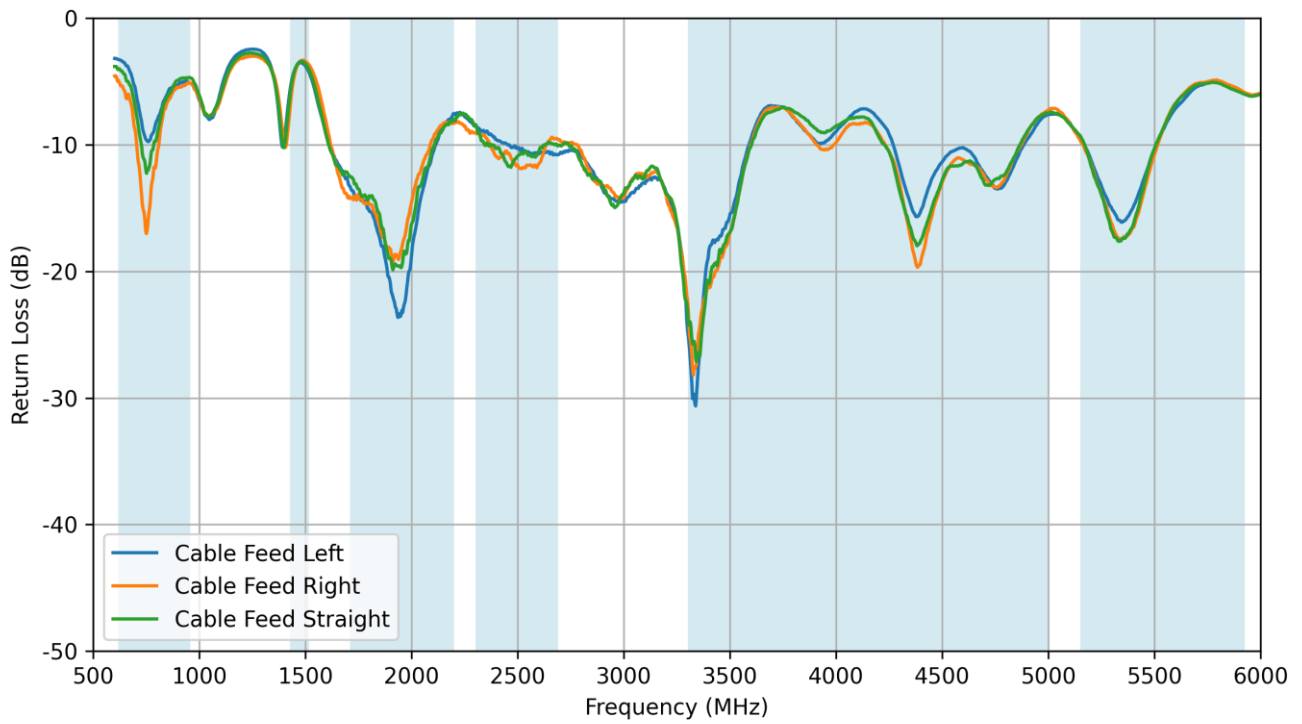

## 5.3 VSWR

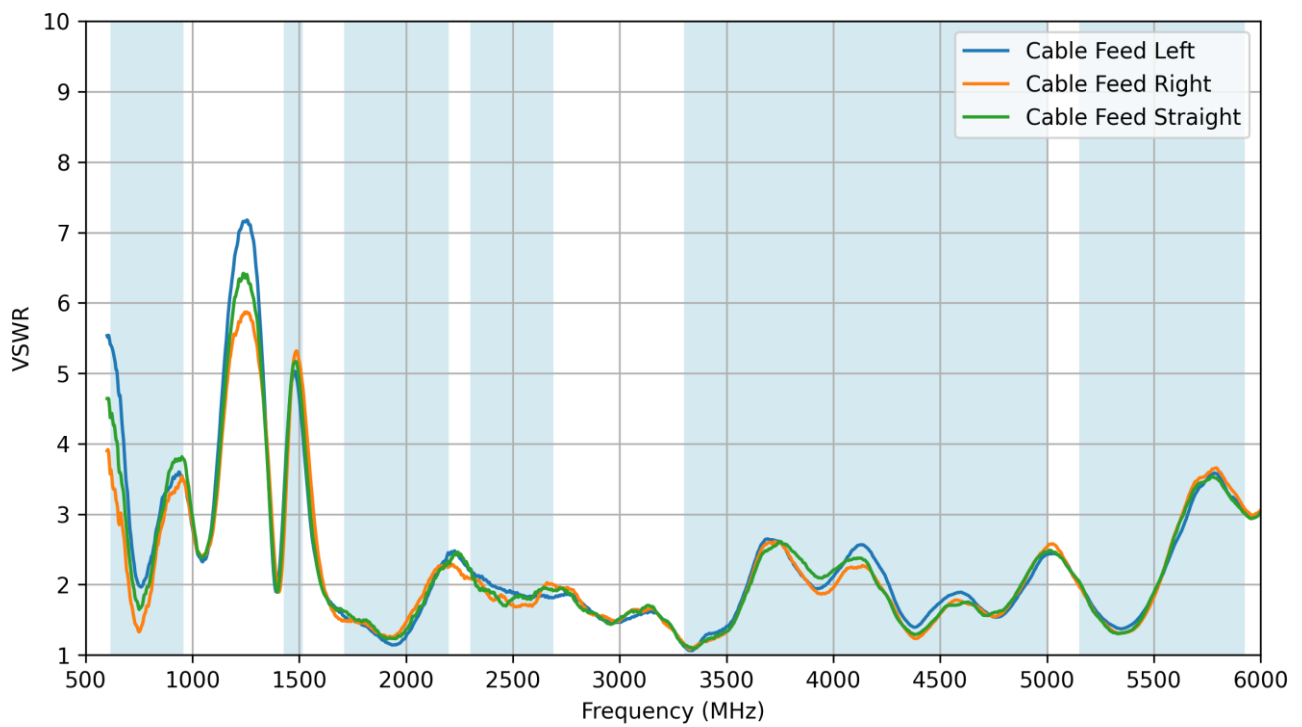

## 5.4 Efficiency

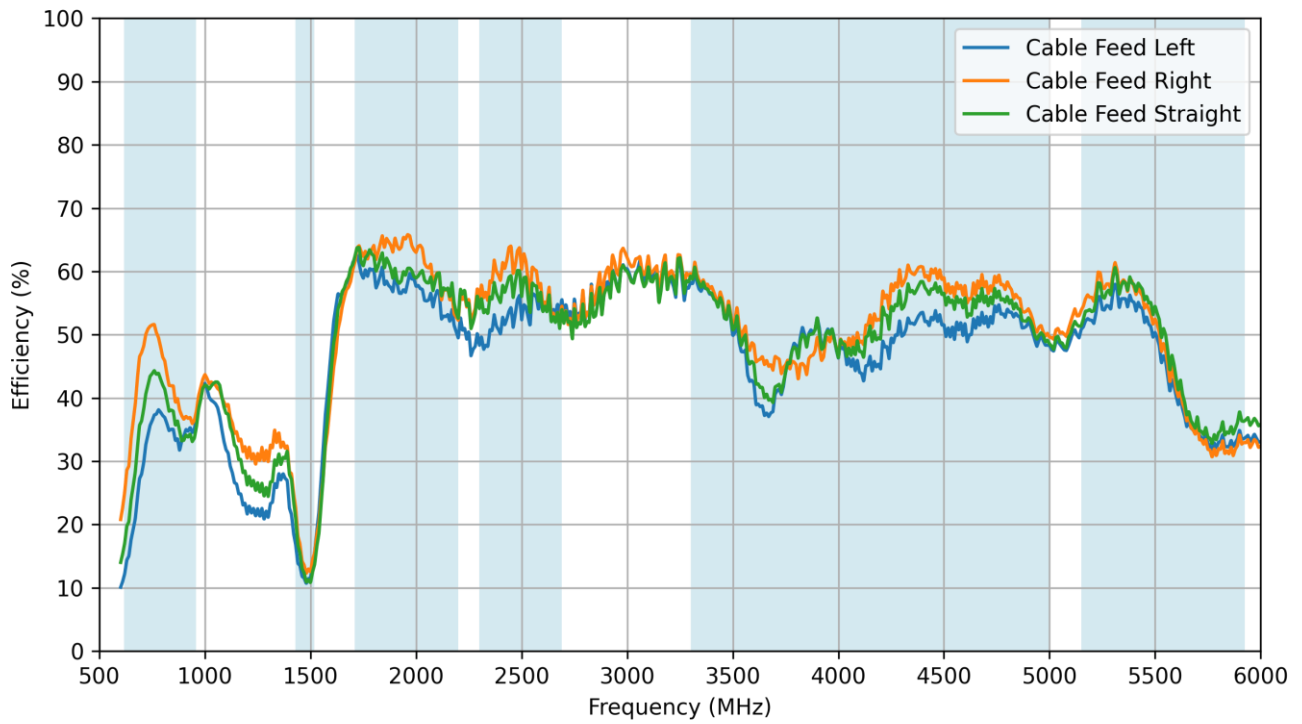

## 5.5 Average Gain

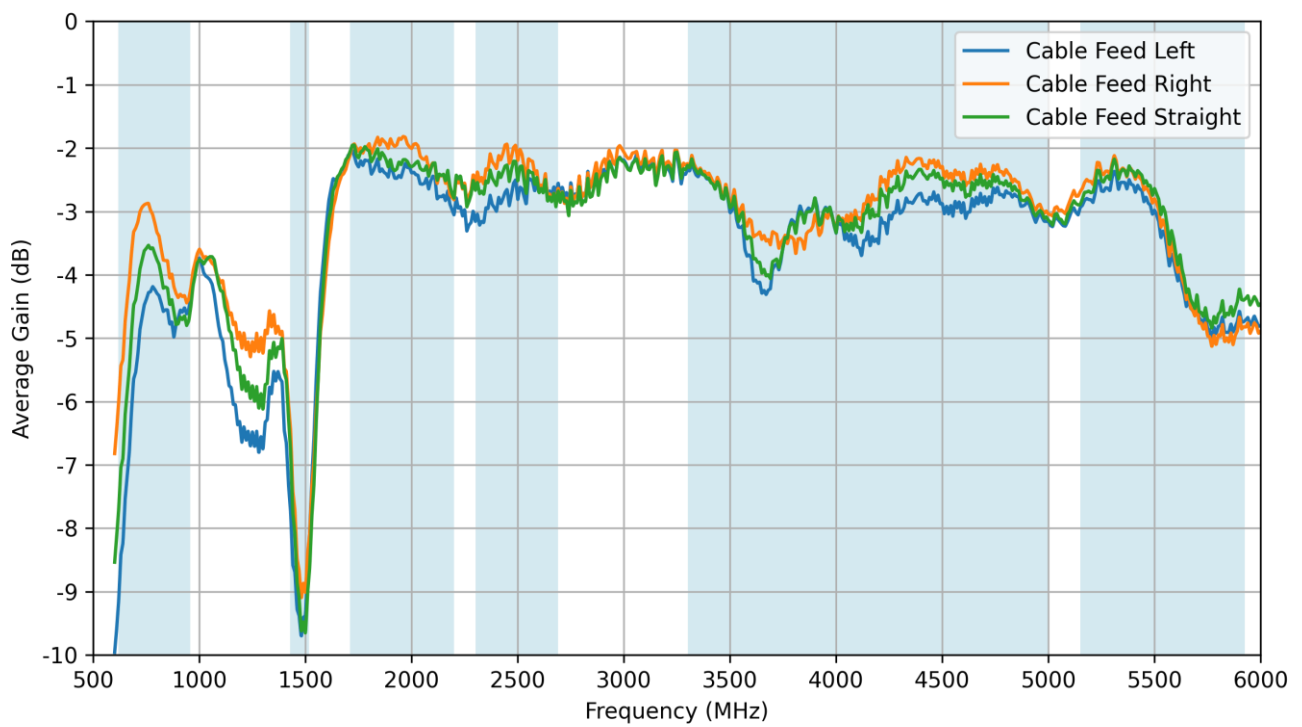

## 5.6 Peak Gain

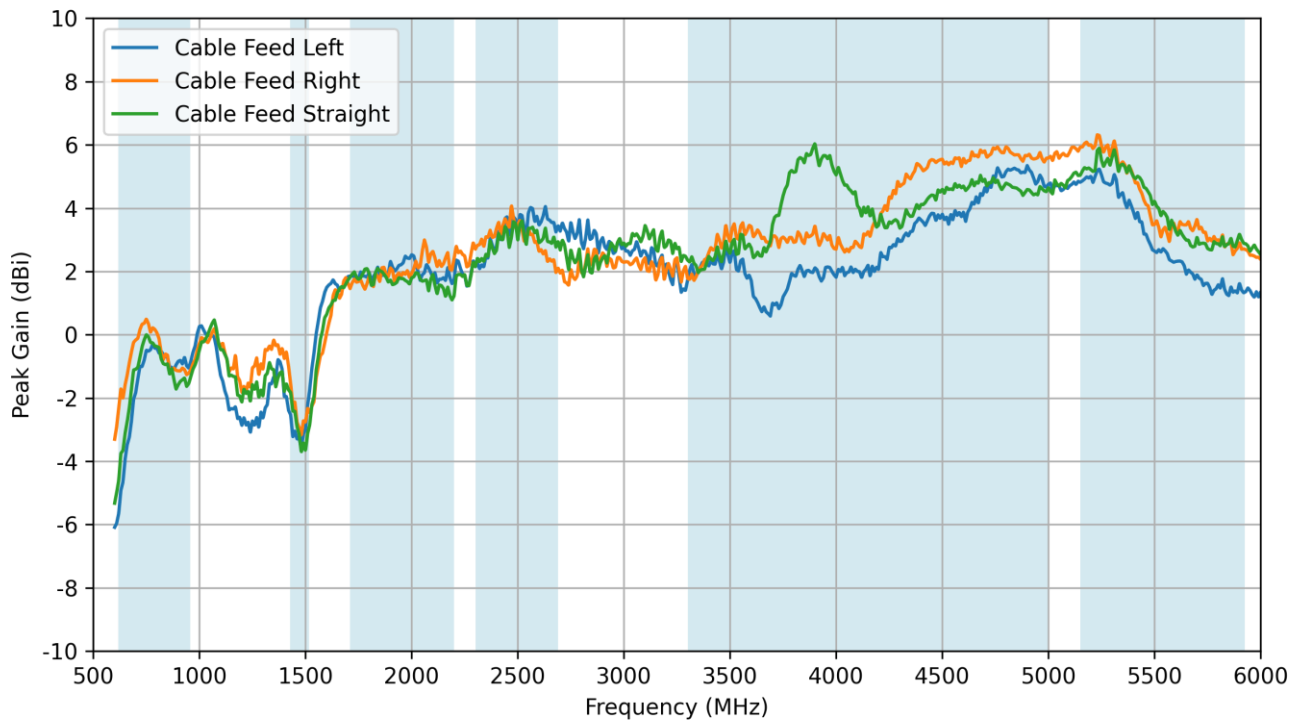

## 6. Radiation Patterns

### 6.1 Test Setup

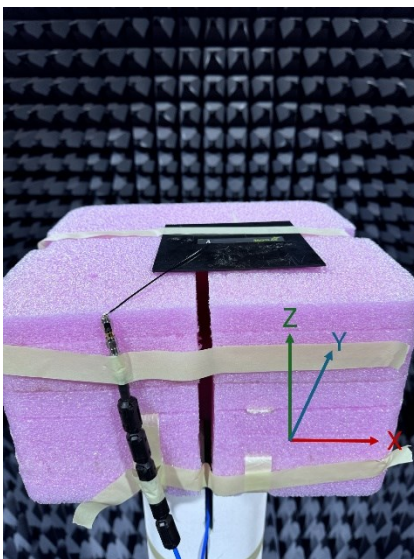
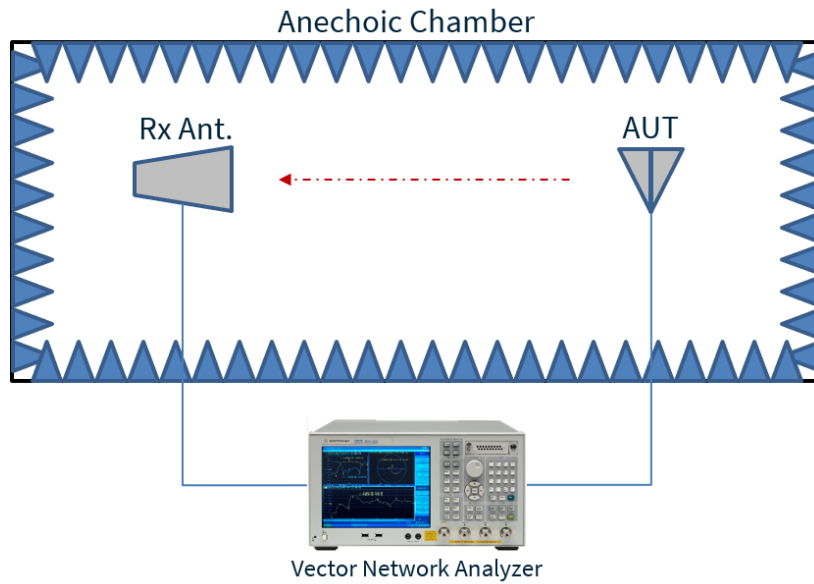

Cable Feed Left

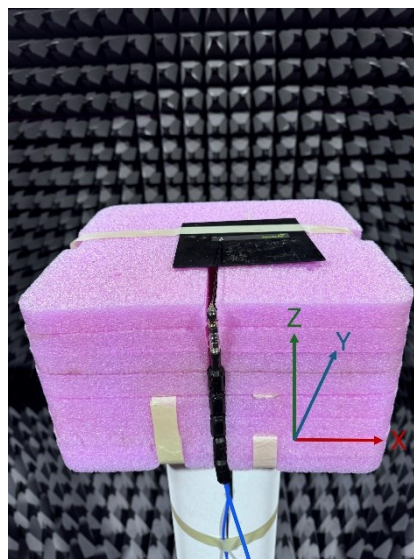

Cable Feed Straight

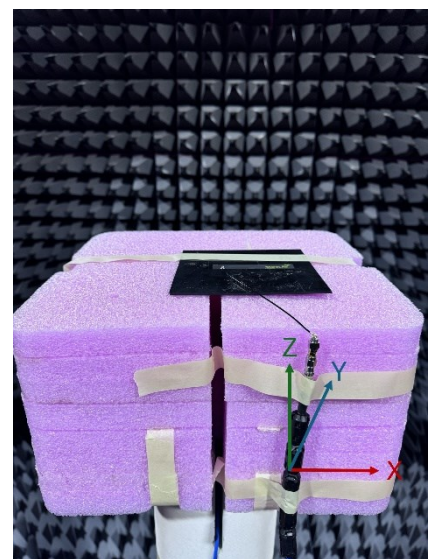

Cable Feed Right

6.2 Cable Feed Left Patterns at 650 MHz

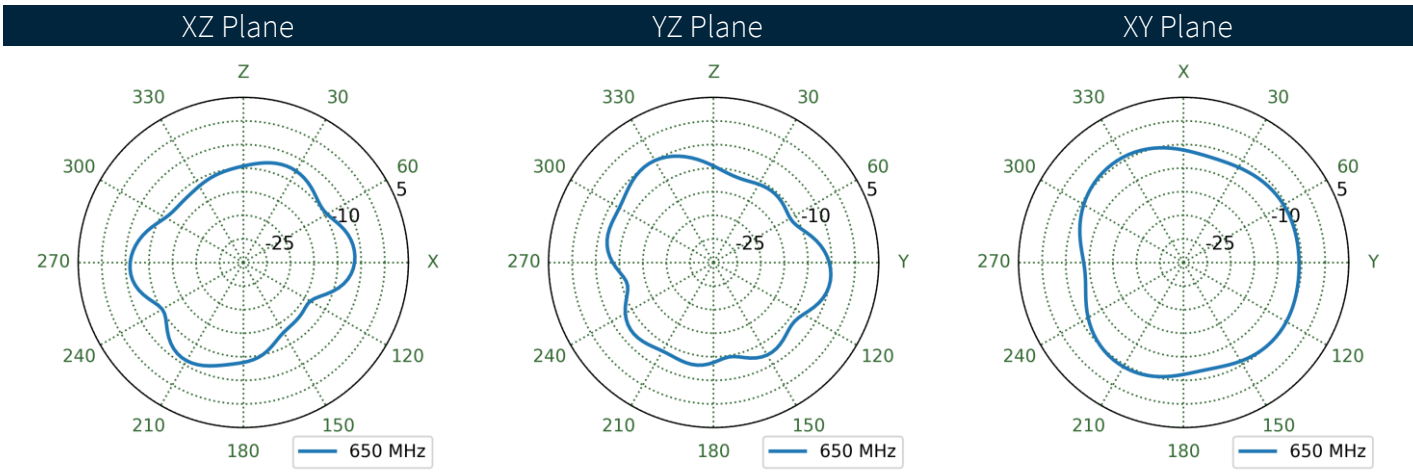
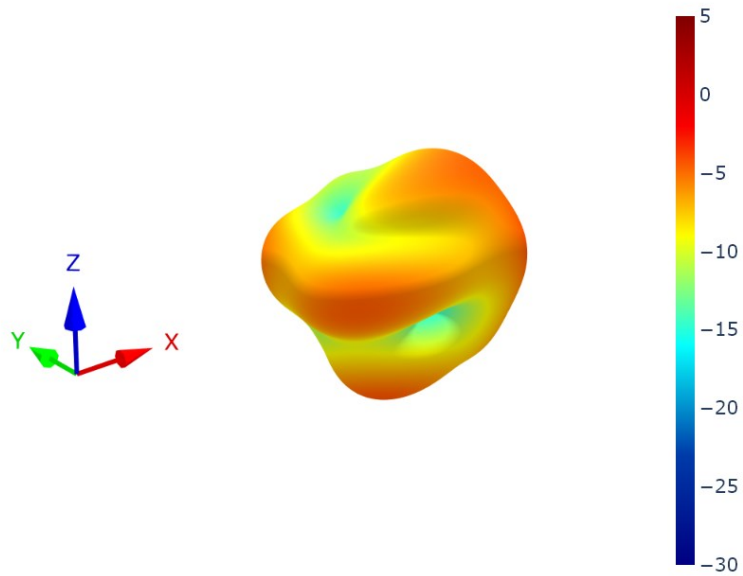

6.3 Cable Feed Right Patterns at 650 MHz

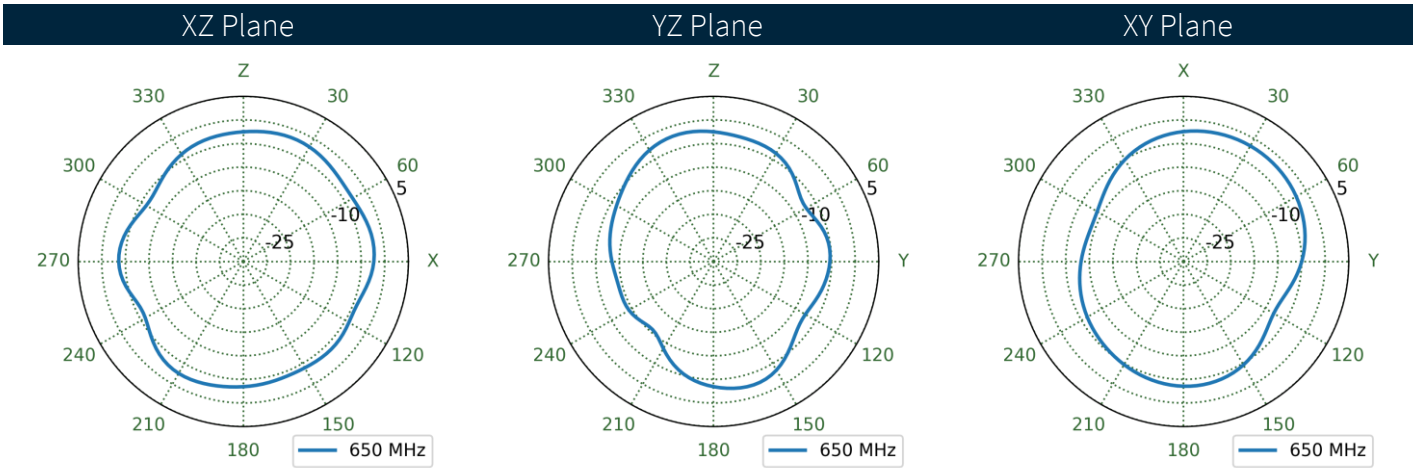
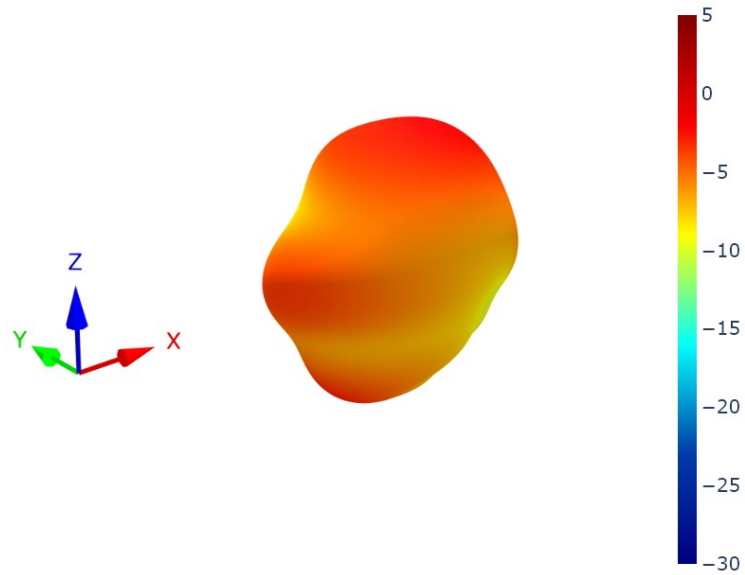

6.4 Cable Feed Straight Patterns at 650 MHz

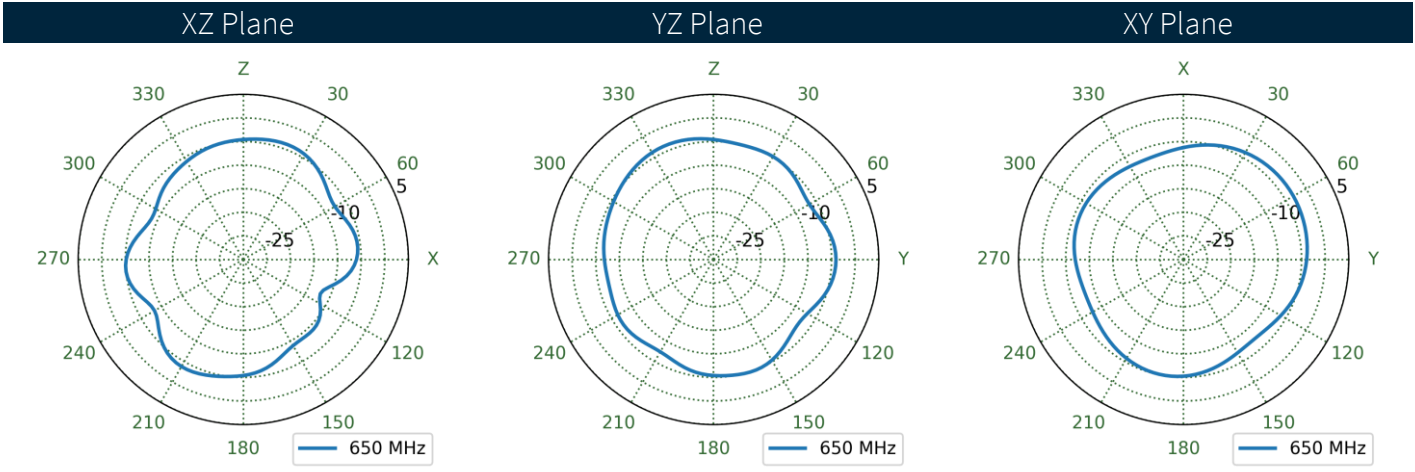
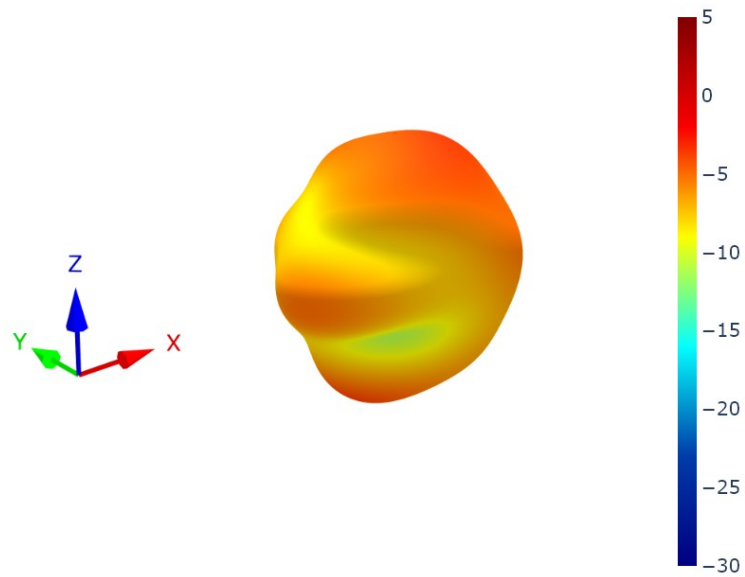



6.5 Cable Feed Left Patterns at 750 MHz

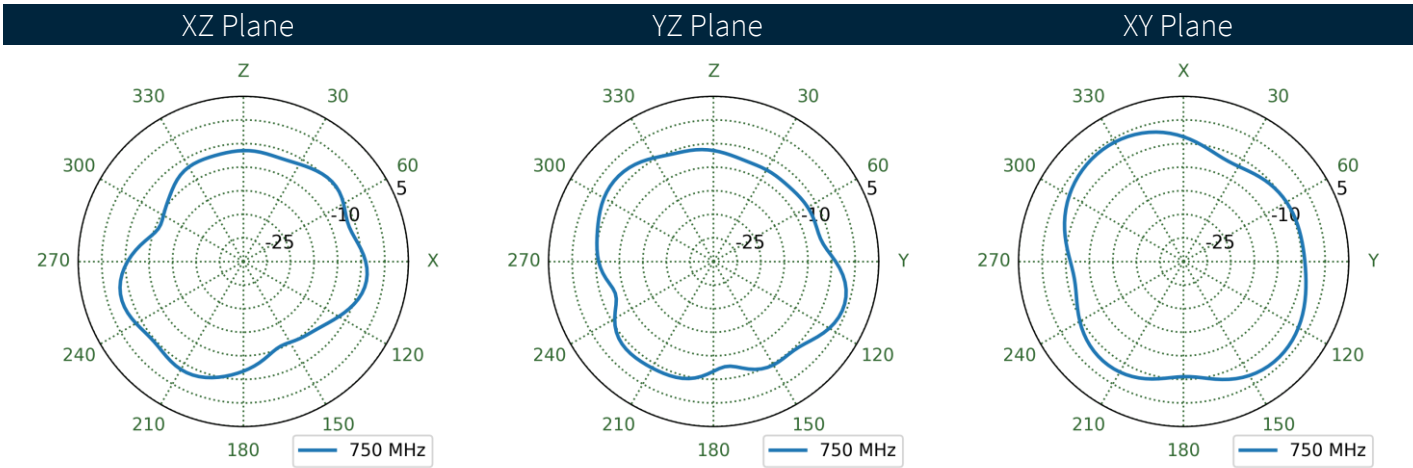
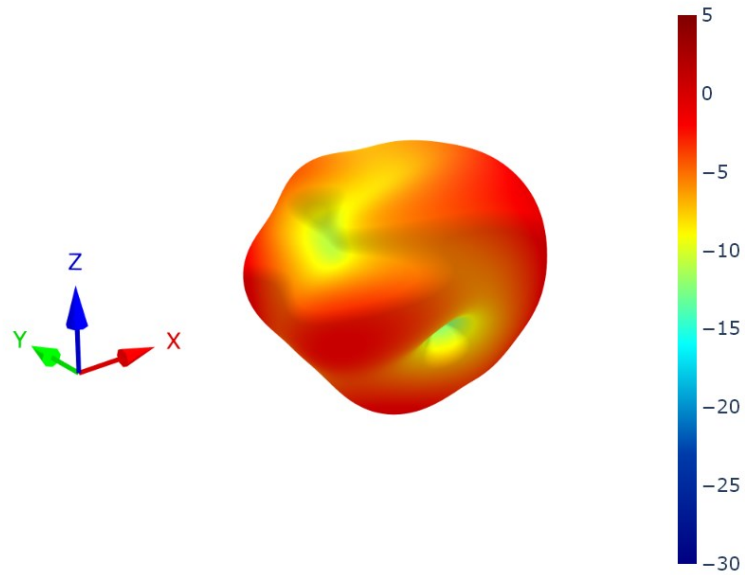

6.6 Cable Feed Right Patterns at 750 MHz

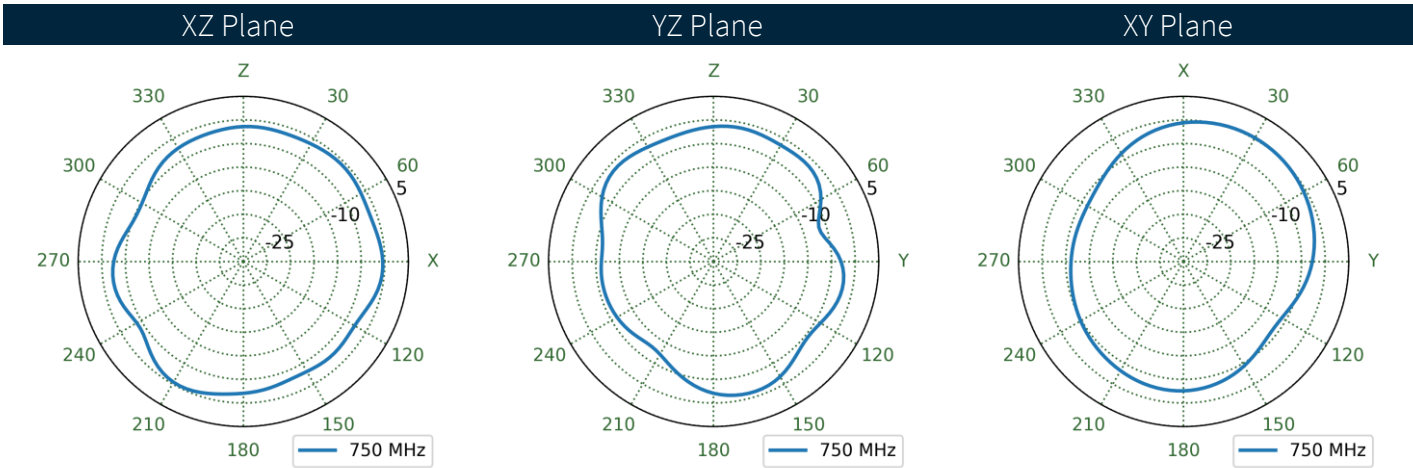
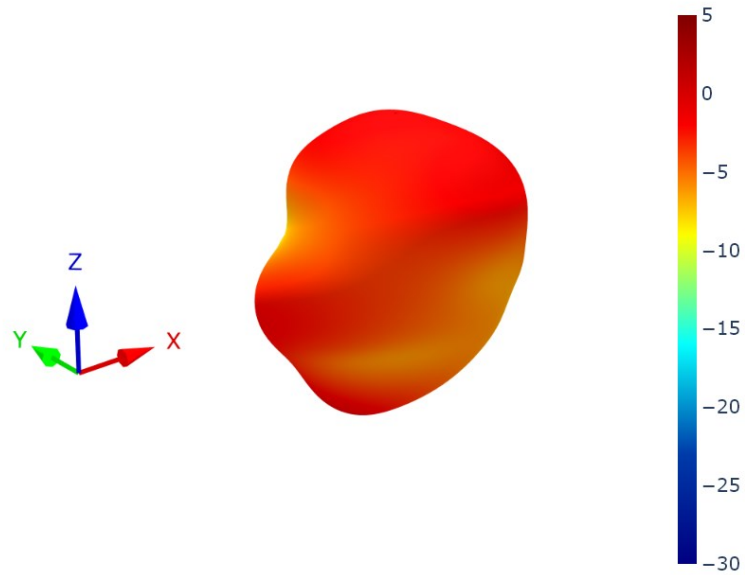

6.7 Cable Feed Straight Patterns at 750 MHz

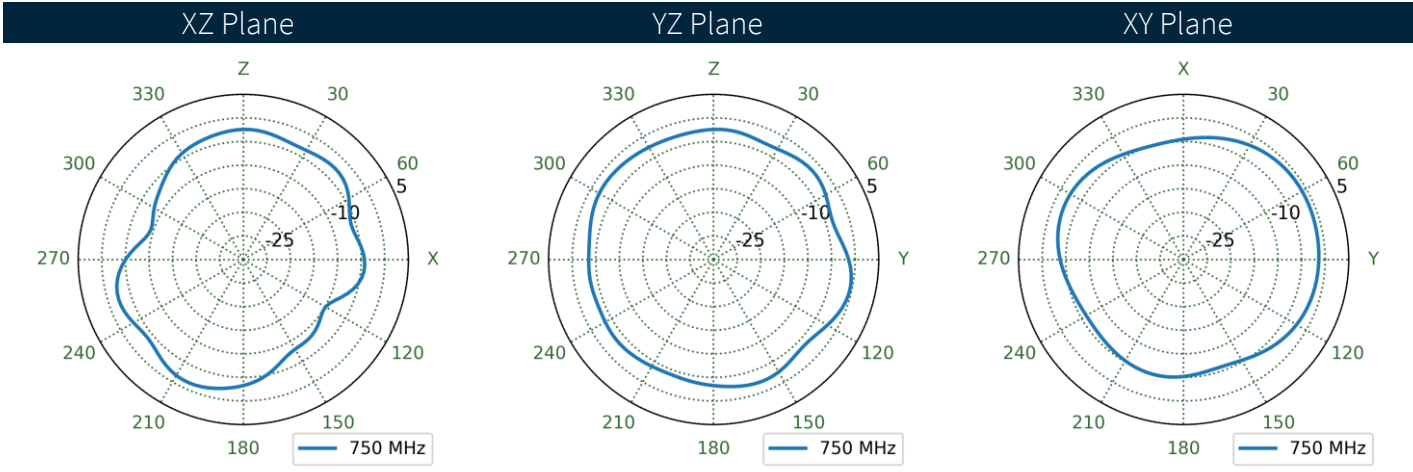
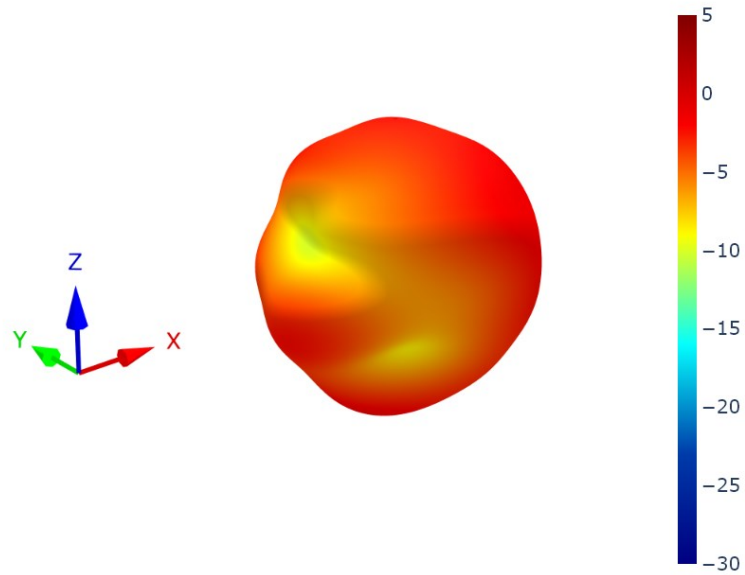

6.8 Cable Feed Left Patterns at 890 MHz

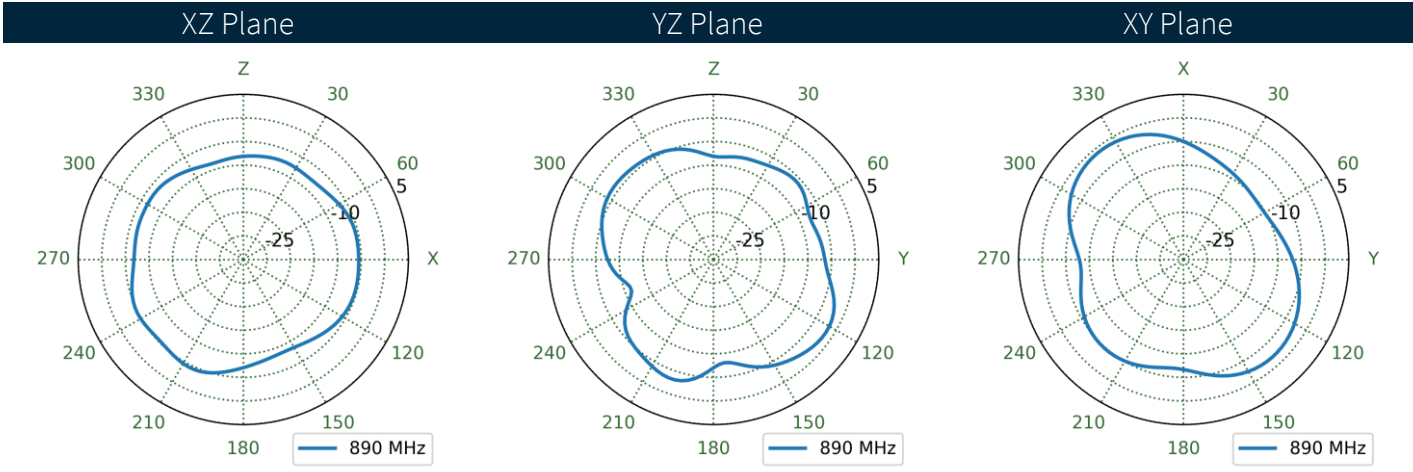
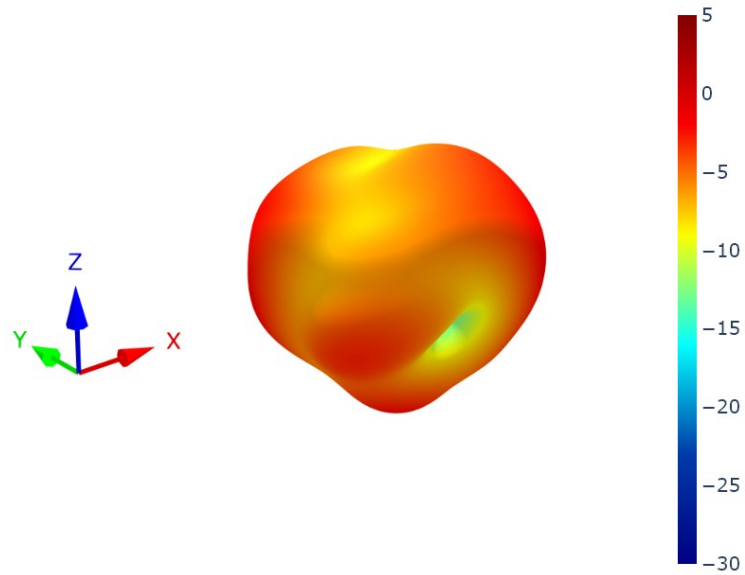

6.9 Cable Feed Right Patterns at 890 MHz

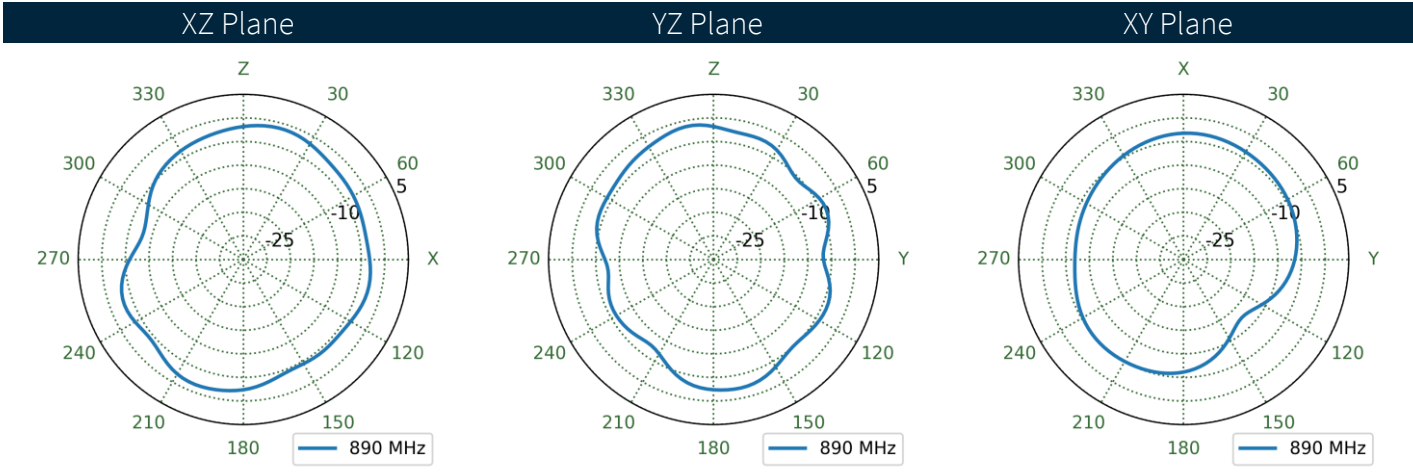
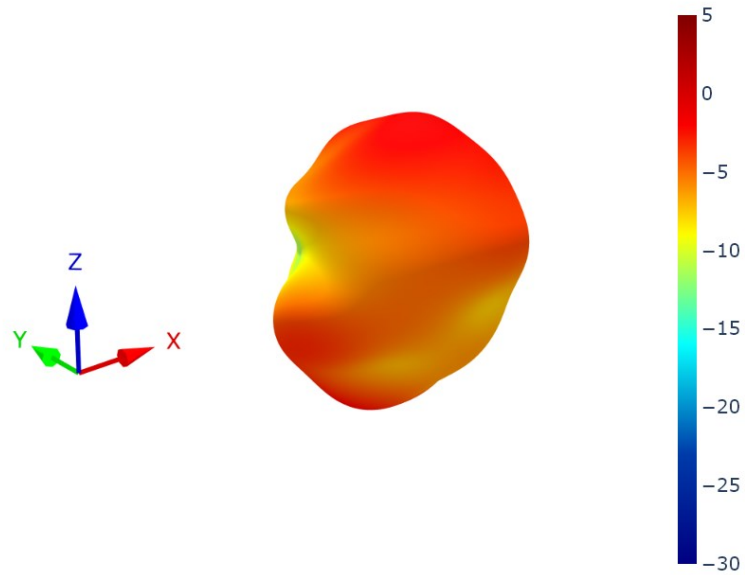

**6.10** Cable Feed Straight Patterns at 890 MHz

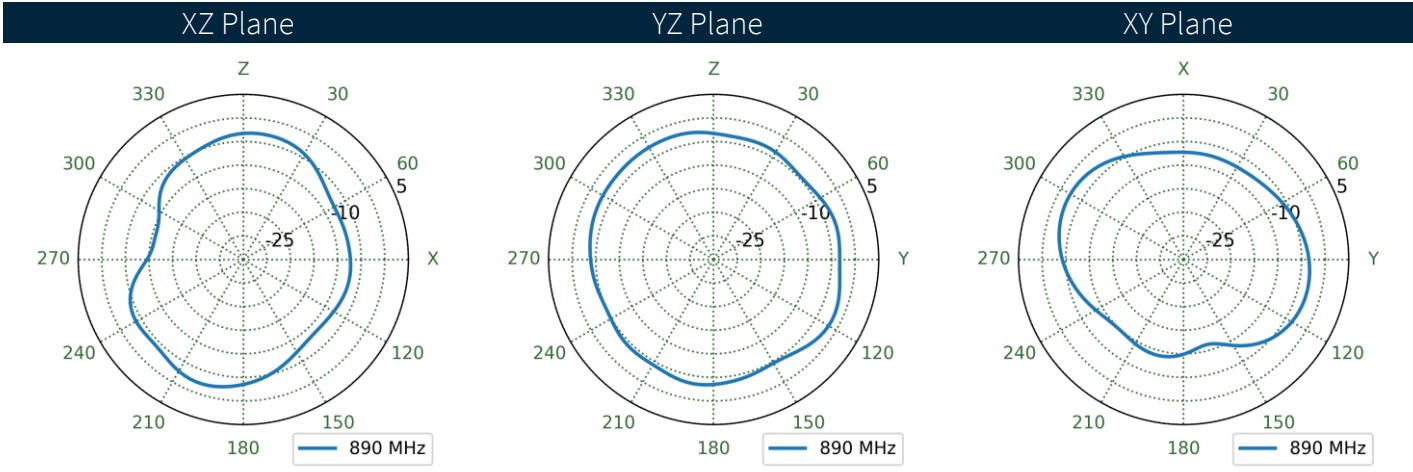
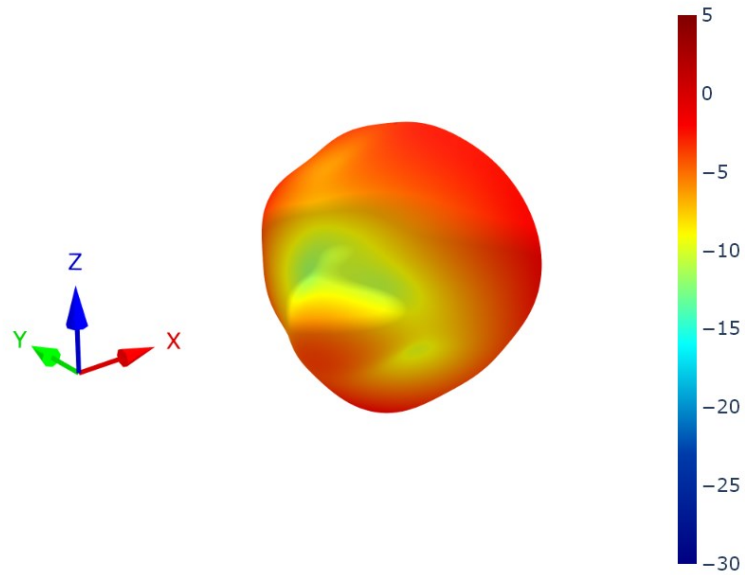

6.11 Cable Feed Left Patterns at 1470 MHz

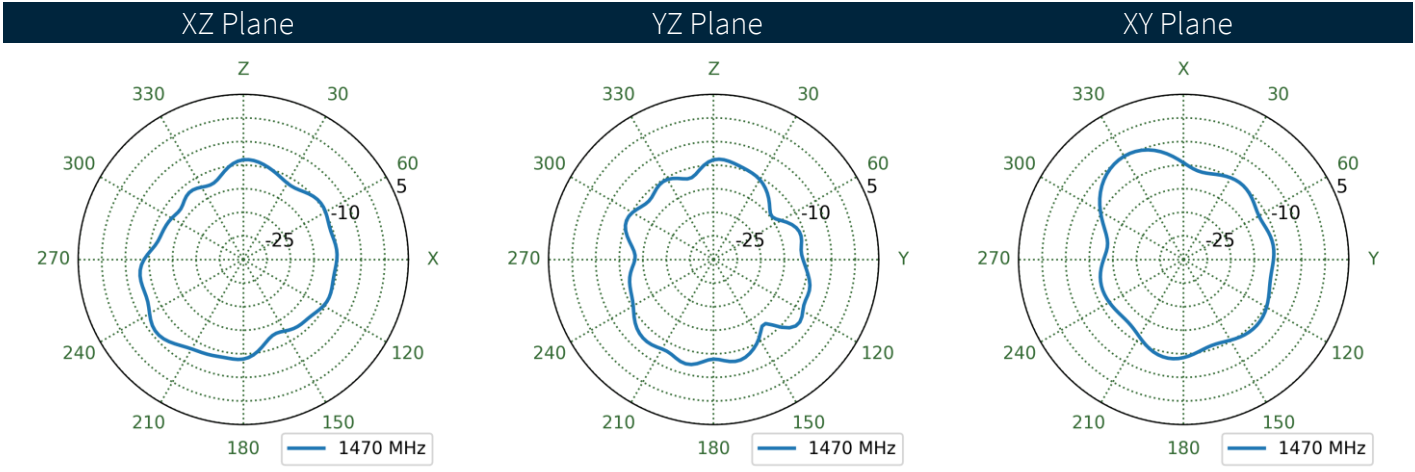
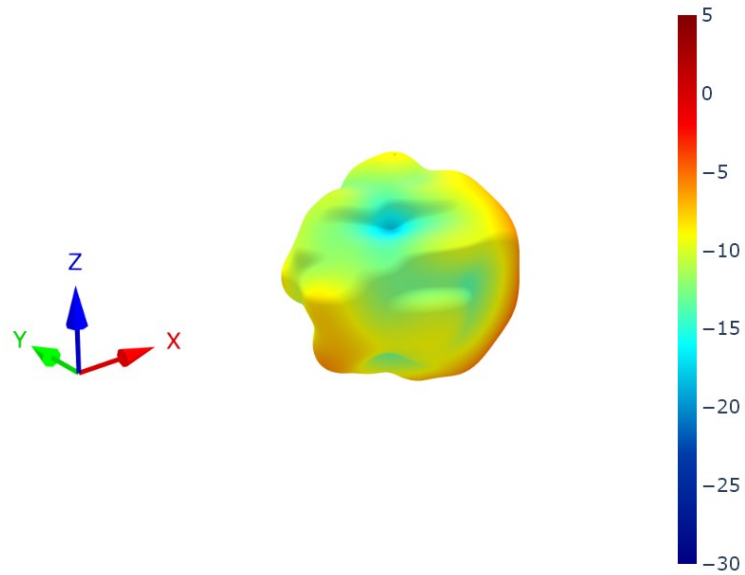

**6.12** Cable Feed Right Patterns at 1470 MHz

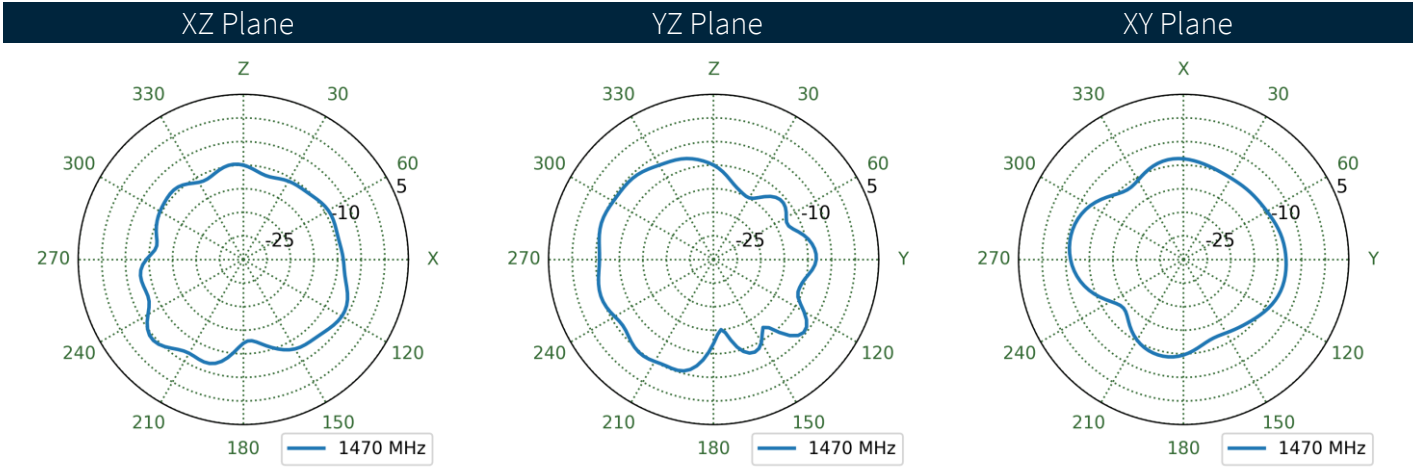
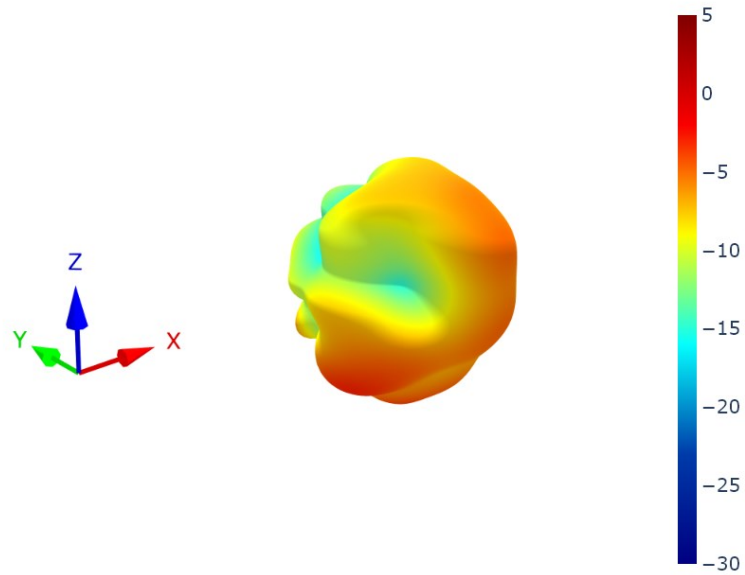



6.13 Cable Feed Straight Patterns at 1470 MHz

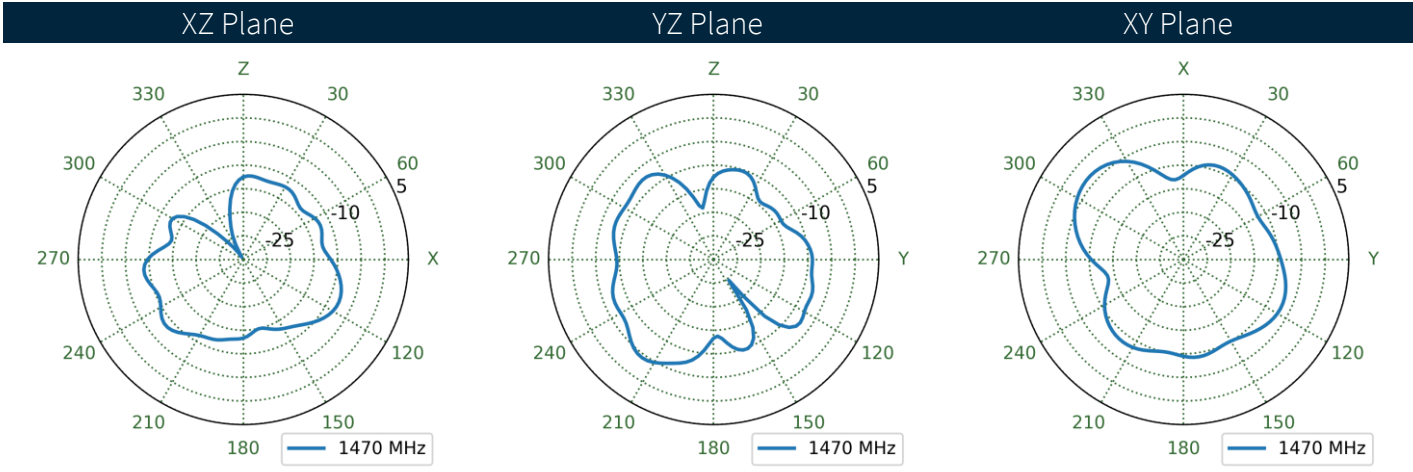
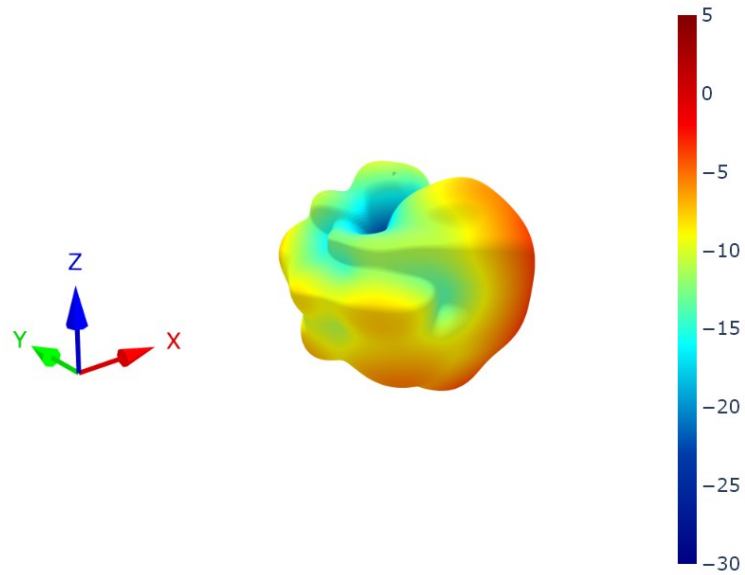

6.14 Cable Feed Left Patterns at 1805 MHz

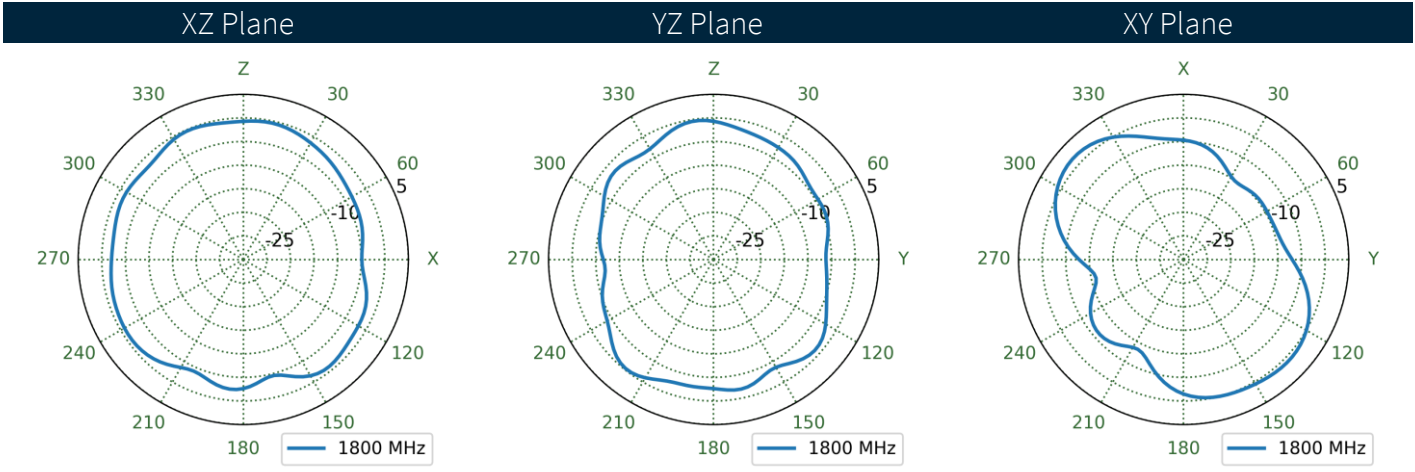
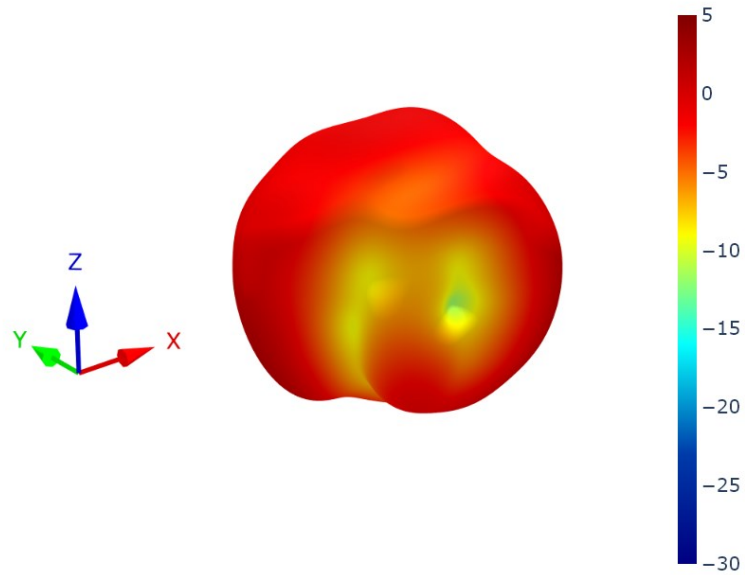

**6.15** Cable Feed Right Patterns at 1805 MHz

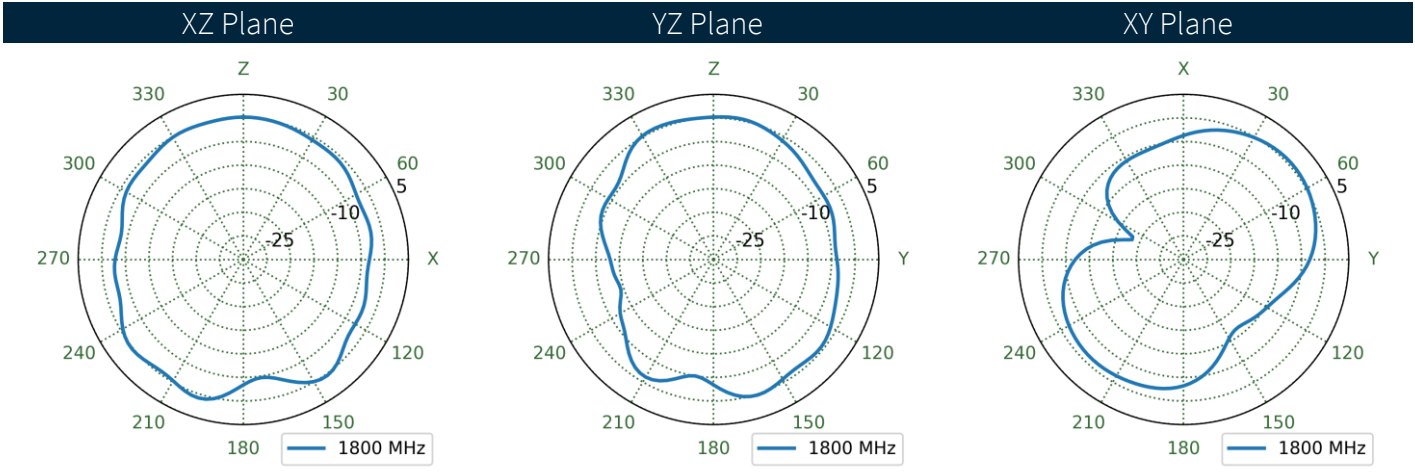
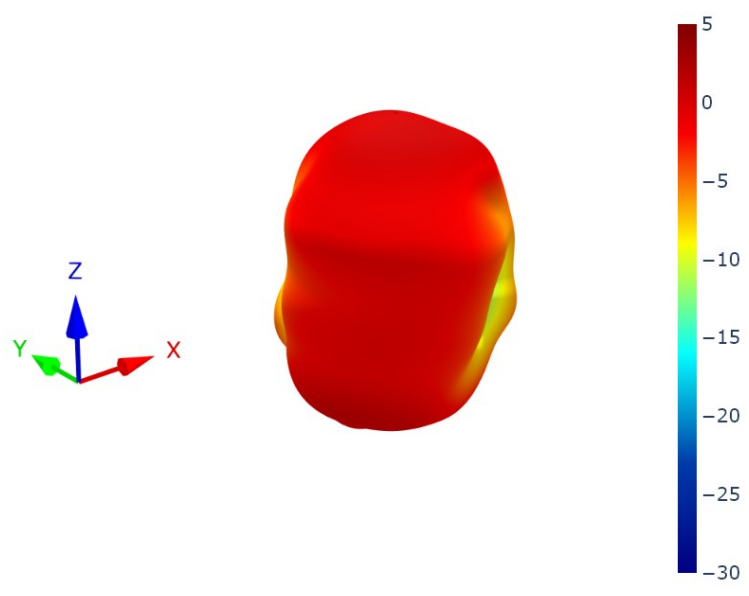

6.16 Cable Feed Straight Patterns at 1805 MHz

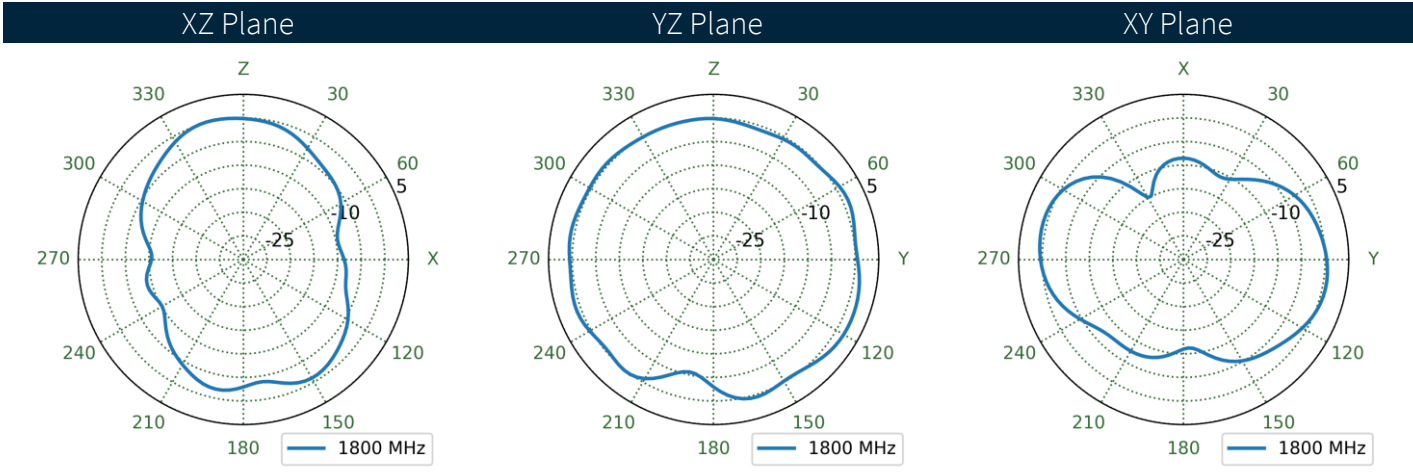
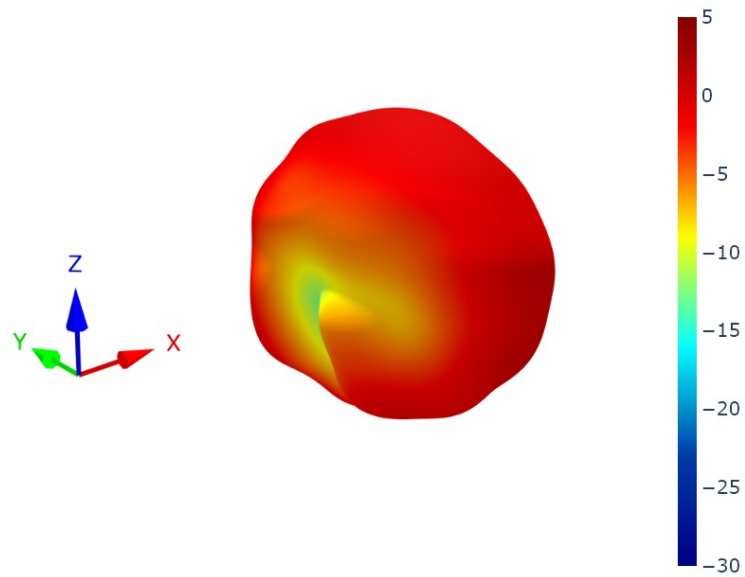

6.17 Cable Feed Left Patterns at 1920 MHz

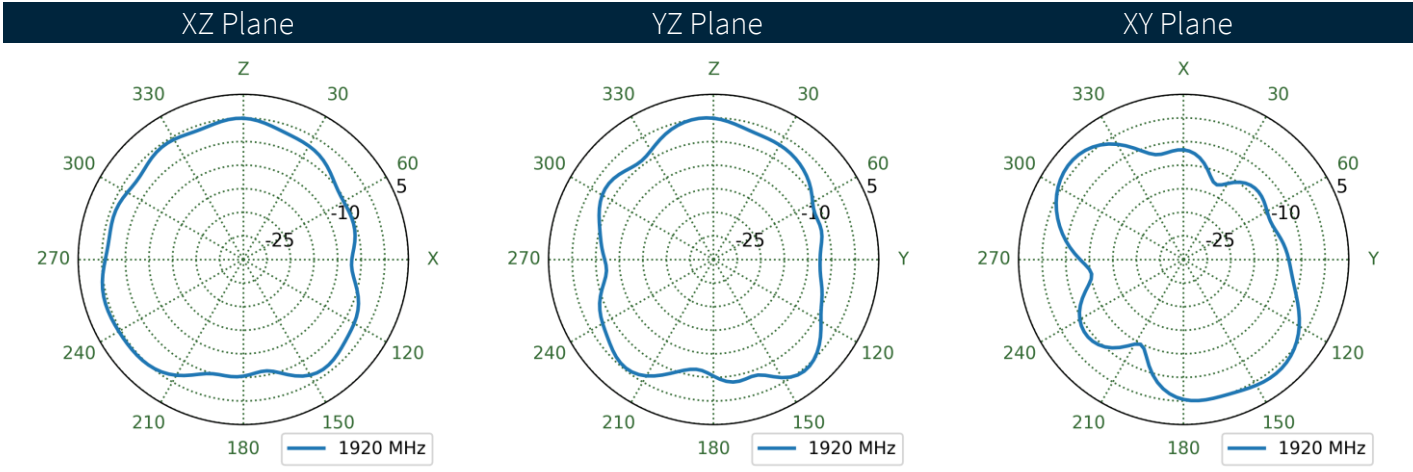
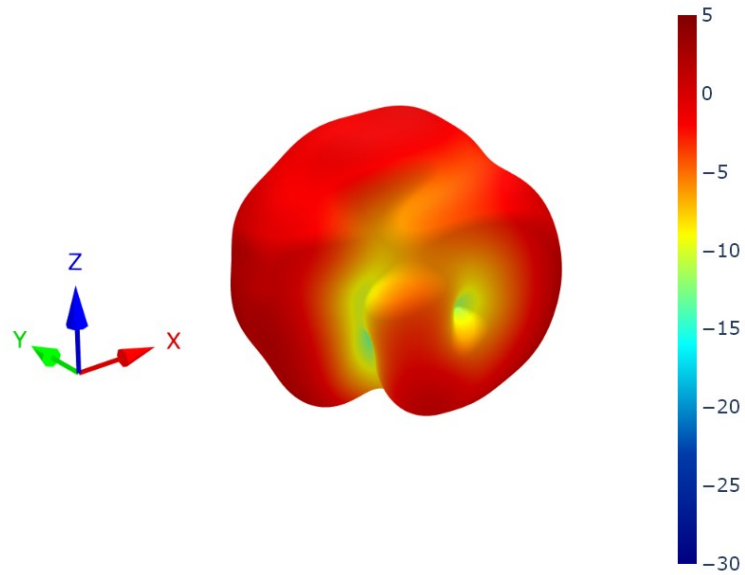

6.18 Cable Feed Right Patterns at 1920 MHz

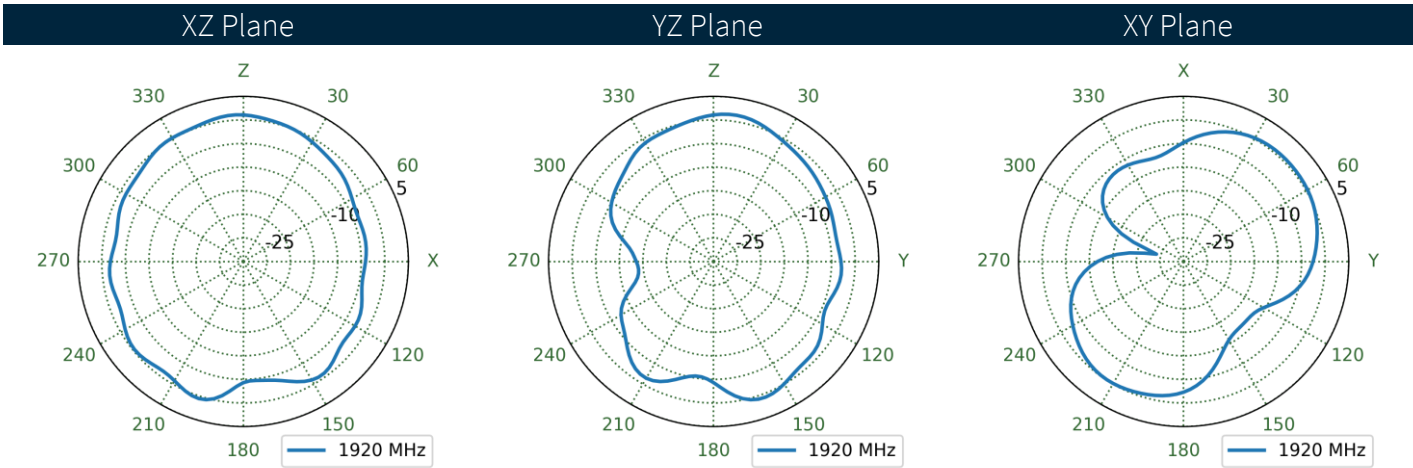
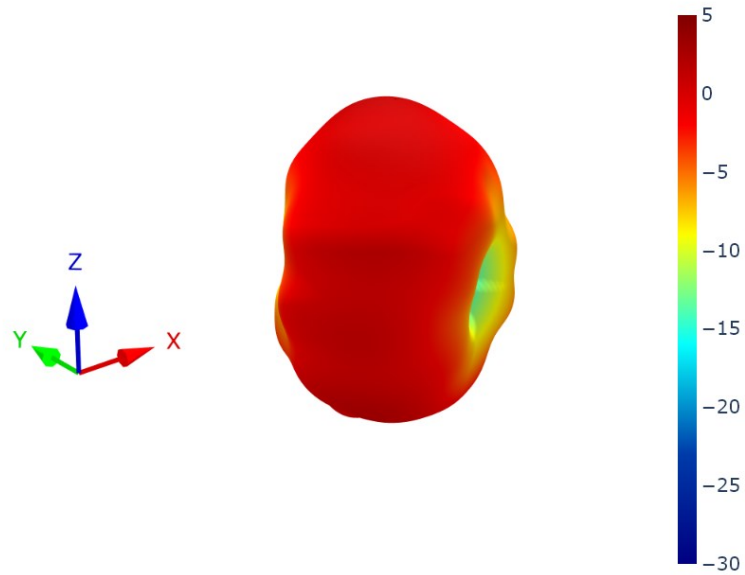

6.19 Cable Feed Straight Patterns at 1920 MHz

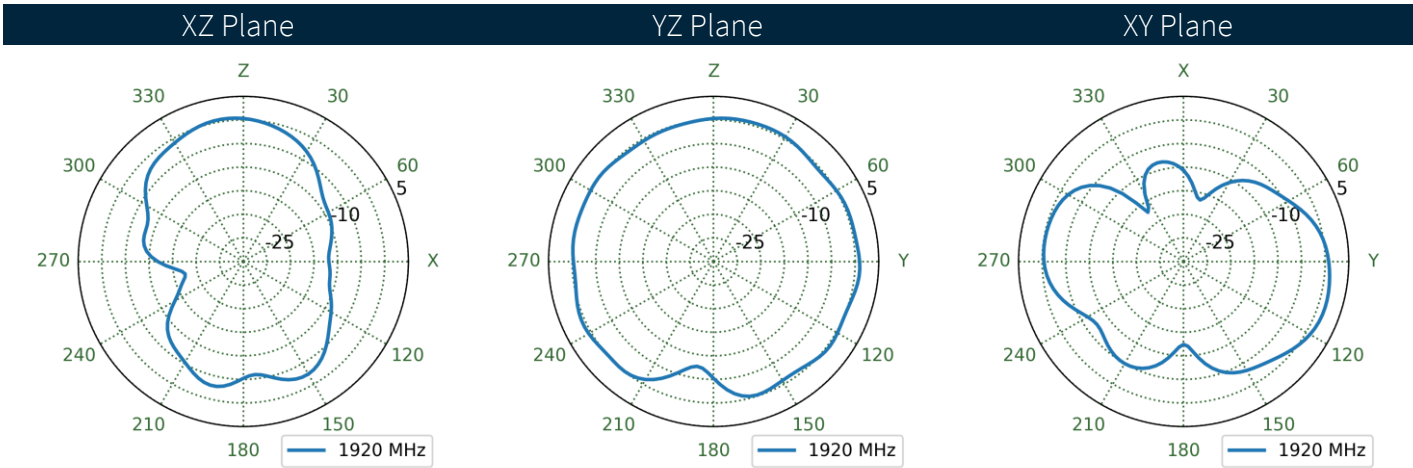
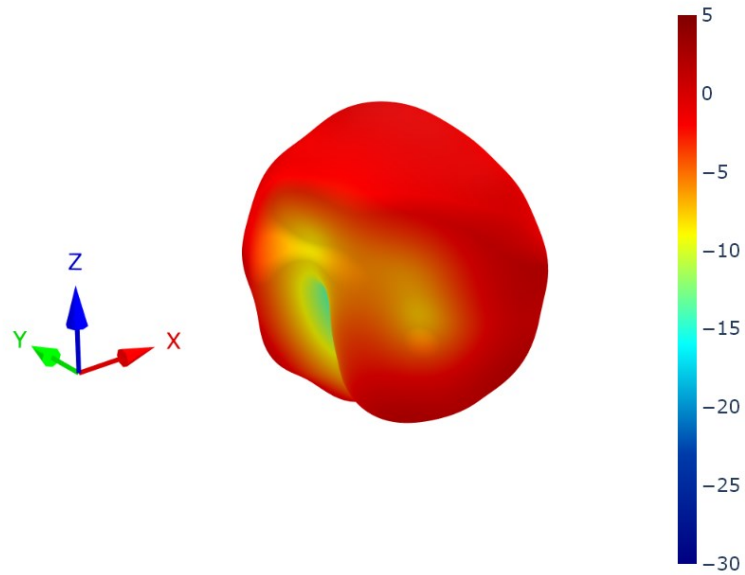

**6.20** Cable Feed Left Patterns at 1990 MHz

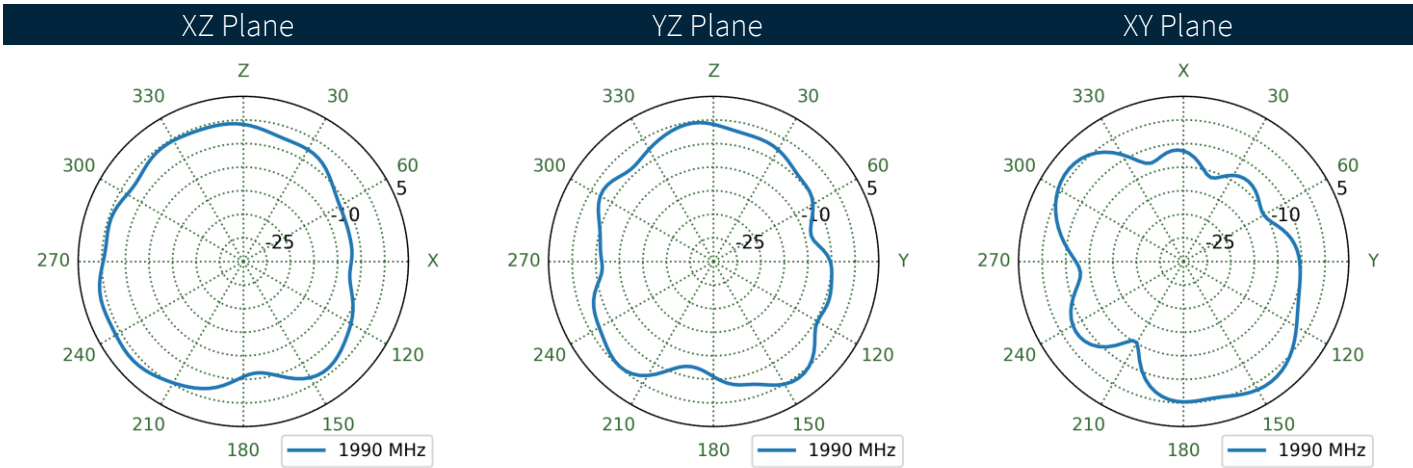
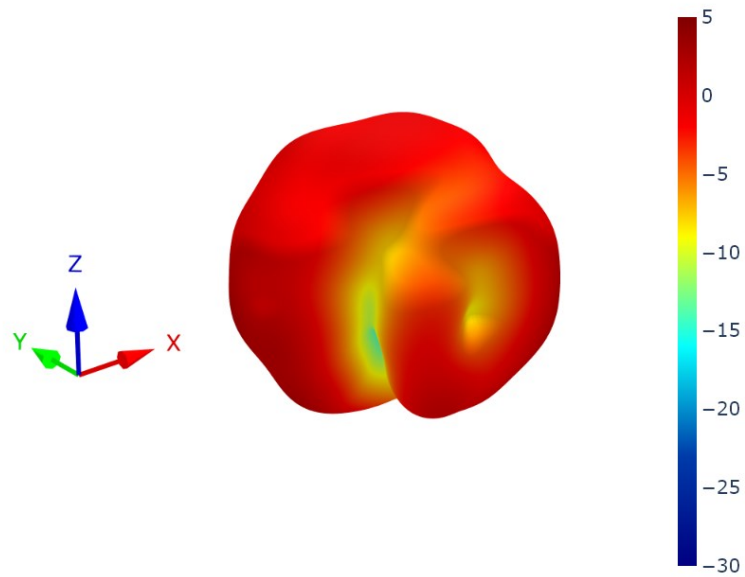



6.21 Cable Feed Right Patterns at 1990 MHz

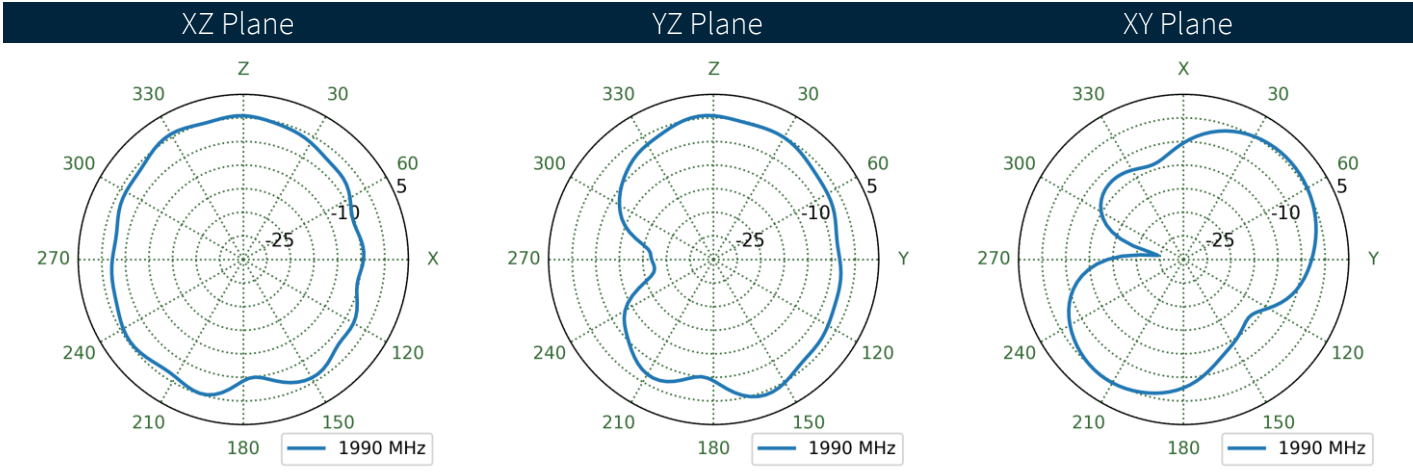
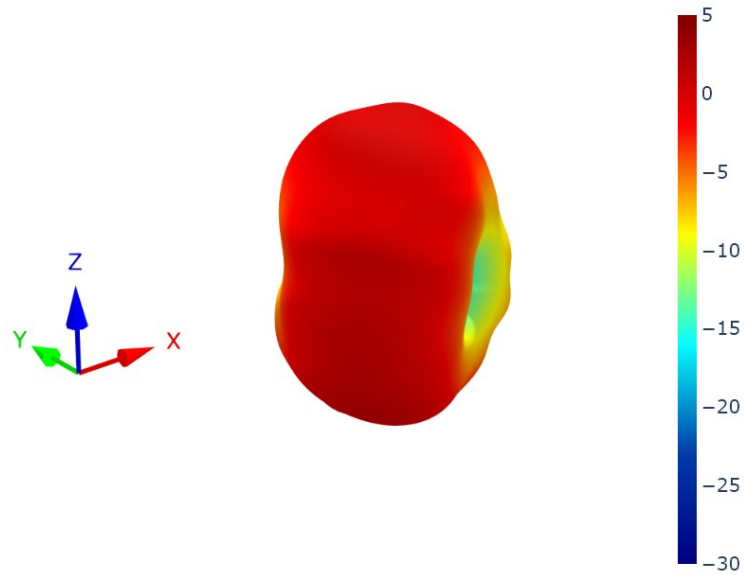

6.22 Cable Feed Straight Patterns at 1990 MHz

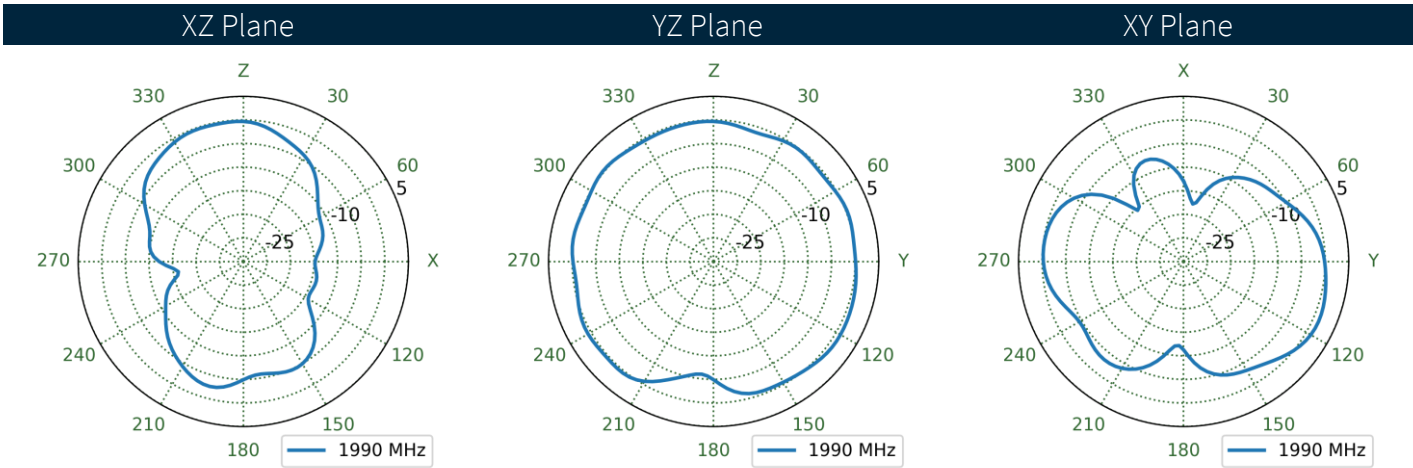
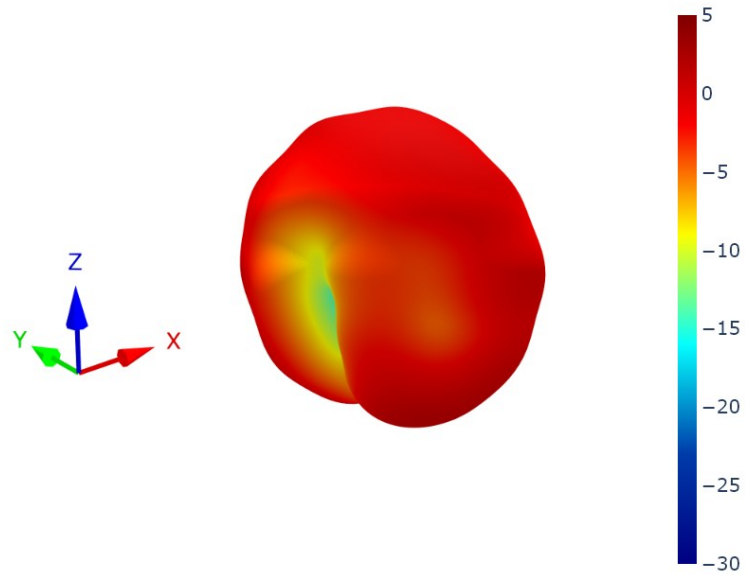

6.23 Cable Feed Left Patterns at 2360 MHz

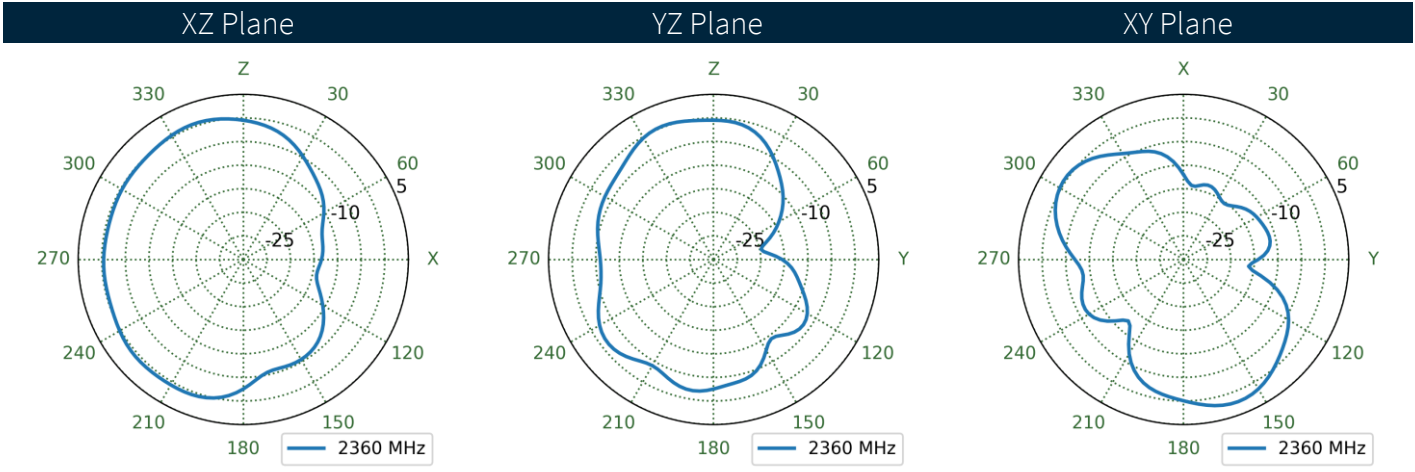
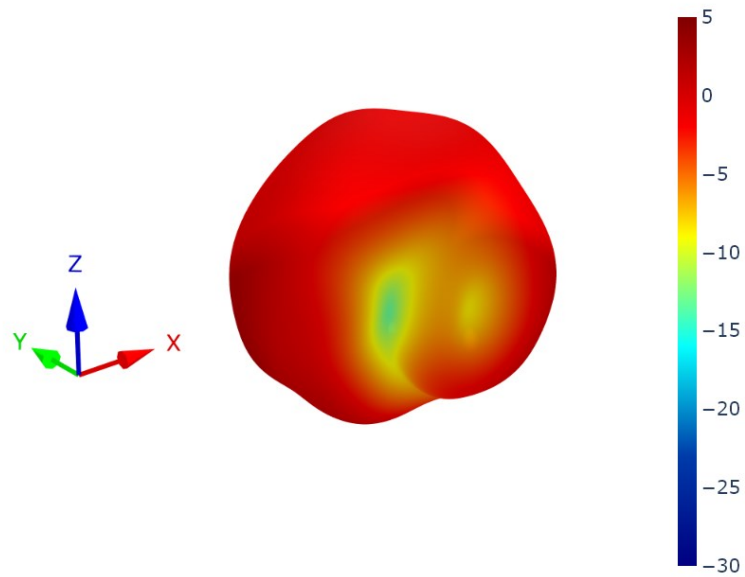

6.24 Cable Feed Right Patterns at 2360 MHz

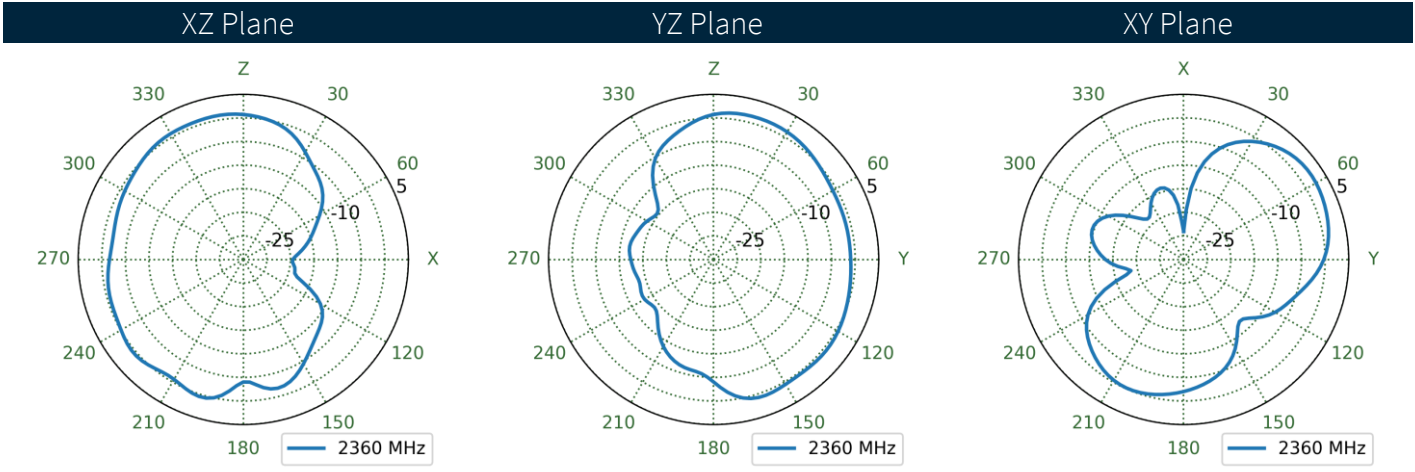
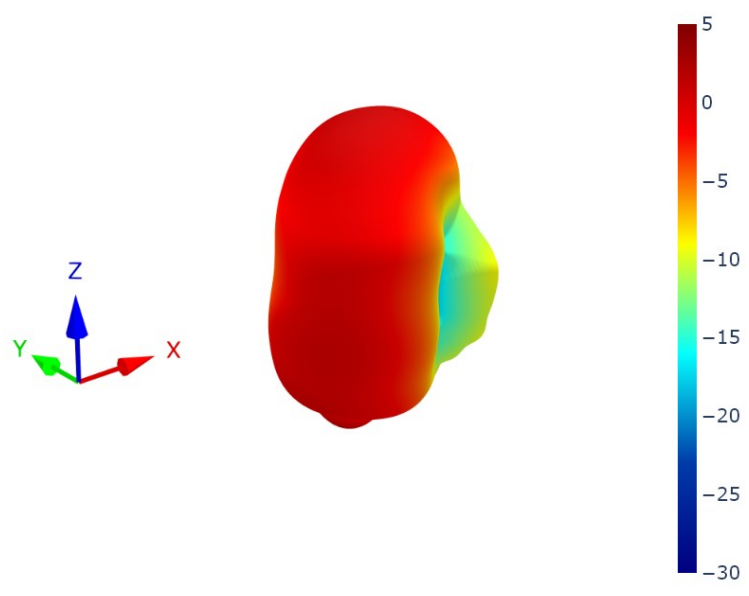

6.25 Cable Feed Straight Patterns at 2360 MHz

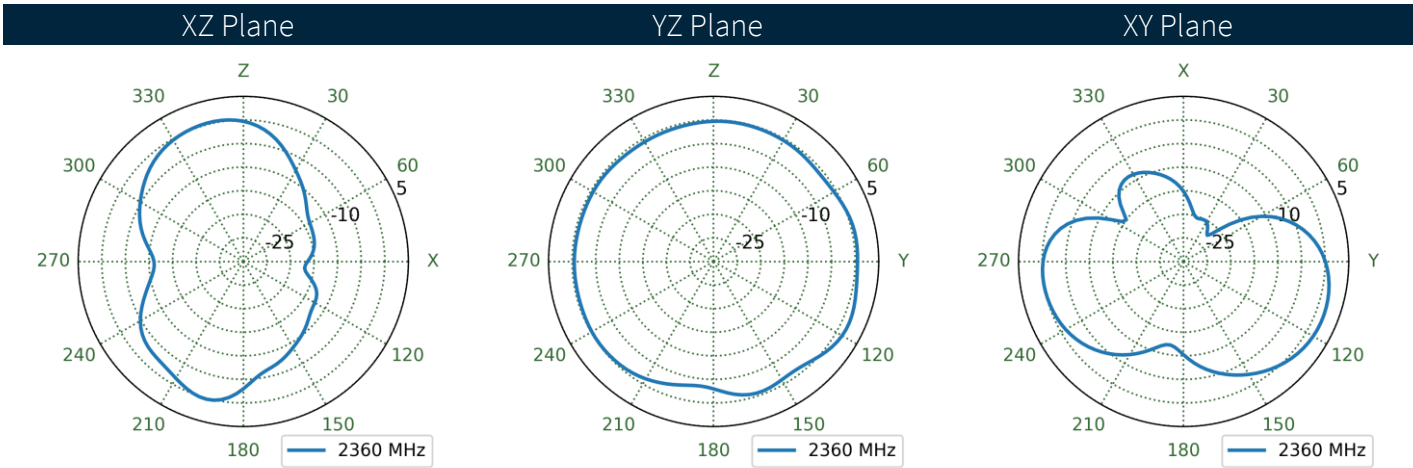
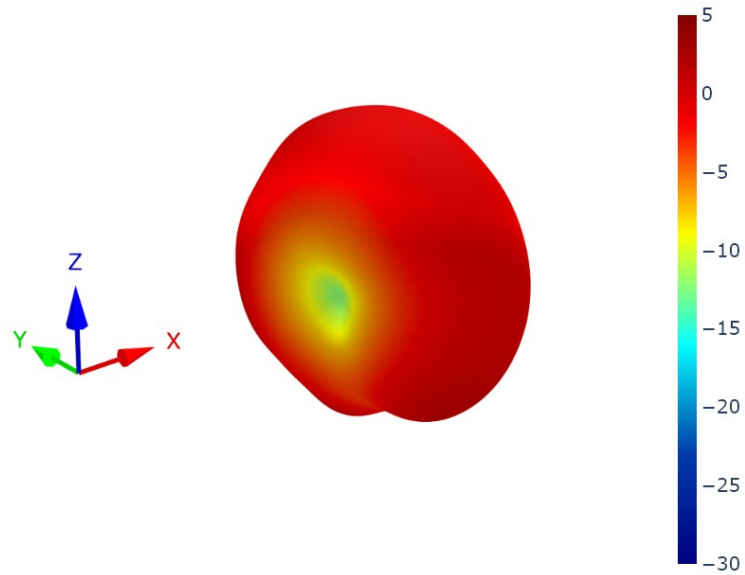

6.26 Cable Feed Left Patterns at 2595 MHz

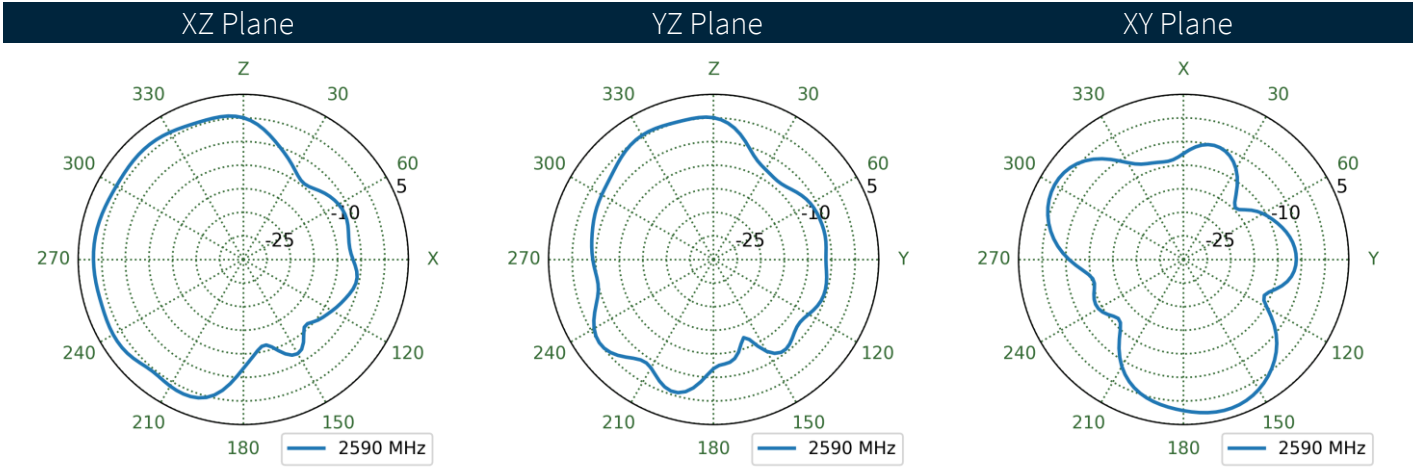
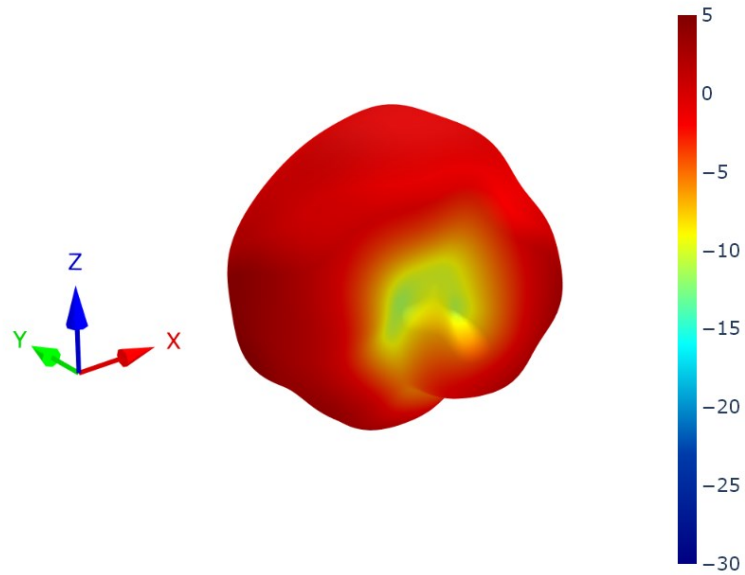

6.27 Cable Feed Right Patterns at 2595 MHz

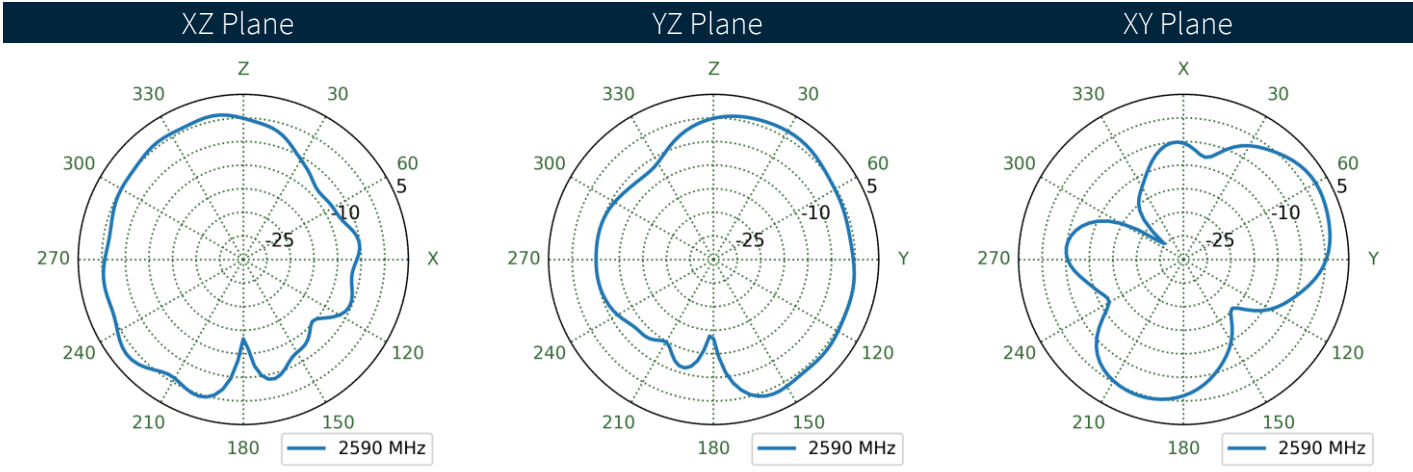
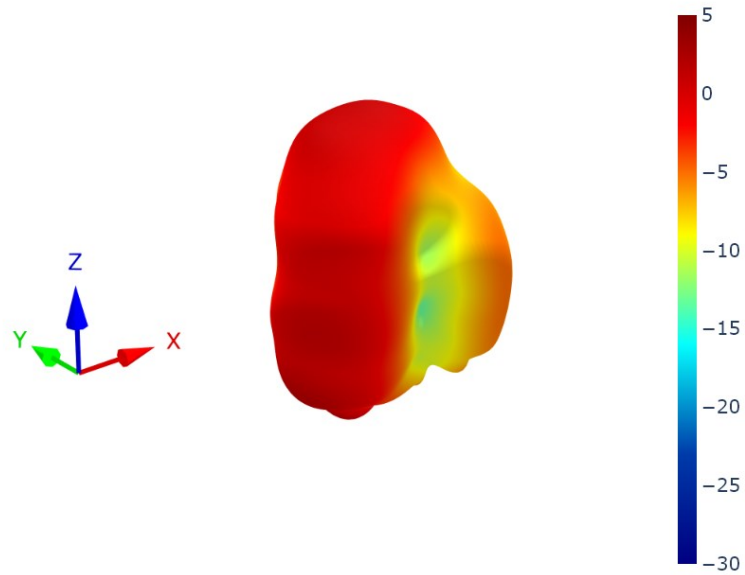

6.28 Cable Feed Straight Patterns at 2595 MHz

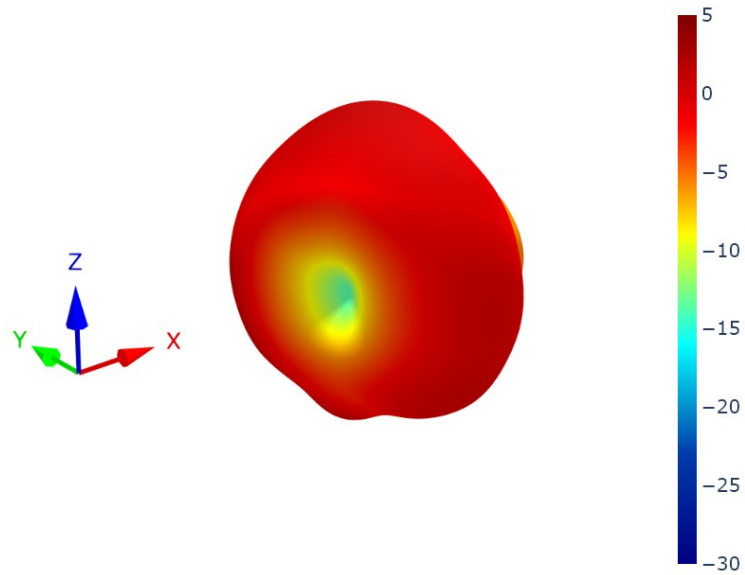

XZ Plane                      YZ Plane                      XY Plane

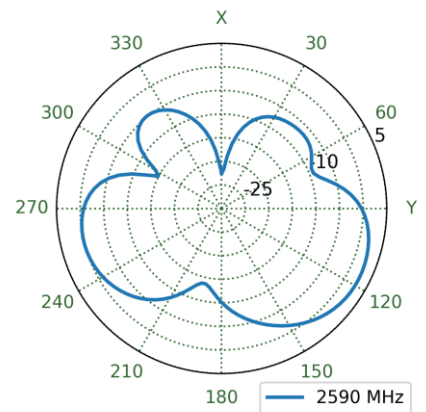
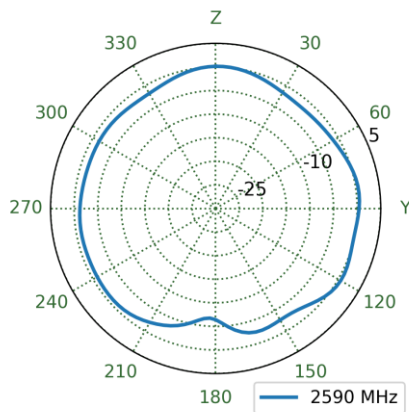
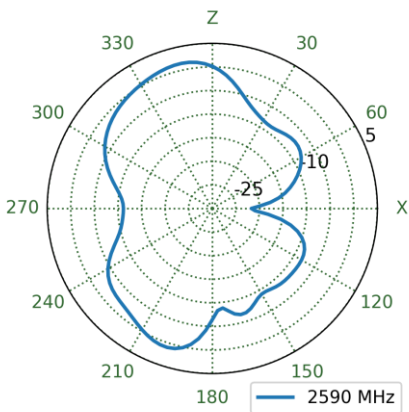



6.29 Cable Feed Left Patterns at 3550 MHz

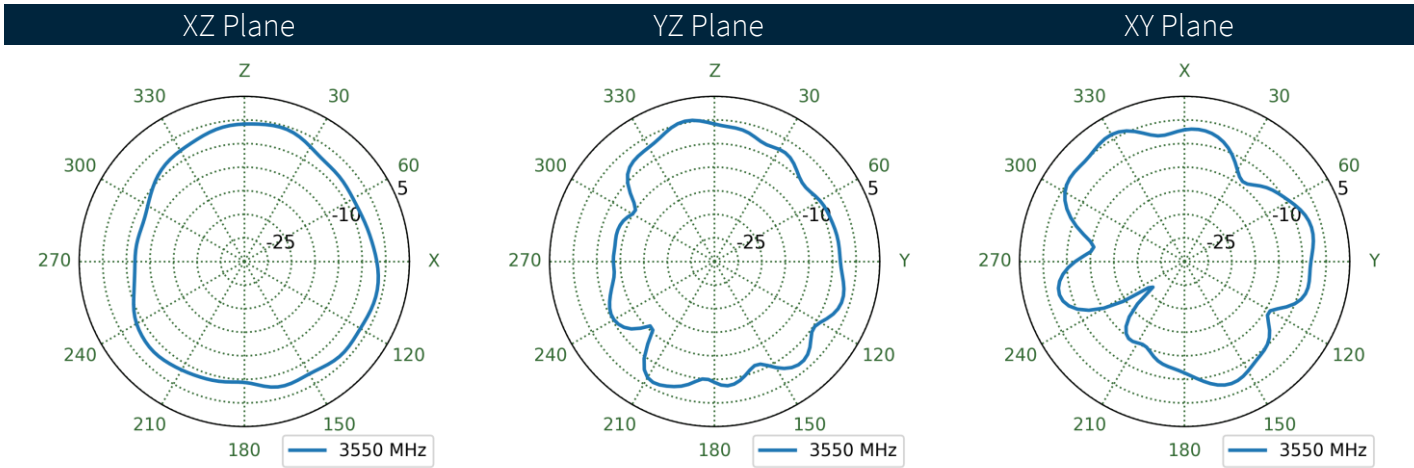
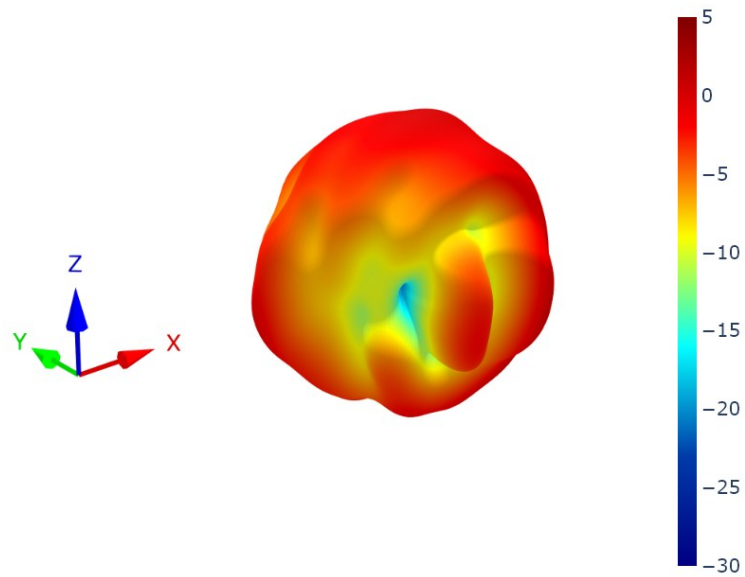

**6.30** Cable Feed Right Patterns at 3550 MHz

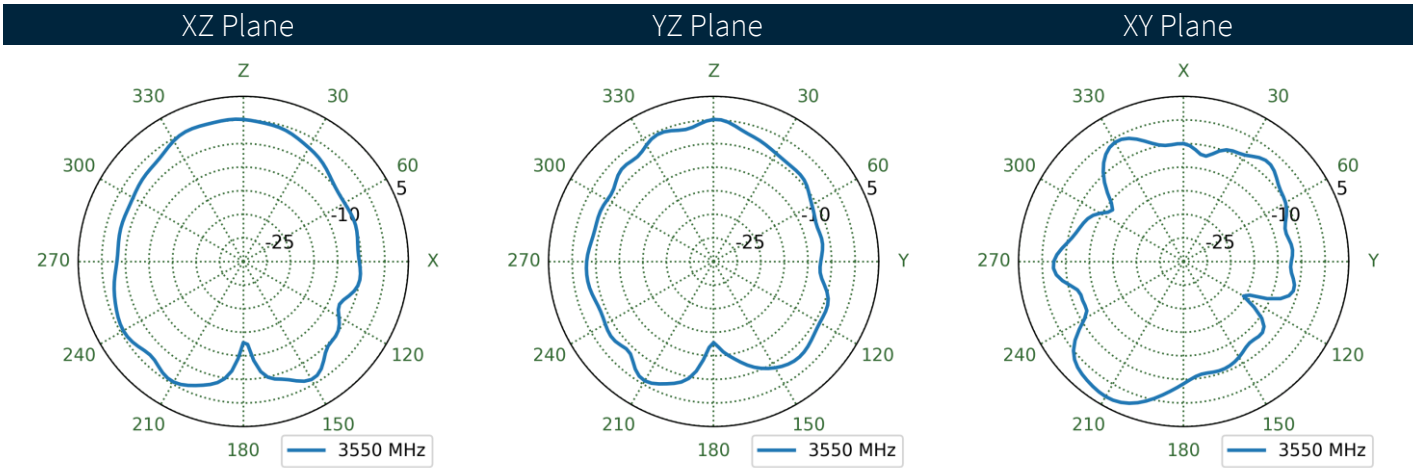
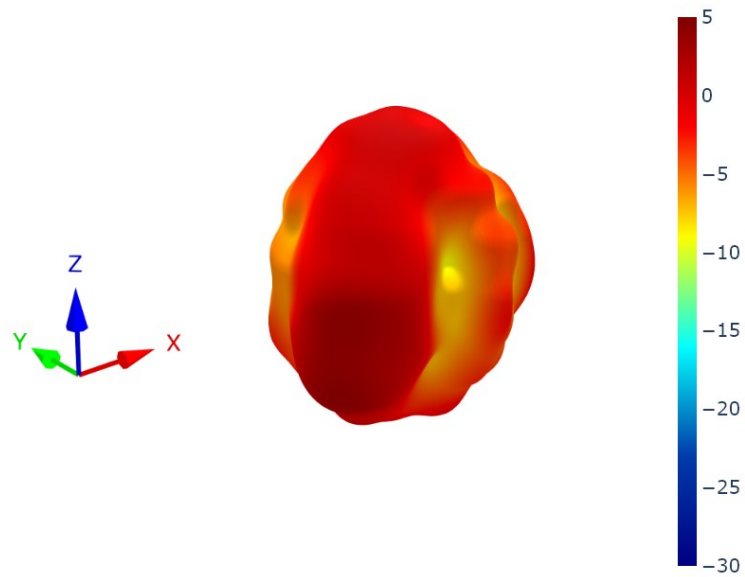

6.31 Cable Feed Straight Patterns at 3550 MHz

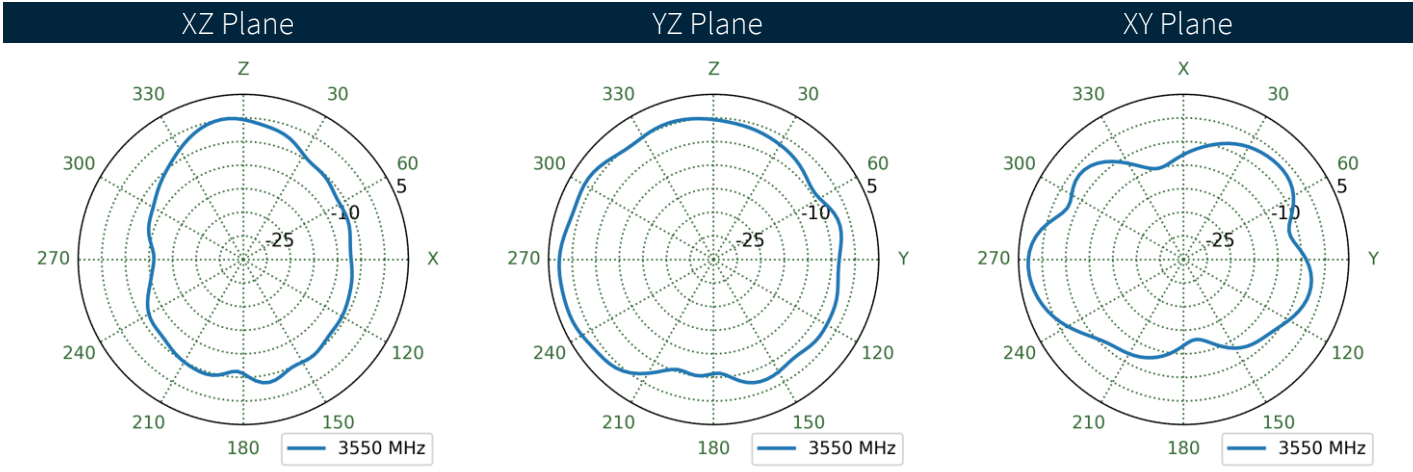
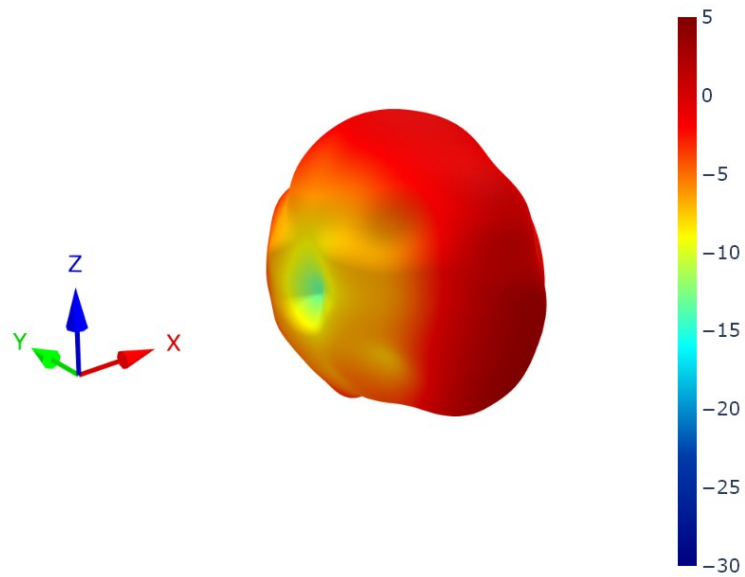

6.32 Cable Feed Left Patterns at 4600 MHz

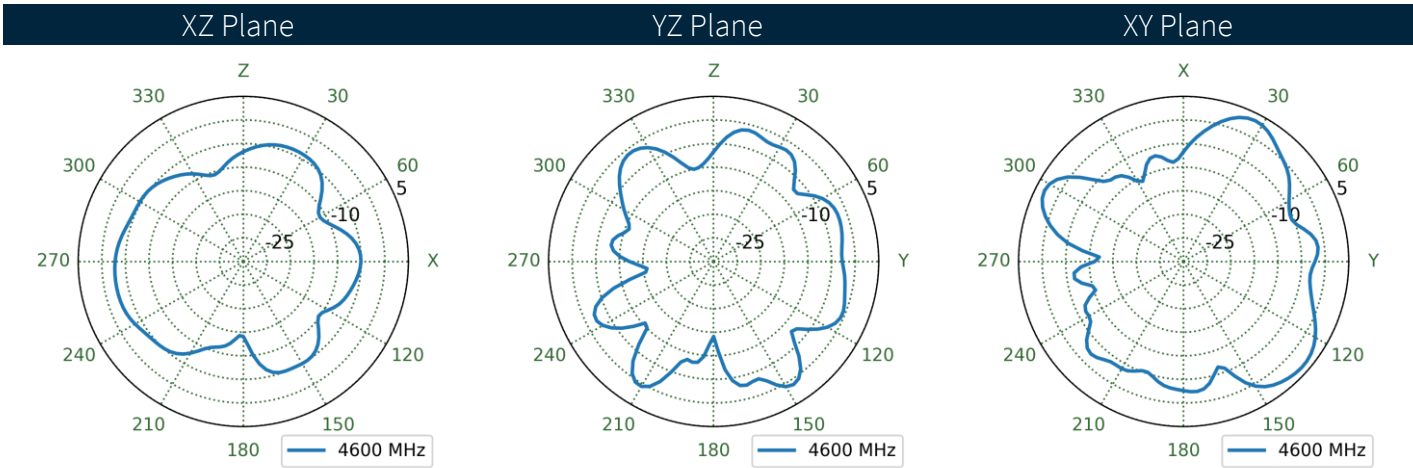
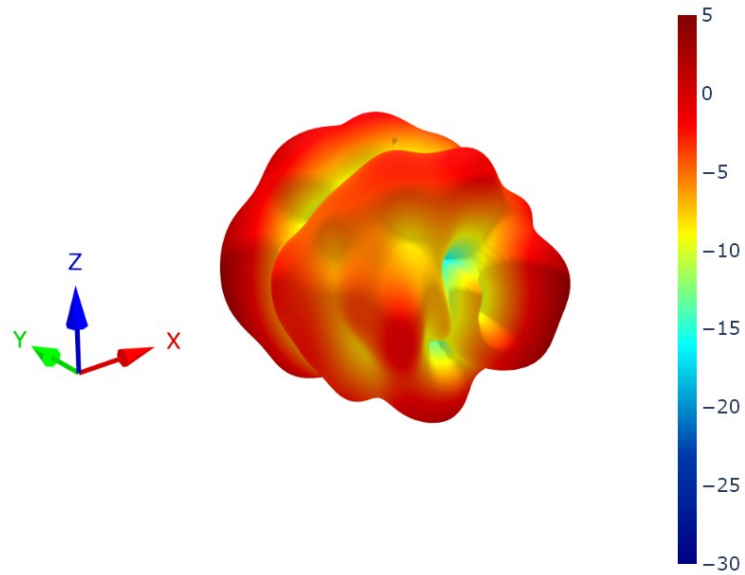

**6.33** Cable Feed Right Patterns at 4600 MHz

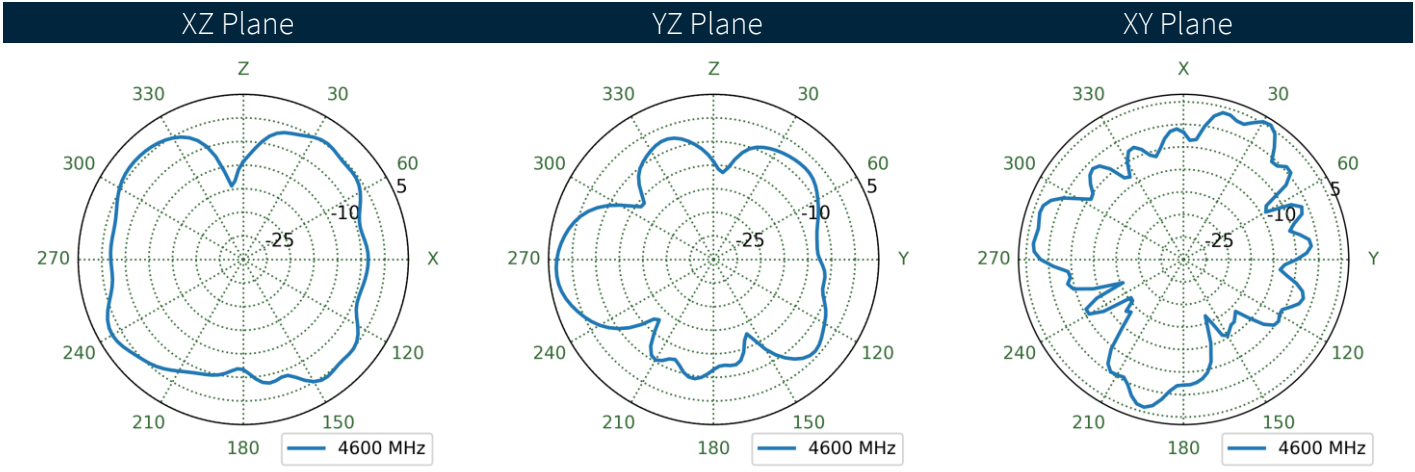
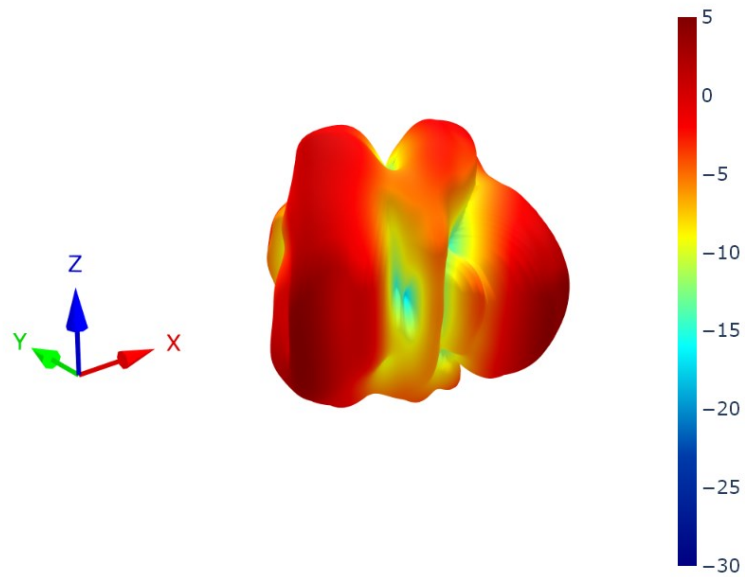

6.34 Cable Feed Straight Patterns at 4600 MHz

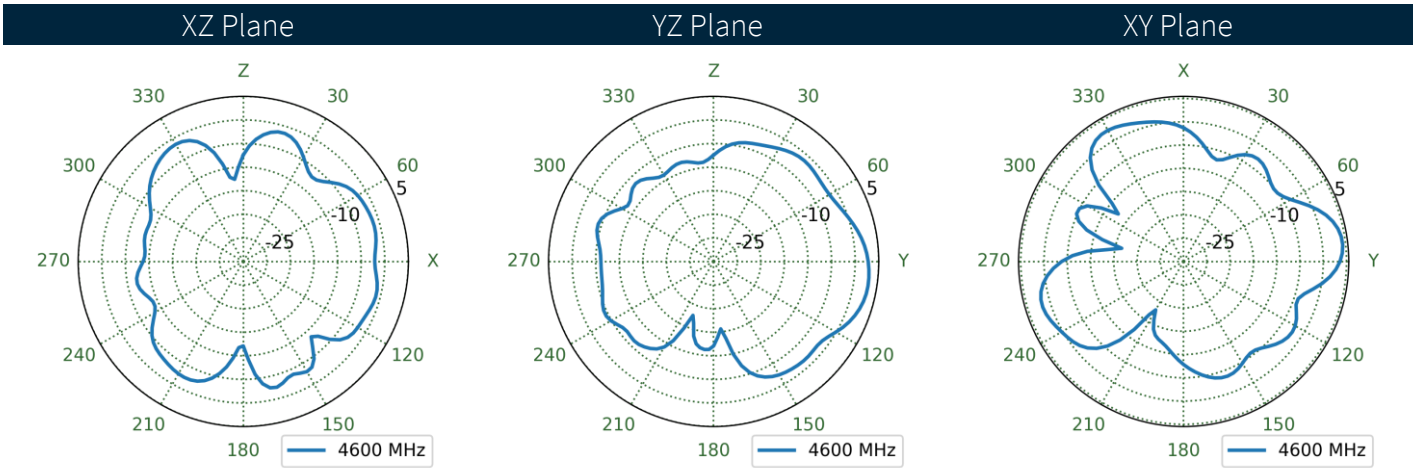
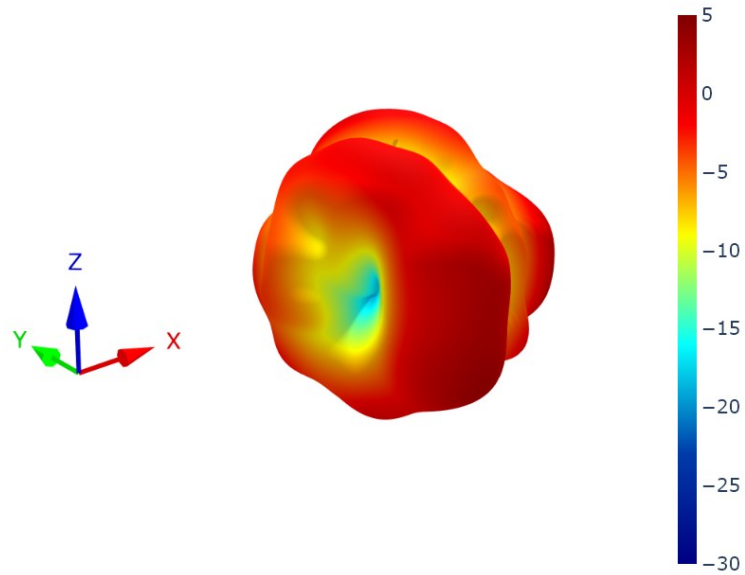

6.35 Cable Feed Left Patterns at 4800 MHz

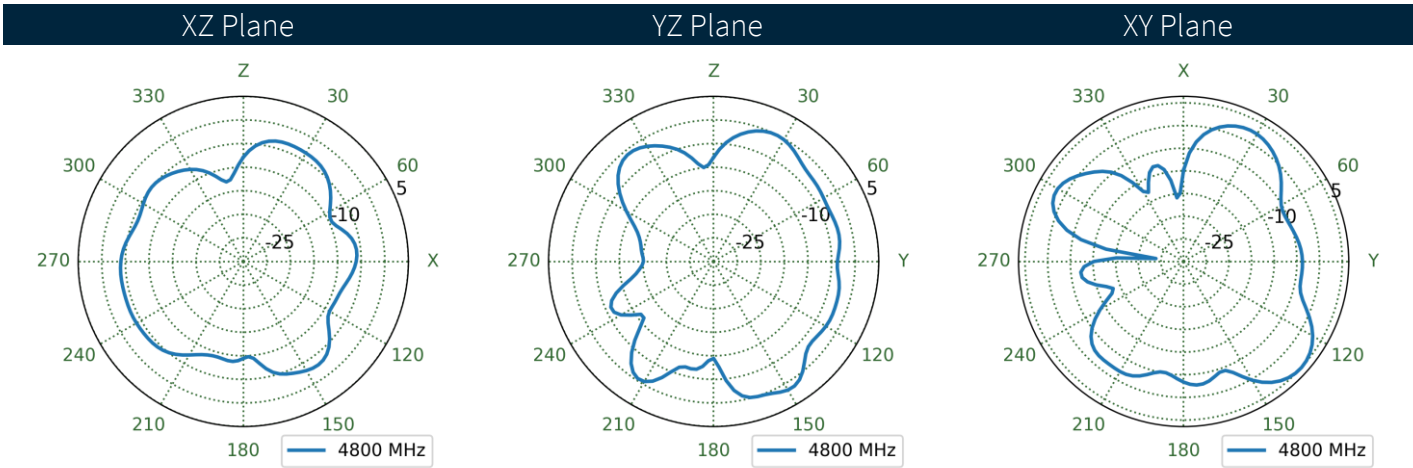
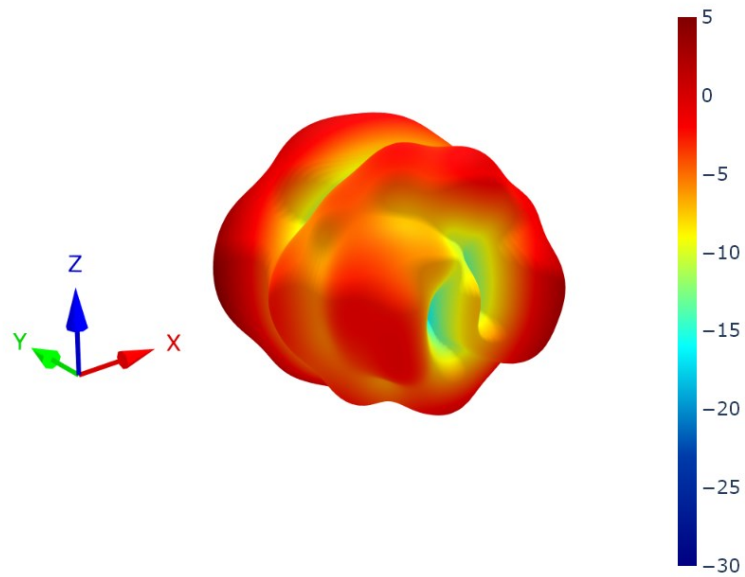

**6.36** Cable Feed Right Patterns at 4800 MHz

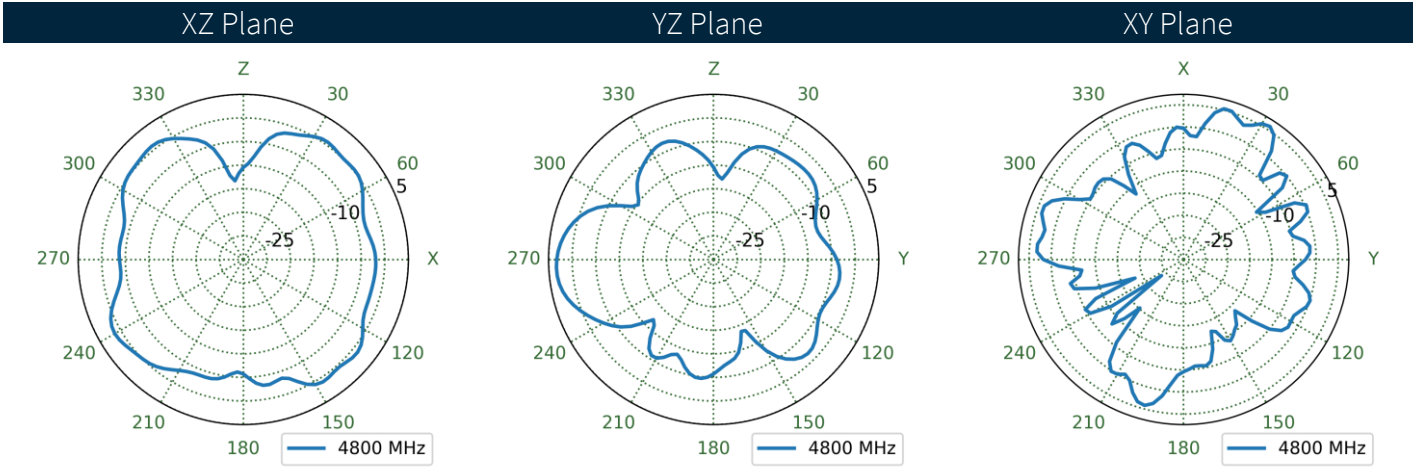
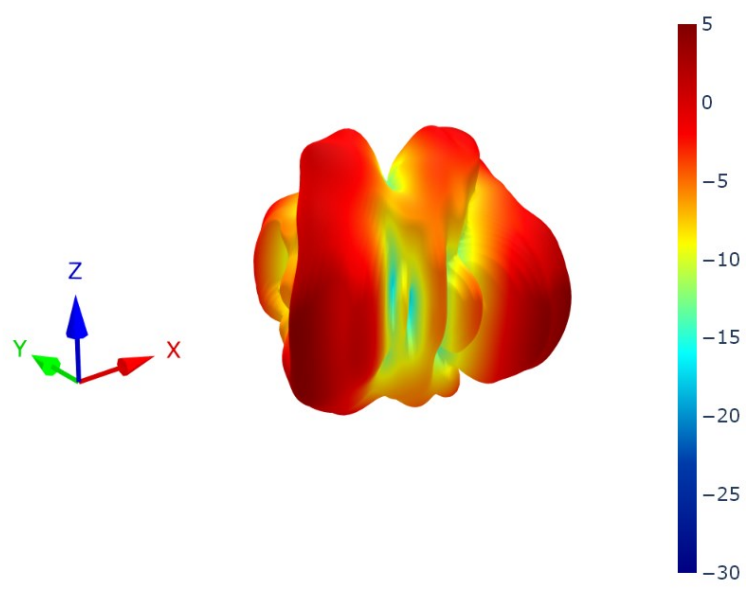



6.37 Cable Feed Straight Patterns at 4800 MHz

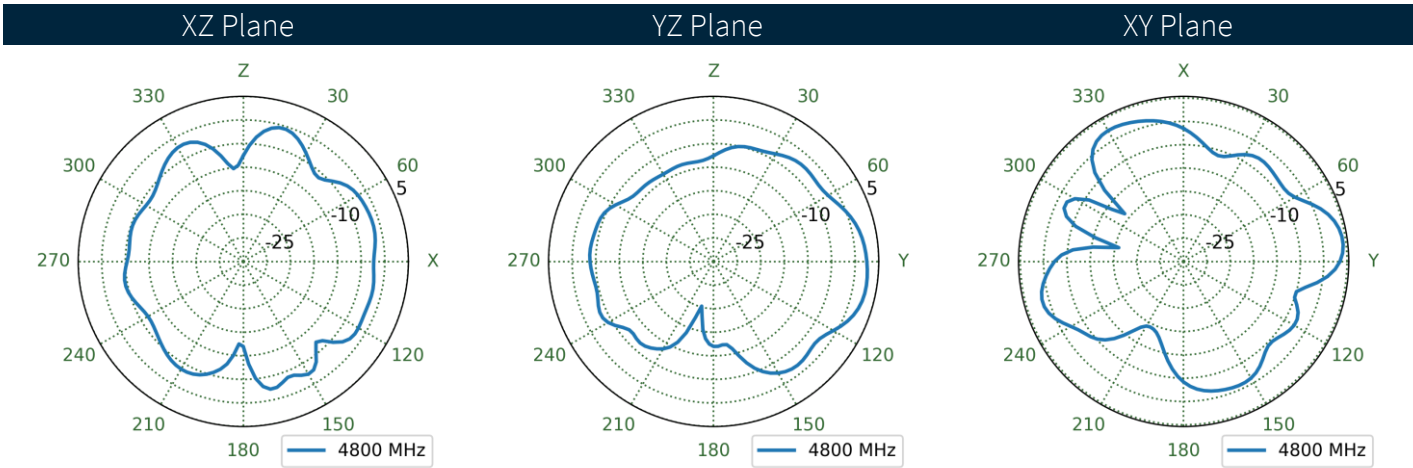
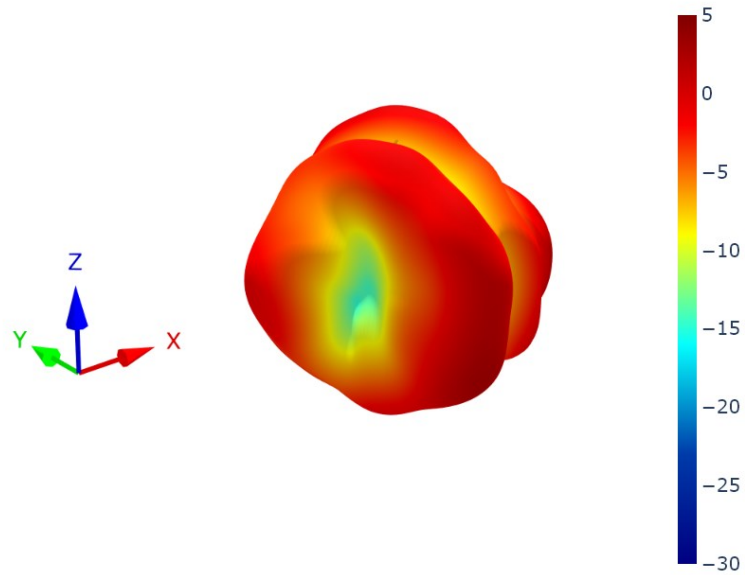

**6.38** Cable Feed Left Patterns at 5530 MHz

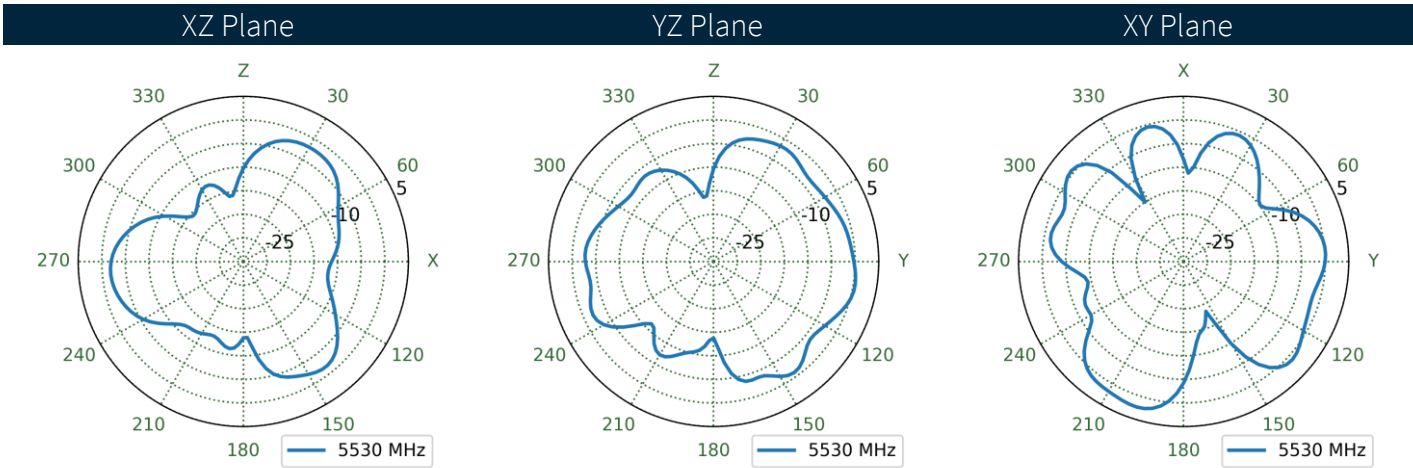
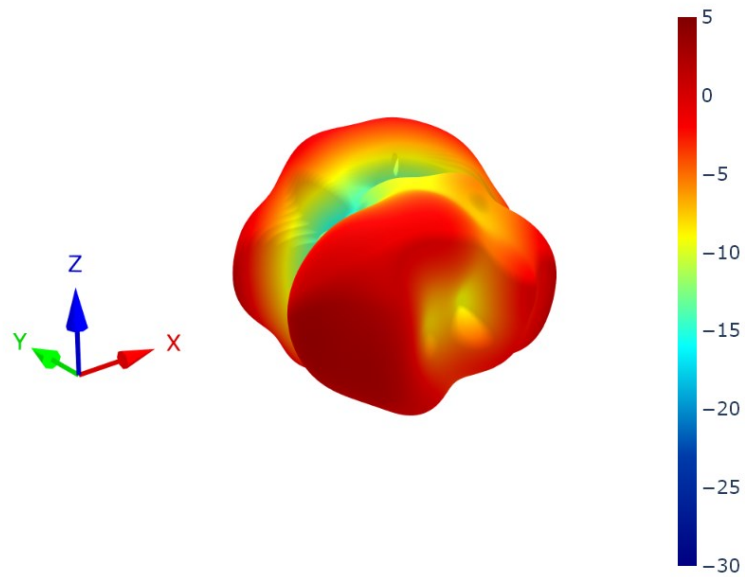

6.39 Cable Feed Right Patterns at 5530 MHz

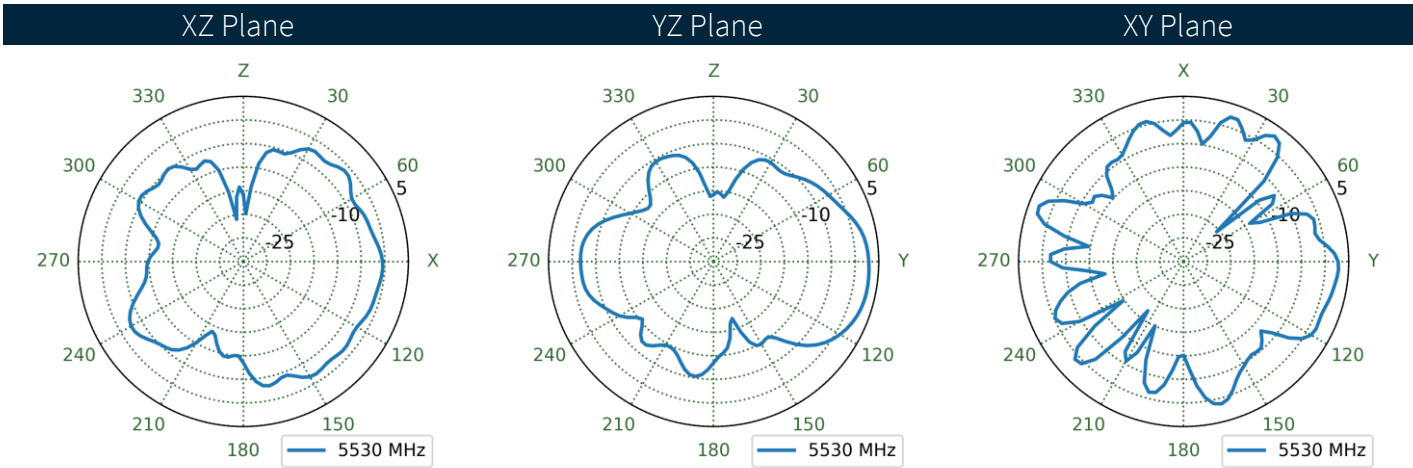
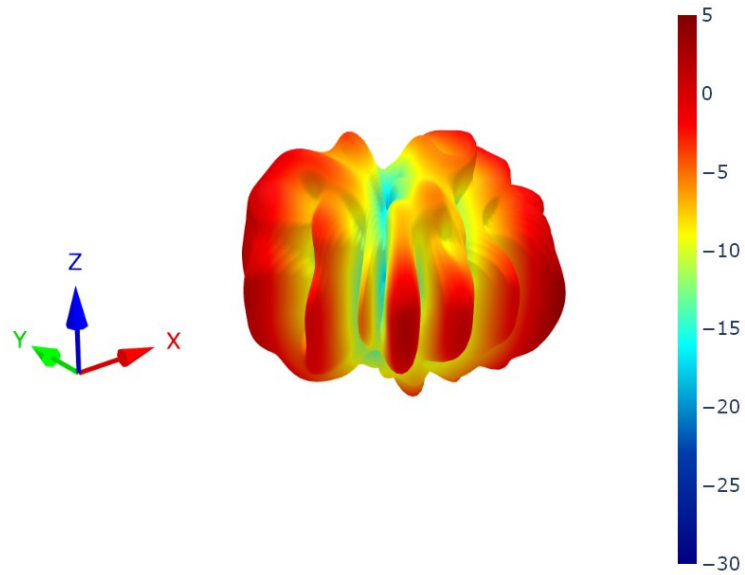

6.40 Cable Feed Straight Patterns at 5530 MHz

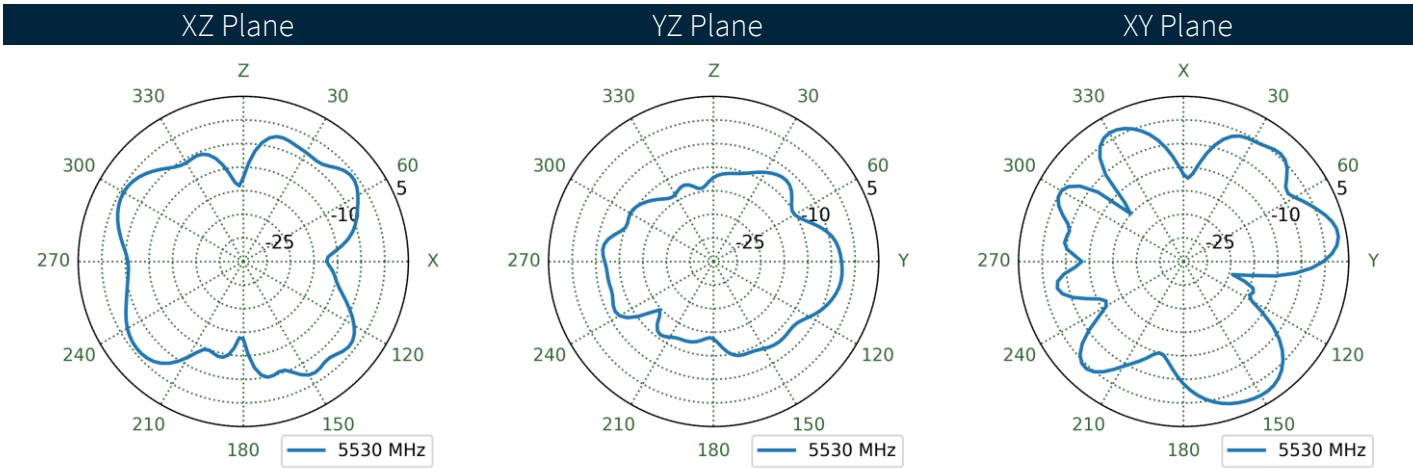
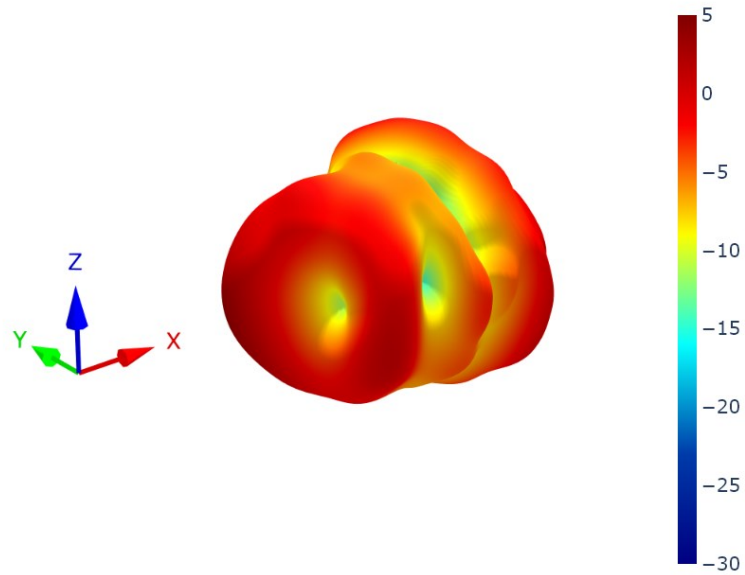

Changelog for the datasheet

**SPE-24-8-235 – FXUB16.07.0150AQ**

**Revision: A (Initial Release)**

Date:	2024-09-24
Notes:	Initial Datasheet Release
Author:	Gary West

**Previous Revisions**



[www.taoglas.com](http://www.taoglas.com)

