



TAOGLAS®



Datasheet

Part No:
FXUB53.07.150C

Description

Super Small, Wide Band Flex Antenna 600MHz – 6GHz

Features:

- Flexible Wideband Antenna
- Covers worldwide 5G/4G Bands
- Connector: I-PEX MHFI (U.FL Compatible)
- Cable: 150mm 1.37 Coaxial
- Dimensions: 120 x 20 x 0.24mm
- RoHS & Reach Compliant

1.	Introduction	3
2.	Specification	4
3.	Mechanical Drawing	6
4.	Packaging	7
5.	Antenna Characteristics	8
6.	Radiation Patterns	12
7.	Application Note	52
<hr/>		
	Changelog	60

Taoglas makes no warranties based on the accuracy or completeness of the contents of this document and reserves the right to make changes to specifications and product descriptions at any time without notice. Taoglas reserves all rights to this document and the information contained herein. Reproduction, use or disclosure to third parties without express permission is strictly prohibited.



1. Introduction



Super Small, High-performance Wideband Cellular Antenna

The Taoglas FXUB53 flexible wideband antenna has been designed to cover all working frequencies in the 600-6000 MHz spectrum. It is engineered to cover all 5G/4G cellular bands (with fallback to 3G/2G), NB-IoT, Cat-M, Wi-Fi, and ISM bands. With its super small footprint of 120x20mm, it alleviates size constraint issues commonly seen when integrating a high-performance antenna into compact IoT devices. It has been designed to be mounted directly onto a plastic enclosures or glass.

When used in-device, the radiated power and sensitivity improves substantially, and enables the highest throughput rate, essential for today's broadband devices. The antenna is delivered on a flexible PCB with exceptional efficiencies on all bands for antenna of this size. It is ground-plane independent, with a cable and connector for easy installation. It is made of durable flexible polymer, with efficiencies of up to 70% across all cellular bands. At 120 x 20 x 0.2mm, the antenna has a small footprint and is ultra-thin. It is installed in devices by a simple "peel and stick" process, attaching securely to non-metal surfaces via 3M adhesive. It enables designers to use only one antenna that covers all frequencies and future proofs device design for 5G and 4G globally. It is also the ideal antenna to fit in devices that are being retrofitted with wireless functionality, as it will cover non cellular applications such as 868, 915MHz or Zigbee applications. The wide bandwidth is more resistant to detuning than traditional small but narrow-band legacy antennas.

Typical Applications Include:

- IoT and Connected Devices
- UAVs and Autonomous Vehicles
- Industrial Robotics and Automation

The antenna has a unique hybrid design. Within one antenna structure the electromagnetic waves travel in two predominant propagation modes- one for lower frequencies, e.g. 600 MHz, and the other for higher 5G/4G and Wi-Fi frequencies up to 6GHz. It is an ideal choice for any device maker that needs to keep manufacturing costs down over the lifetime of a product, as the same antenna can be used if the radio module is upgraded to include additional frequency bands.

Cables and Connectors are fully customizable, subject to MOQ, for further information please contact your regional Taoglas Customer support team.

2. Specification

LTE Electrical									
Band	Frequency (MHz)	Measurement	Efficiency (%)	Average Gain (dB)	Peak Gain (dBi)	Impedance	Polarization	Radiation Pattern	Max. input power
5G NR/4G Band 71	617-698	Cable Feed Left	24.7	-6.08	-0.73	50 Ω	Linear	Omni	2W
		Cable Feed Right	39.2	-4.06	1.28				
		Cable Feed Straight	32.3	-4.91	-0.17				
4G/3G Band 12,13,14,17,28,29	698-824	Cable Feed Left	61.5	-2.11	2.81				
		Cable Feed Right	66.4	-1.78	2.29				
		Cable Feed Straight	65.2	-1.86	1.93				
4G/3G/NB-IoT/Cat M Band 5,8,18,19,20,26,27	824-960	Cable Feed Left	60.7	-2.17	2.54				
		Cable Feed Right	57.3	-2.42	1.80				
		Cable Feed Straight	60.7	-2.17	1.82				
5G NR/4G Band 21,32,74,75,76	1427-1518	Cable Feed Left	72.5	-1.40	2.73				
		Cable Feed Right	65.3	-1.85	2.75				
		Cable Feed Straight	70.1	-1.54	3.24				
4G/3G Band 1,2,3,4,9,23,25,35,39,66	1710-2200	Cable Feed Left	68.1	-1.67	4.23				
		Cable Feed Right	69.9	-1.56	3.47				
		Cable Feed Straight	70.2	-1.54	3.88				
4G/3G Band 7,30,38,40,41	2300-2690	Cable Feed Left	64.8	-1.89	4.89				
		Cable Feed Right	62.9	-2.01	3.86				
		Cable Feed Straight	64.1	-1.93	3.77				
5G NR/4G Band 22,42,48,77,78,79	3300-5000	Cable Feed Left	65.6	-1.83	7.18				
		Cable Feed Right	65.4	-1.85	6.34				
		Cable Feed Straight	67.0	-1.74	6.69				
LTE5200/Wi-Fi5800	5150-5925	Cable Feed Left	55.6	-2.55	6.12				
		Cable Feed Right	56.4	-2.49	5.80				
		Cable Feed Straight	58.0	-2.37	6.02				

Mechanical

Dimensions	120 x 20 x 0.24mm
Weight	1.7g
Material	Flexible Polymer
Connector	I-PEX MHFI (U.FL Compatible)
Cable	150mm of 1.37 Co-axial

Environmental

Temperature Range	-40°C to 85°C
Relative Humidity	40% to 95%
RoHs & REACH Compliant	Yes

3. Mechanical Drawing

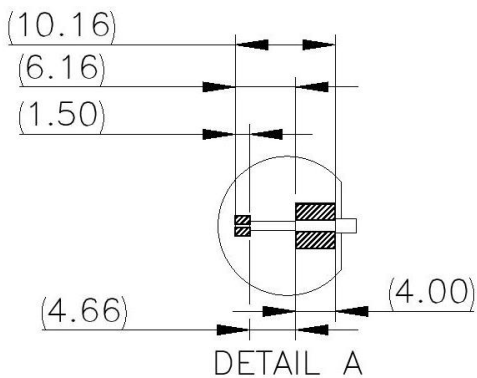
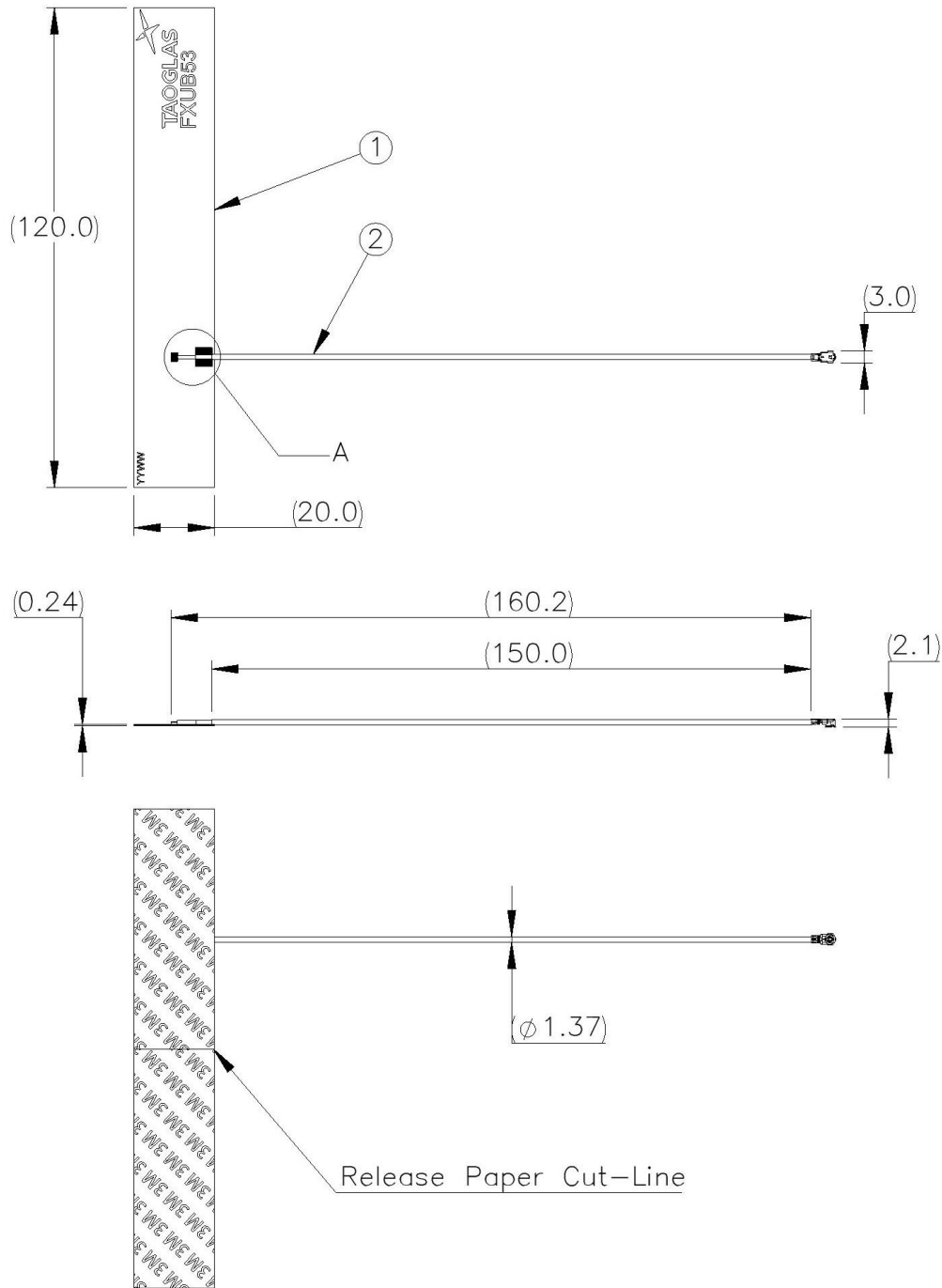

ITEM NO.	DESCRIPTION	Color	QTY.
1	Wide Band Flex Antenna 600MHz to 6GHz	Black	1
2	IPEX MHF 1 (U.FL Comp) 1.37,150MM,Open/Strip/Tin 1.5/4.66/4	Cable: Black, Connector: Golden	1

4. Packaging

100pcs FXUB53.07.150.C per PE Bag
 Dimensions 200 x 320mm
 Weight -178g



2000pcs FXUB53.07.150.C per Carton
 Dimensions 360 x 310 x 160mm
 Weight – 3.96Kg



5. Antenna Characteristics

5.1 Test Setup

AUT



Vector Network Analyzer

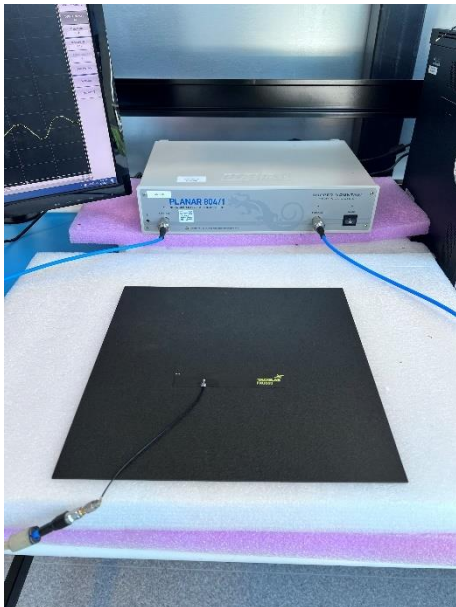

Cable Feed Left

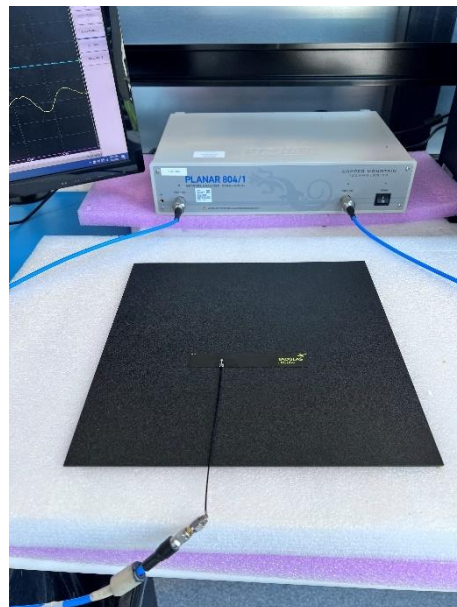

Cable Feed Straight

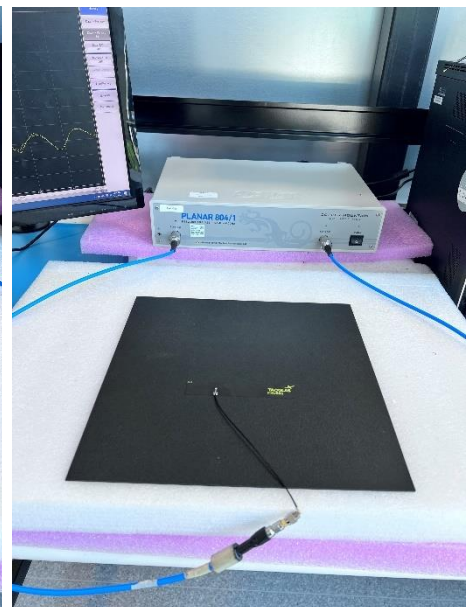

Cable Feed Right

5.2 Return Loss

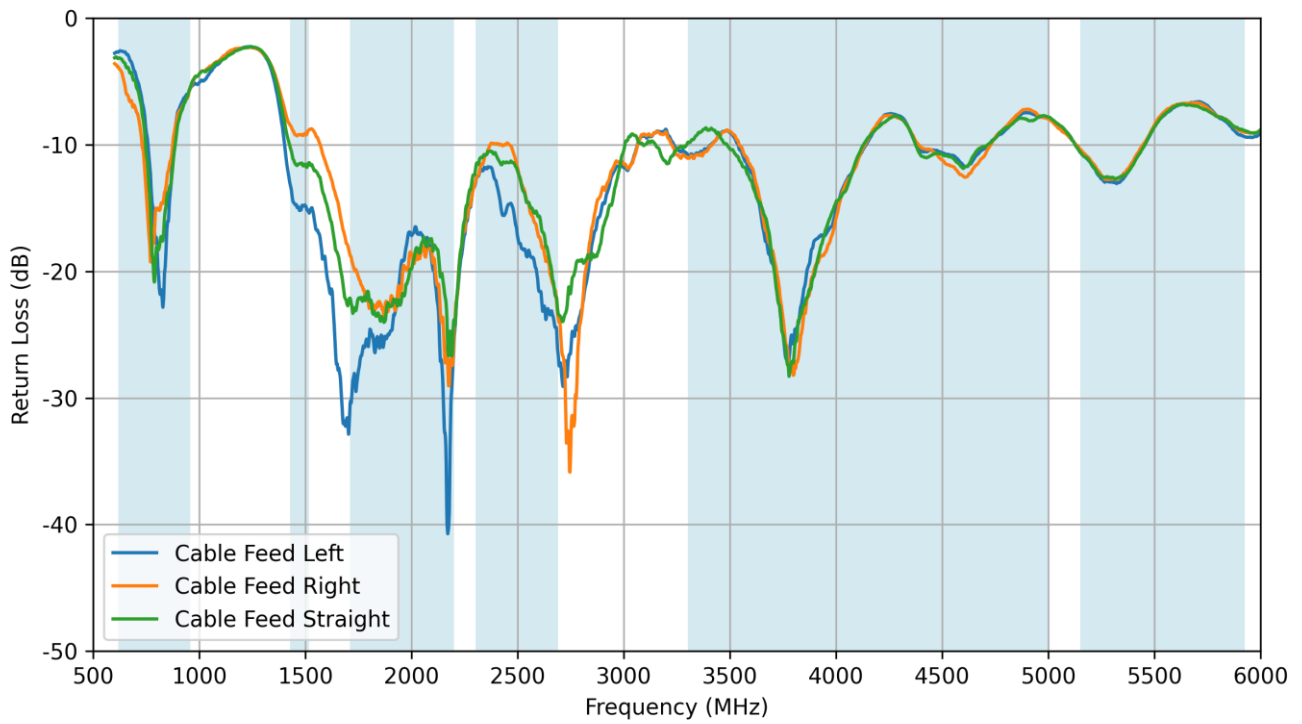

5.3 VSWR

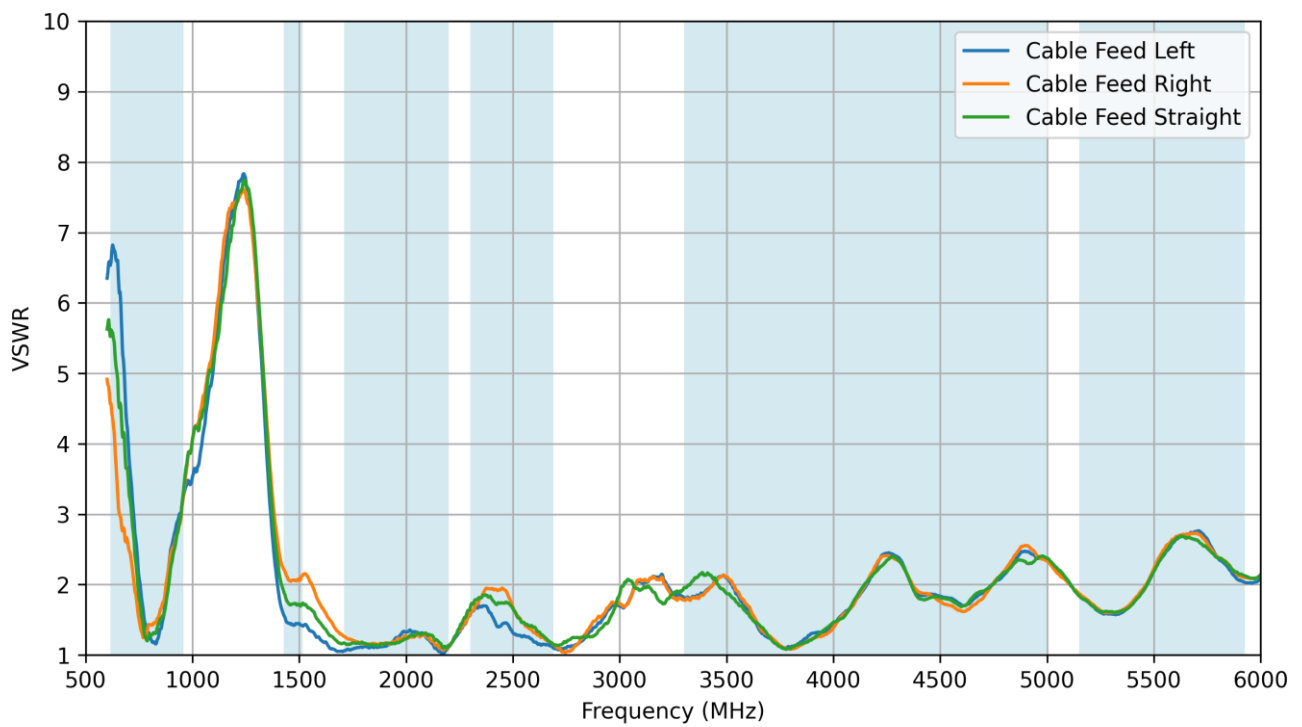

5.4 Efficiency

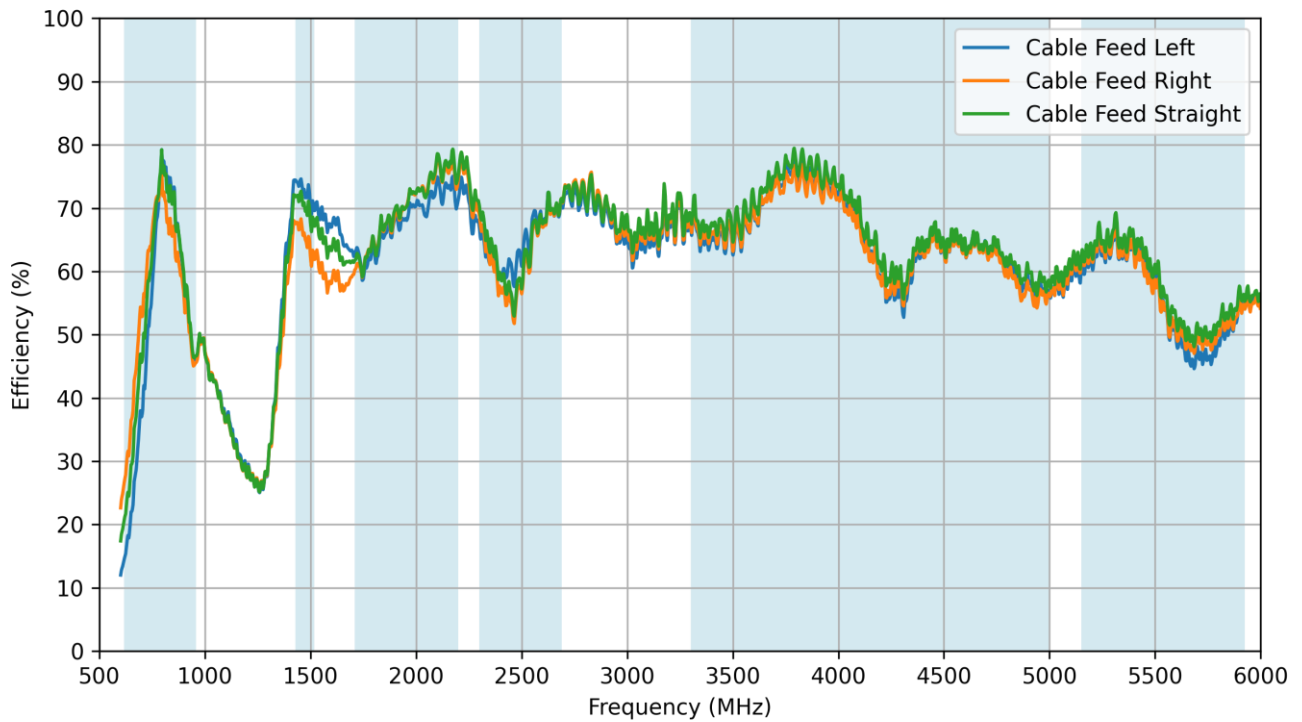

5.5 Average Gain

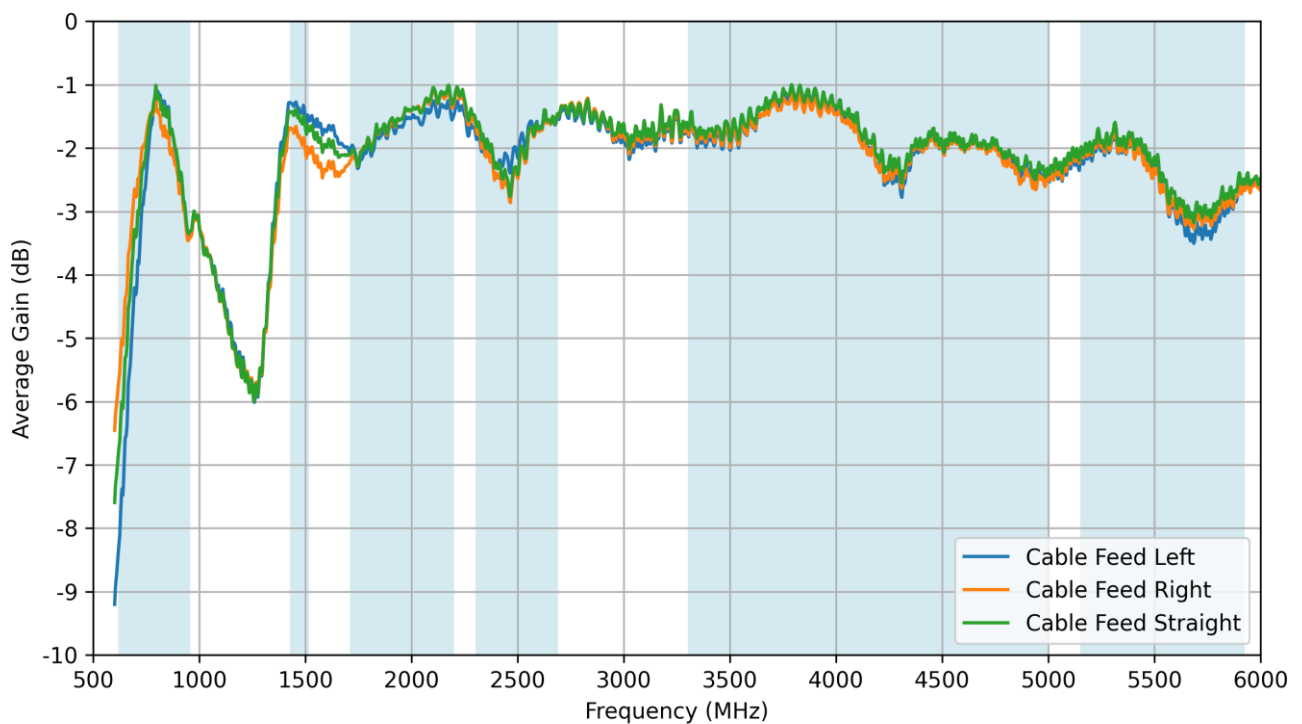

5.6 Peak Gain

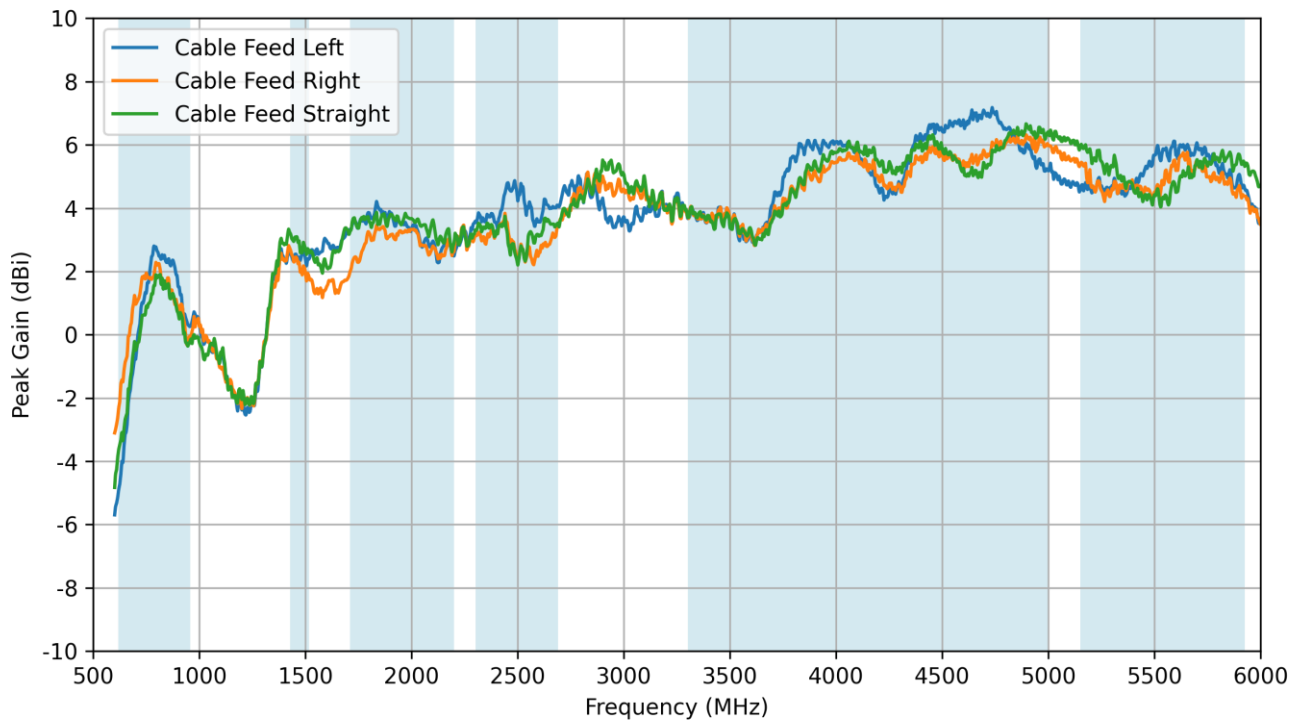

6. Radiation Patterns

6.1 Test Setup

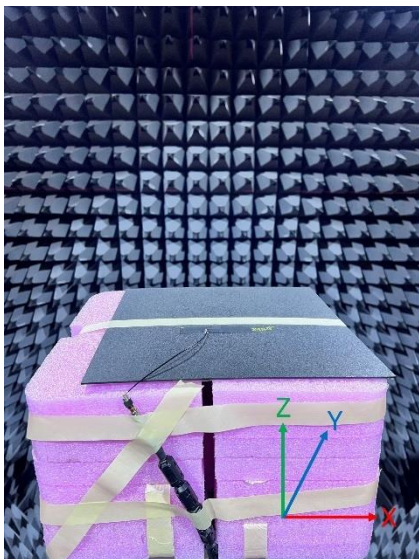
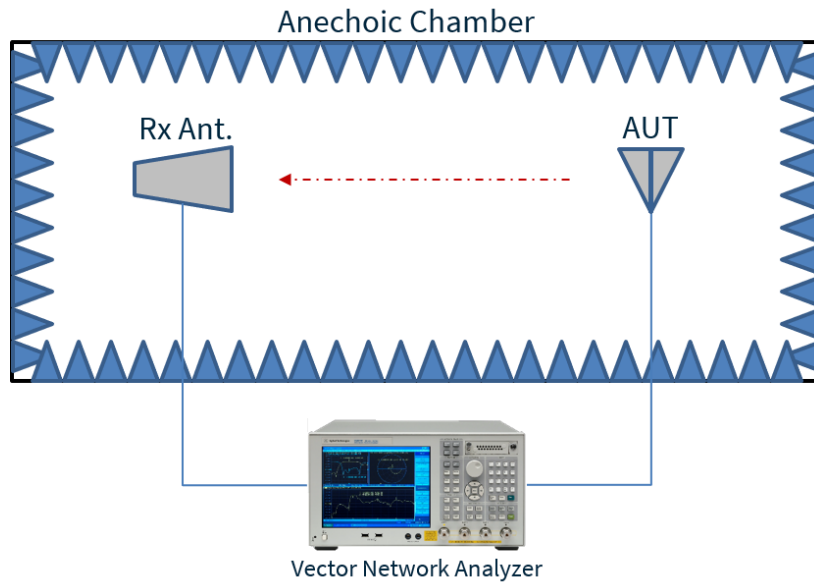

Cable Feed Left

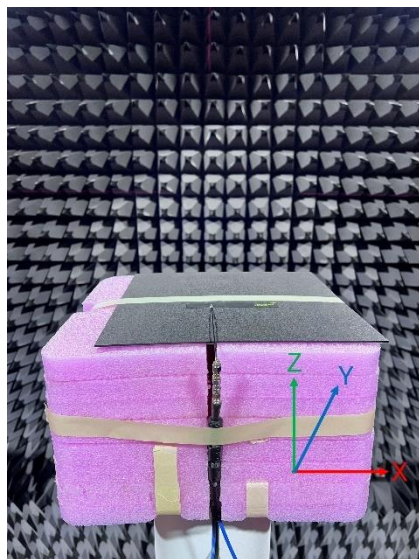

Cable Feed Straight

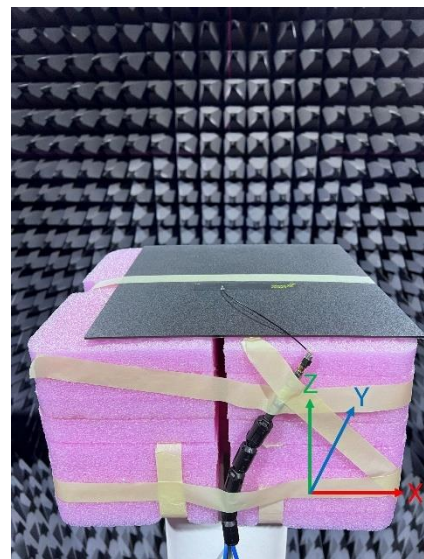

Cable Feed Right

6.2 Cable Feed Left Patterns at 650 MHz

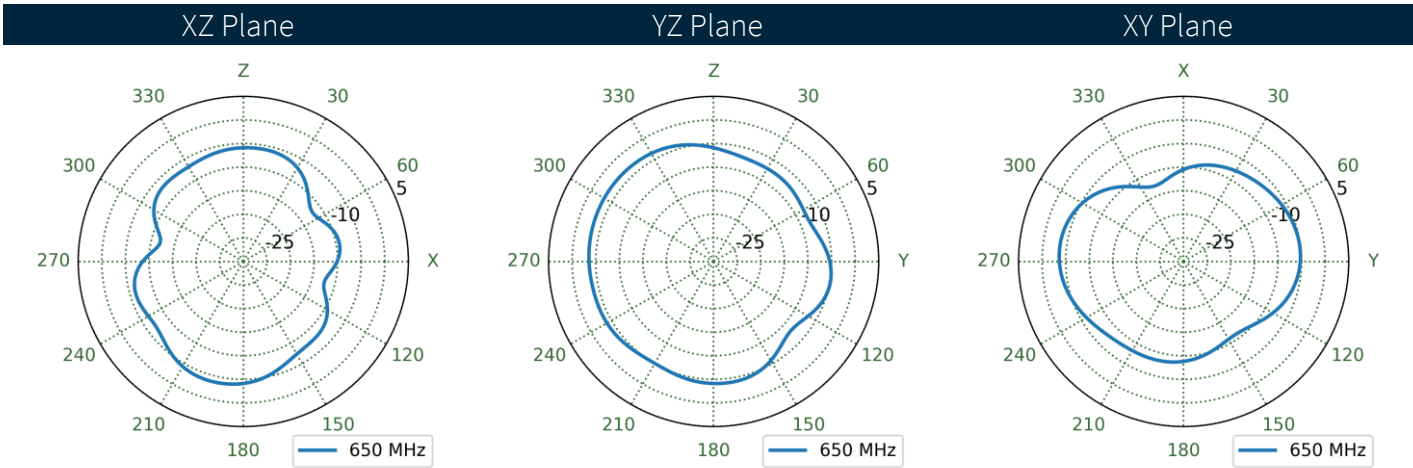
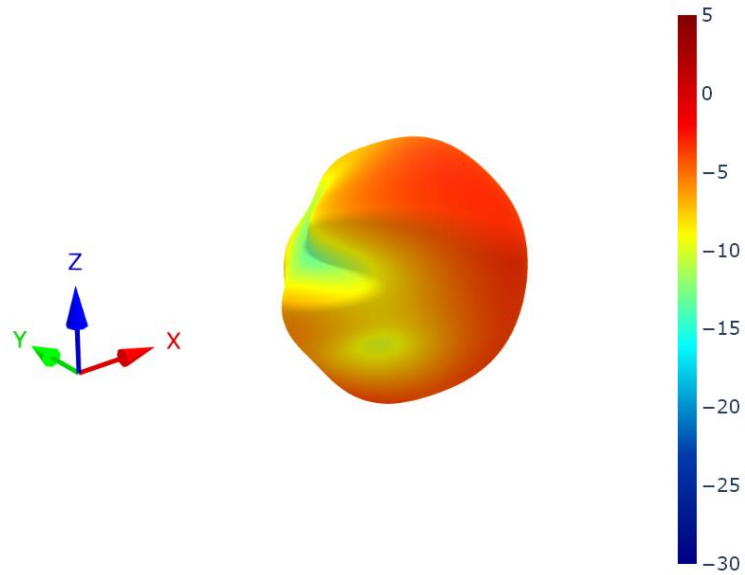

6.3 Cable Feed Right Patterns at 650 MHz

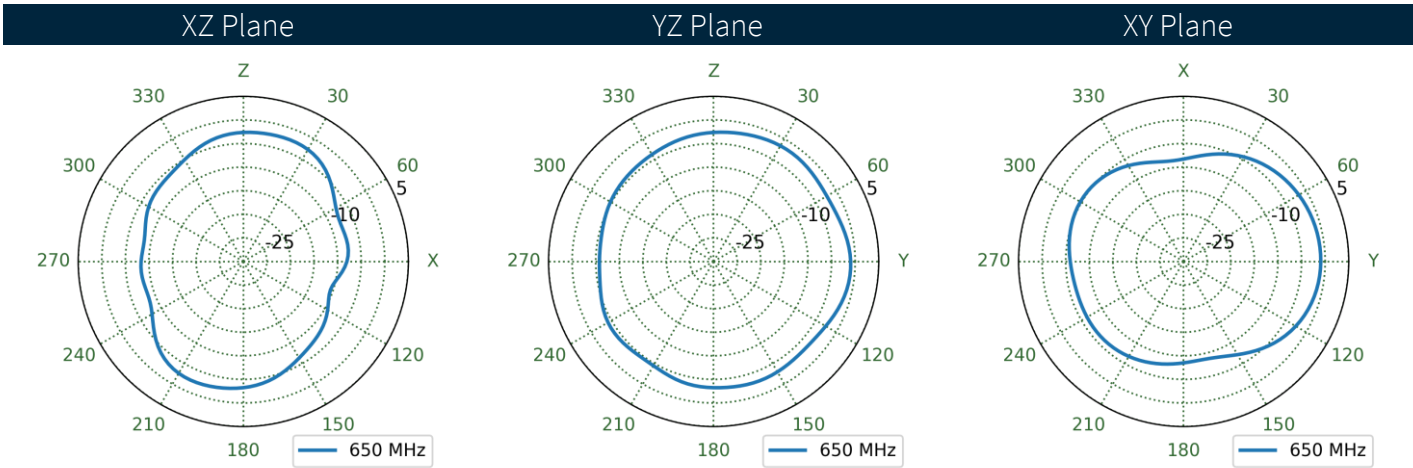
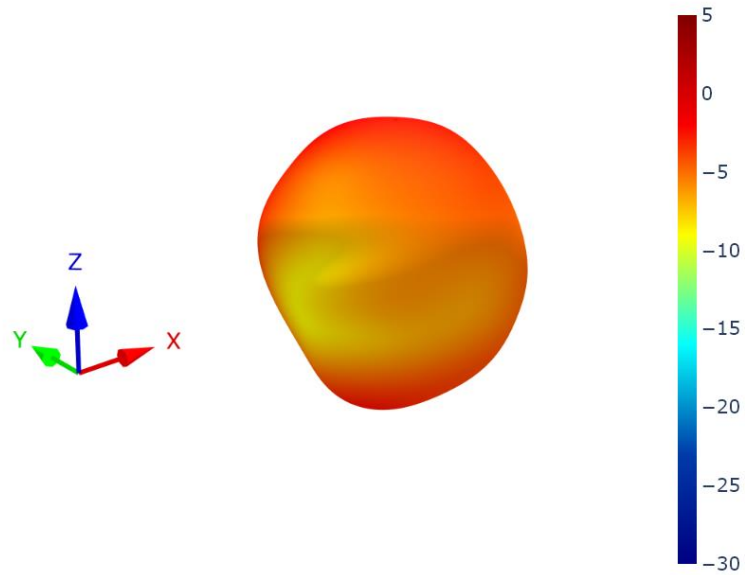

6.4 Cable Feed Straight Patterns at 650 MHz

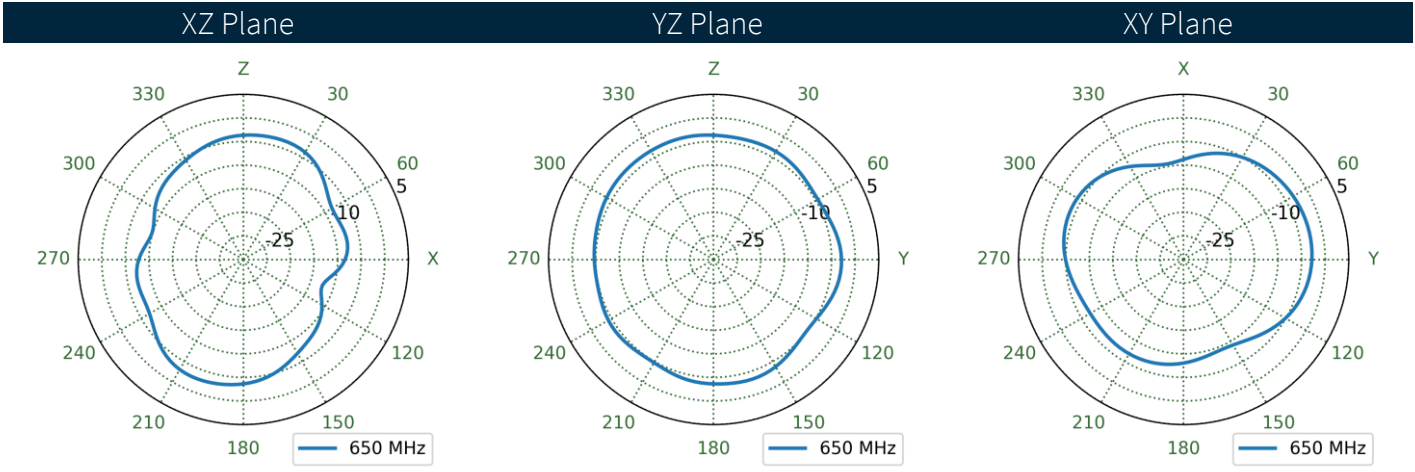
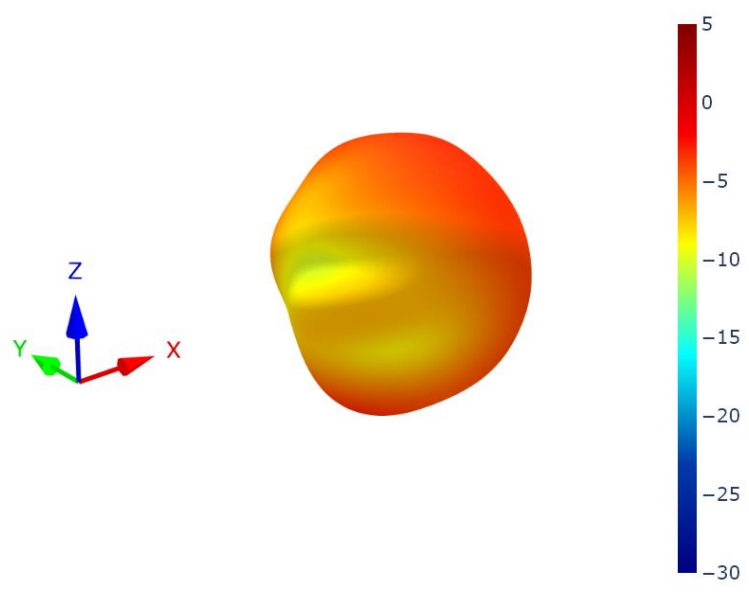

6.5 Cable Feed Left Patterns at 750 MHz

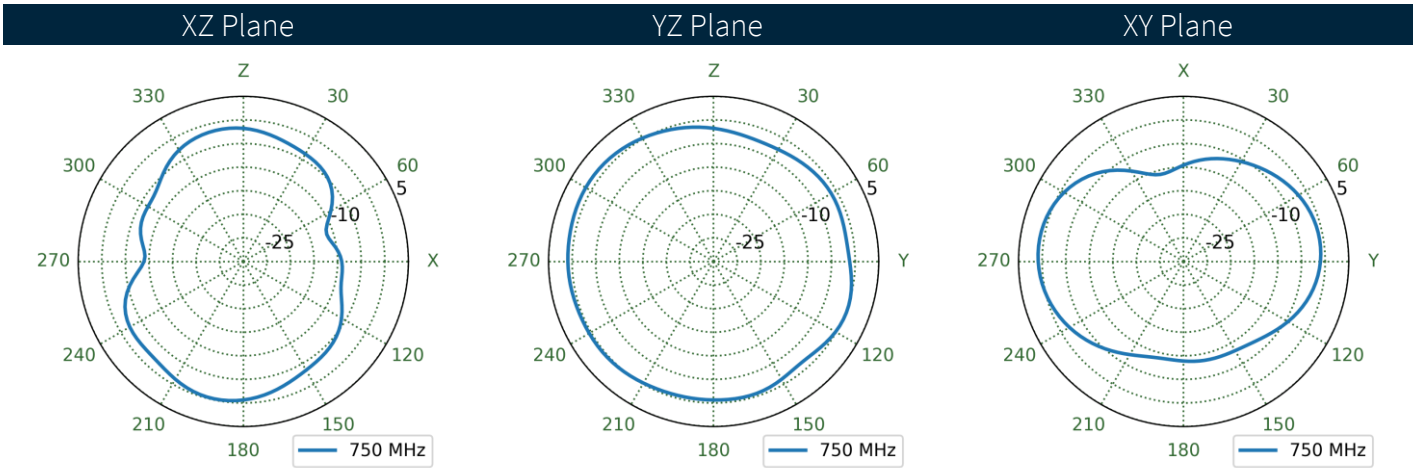
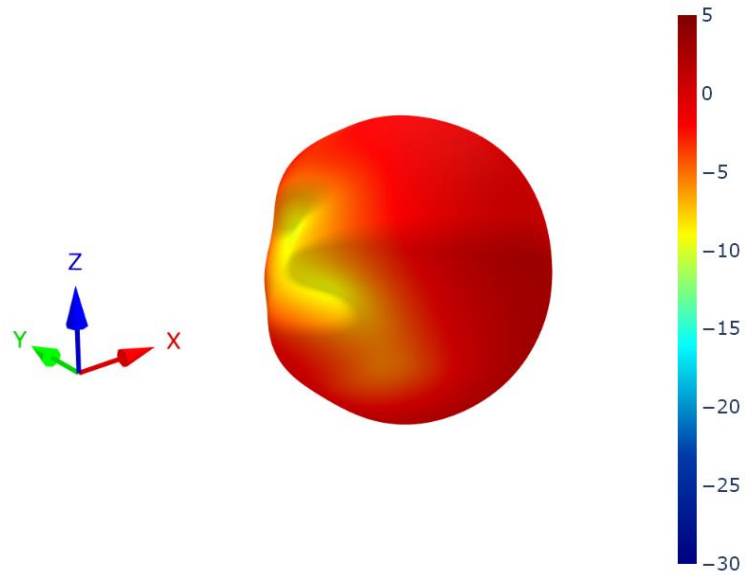

6.6 Cable Feed Right Patterns at 750 MHz

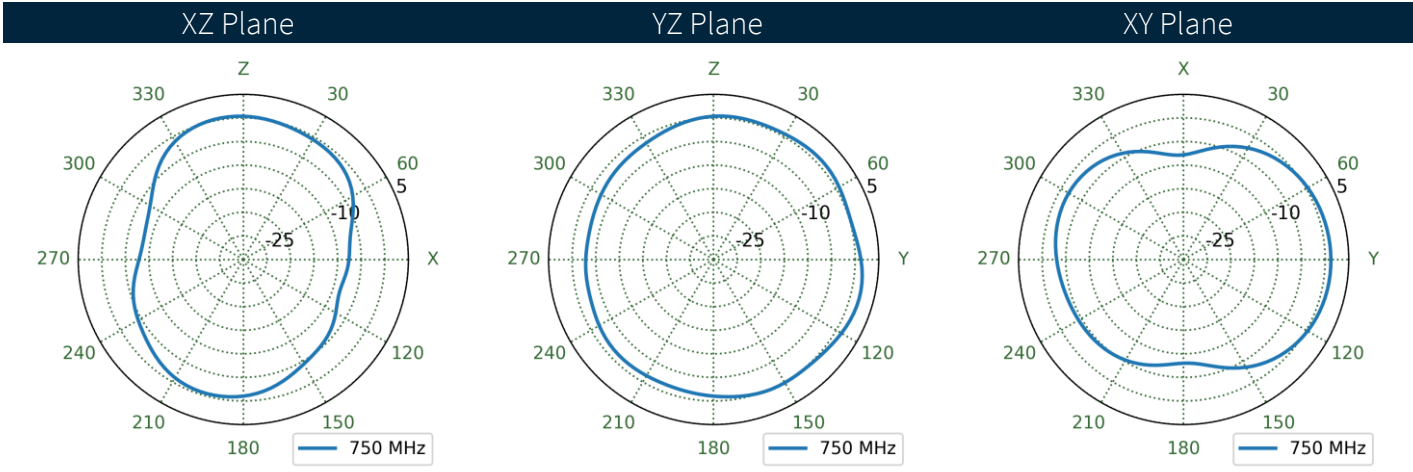
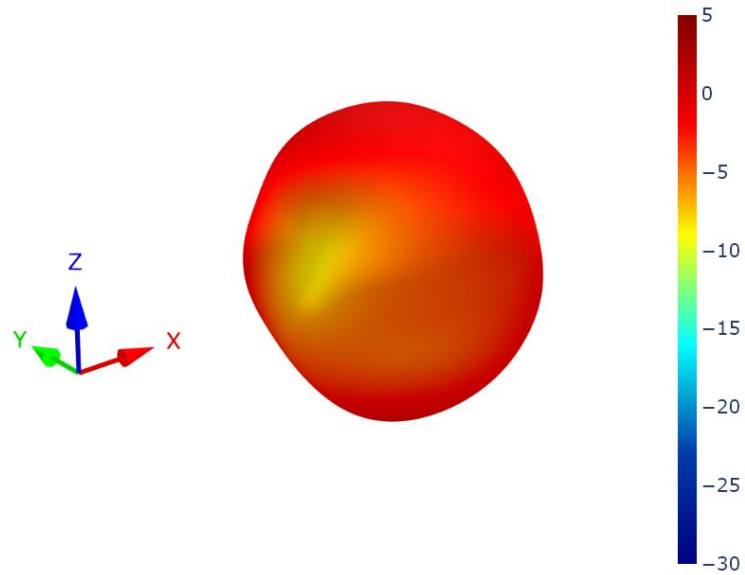

6.7 Cable Feed Straight Patterns at 750 MHz

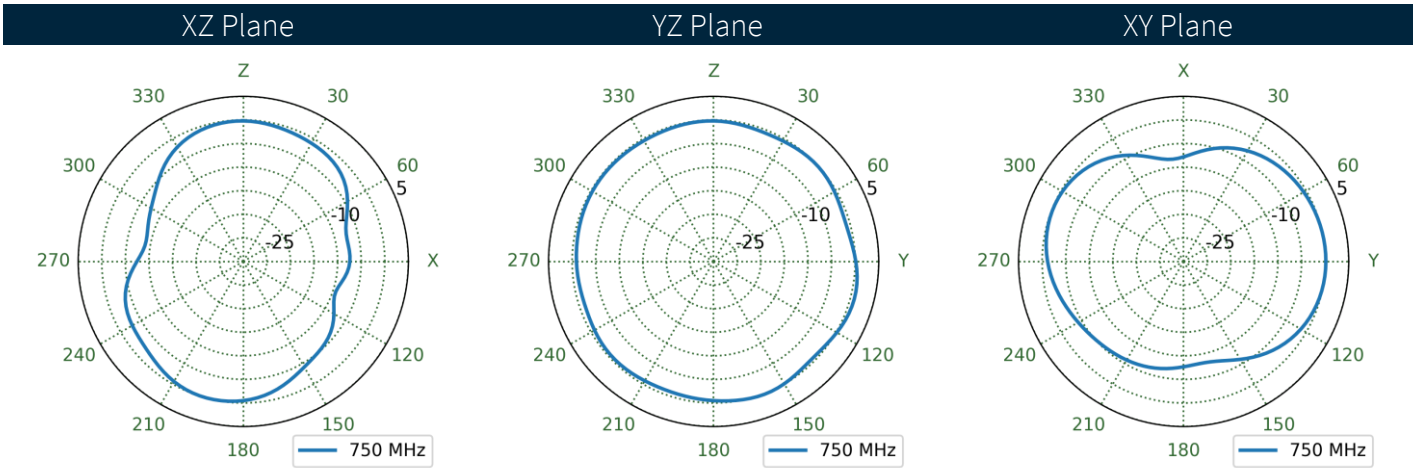
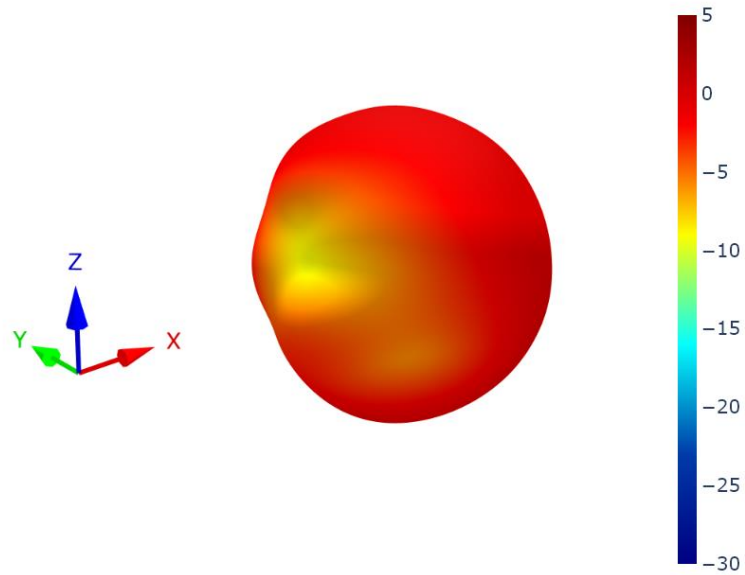

6.8 Cable Feed Left Patterns at 890 MHz

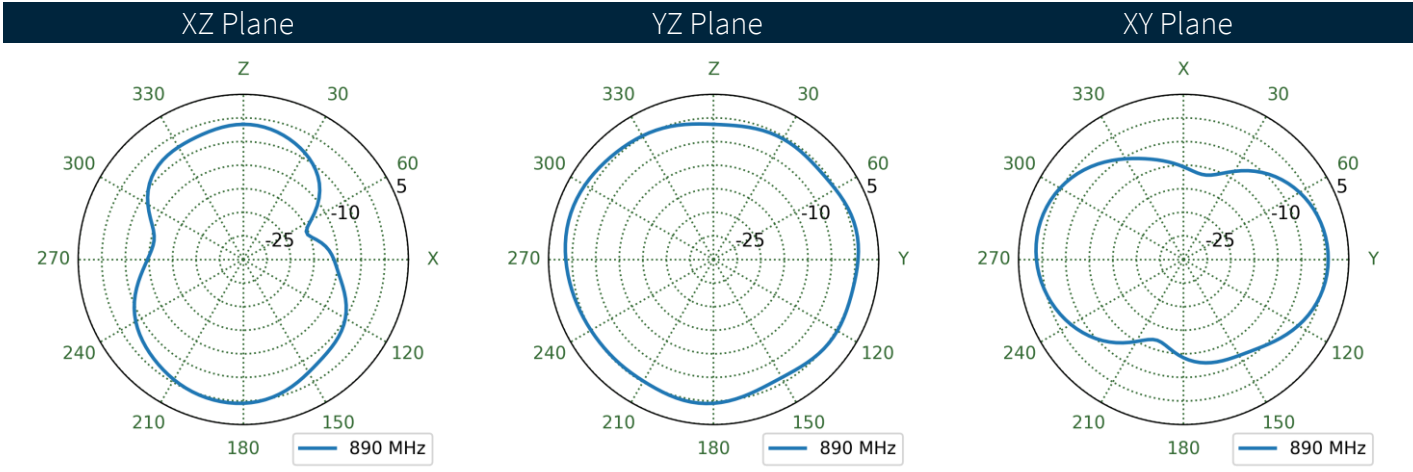
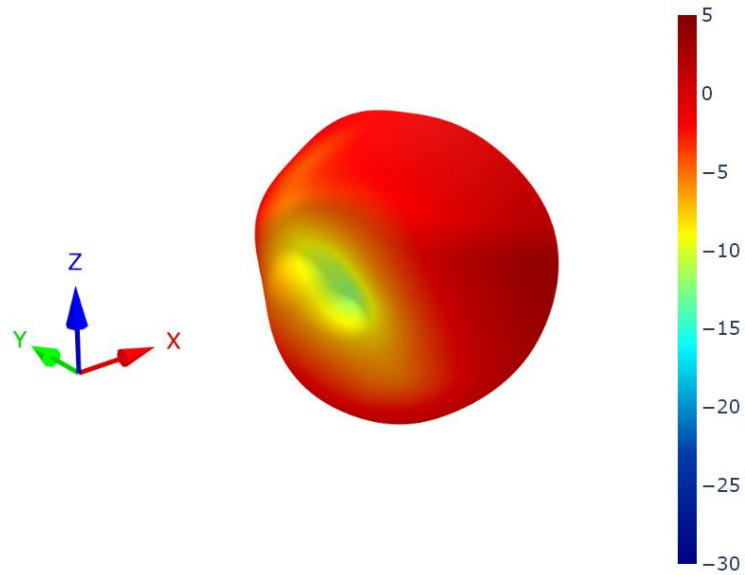

6.9 Cable Feed Right Patterns at 890 MHz

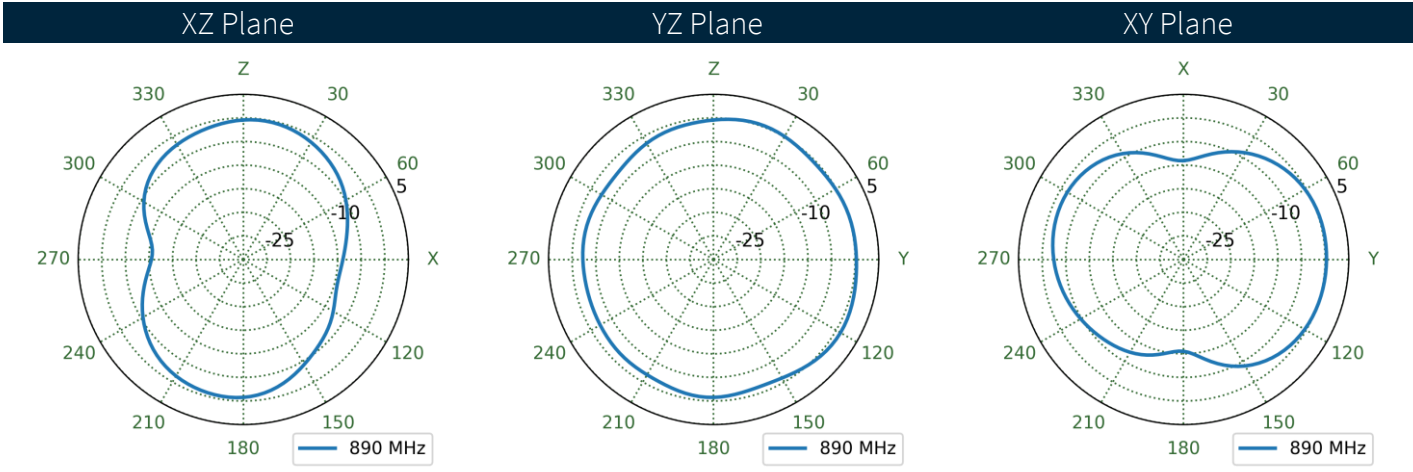
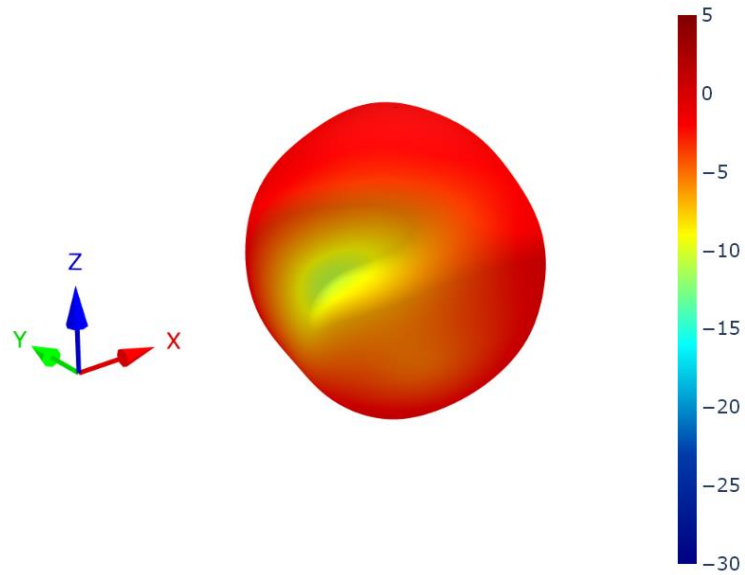

6.10 Cable Feed Straight Patterns at 890 MHz

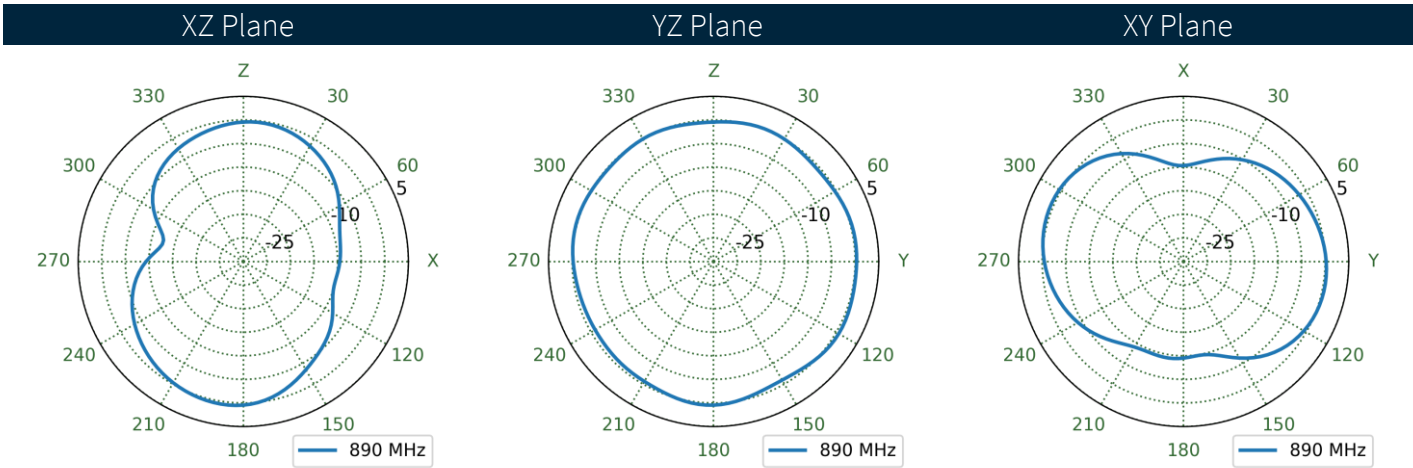
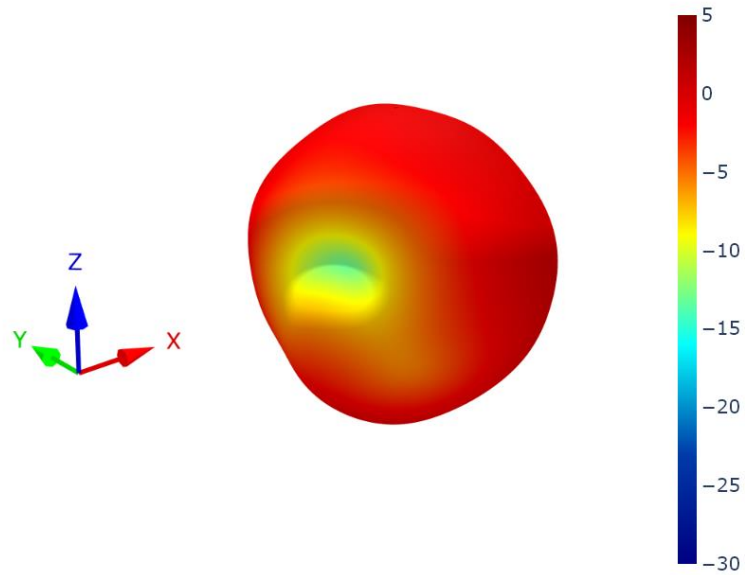

6.11 Cable Feed Left Patterns at 1470 MHz

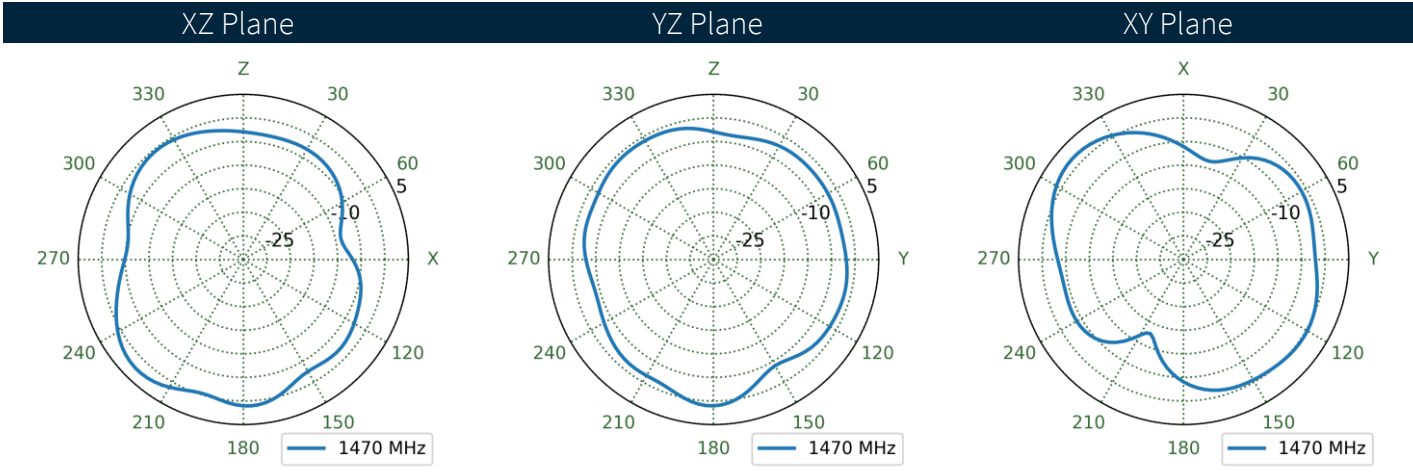
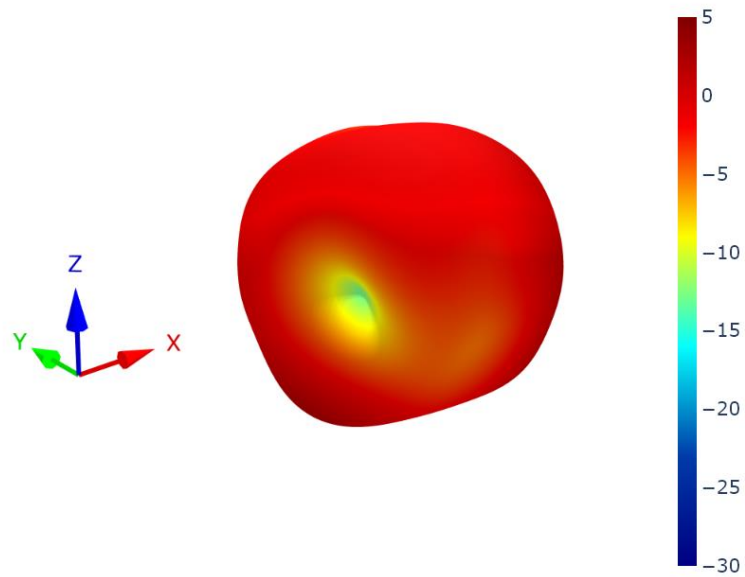

6.12 Cable Feed Right Patterns at 1470 MHz

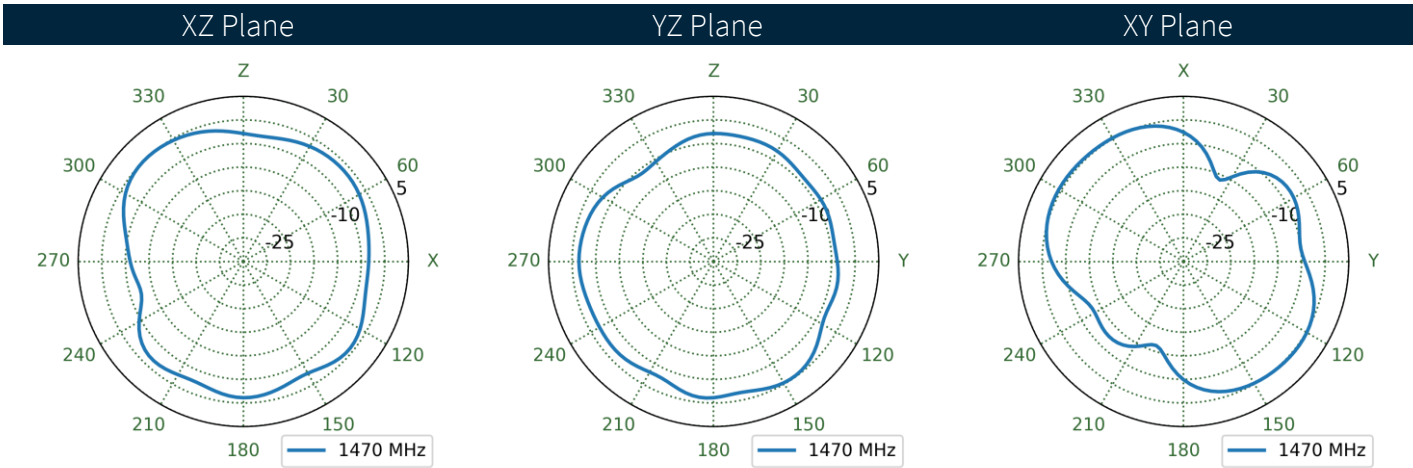
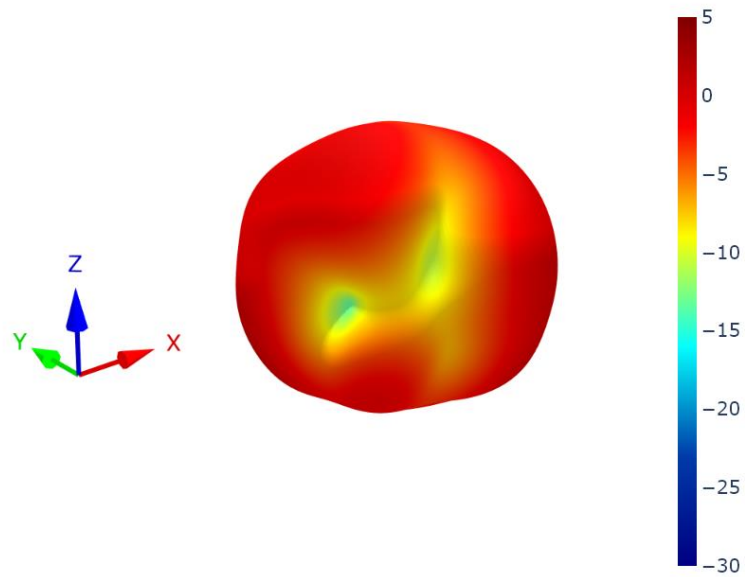

6.13 Cable Feed Straight Patterns at 1470 MHz

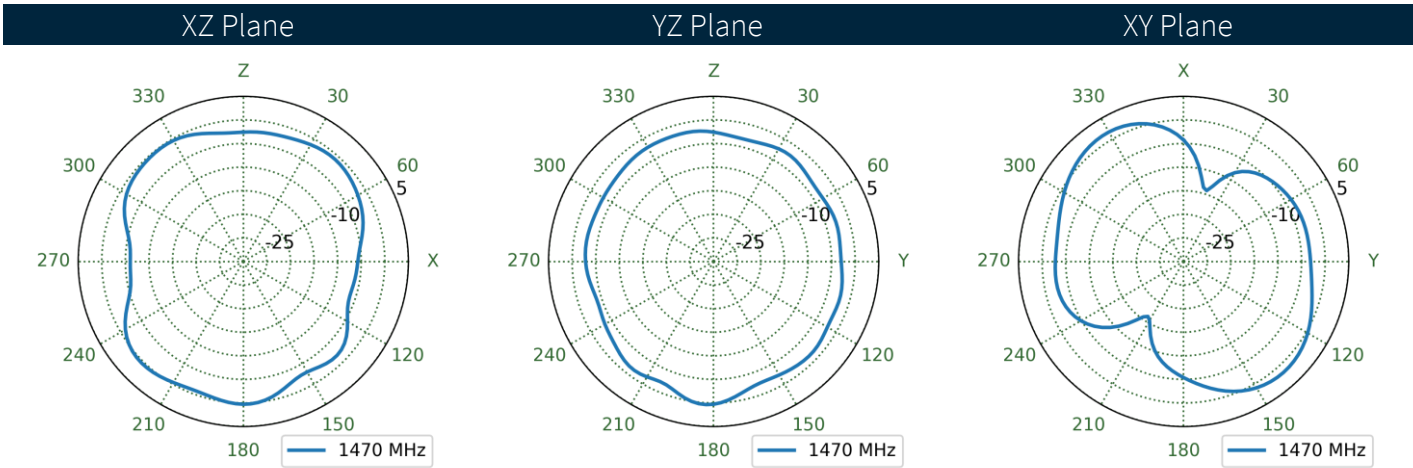
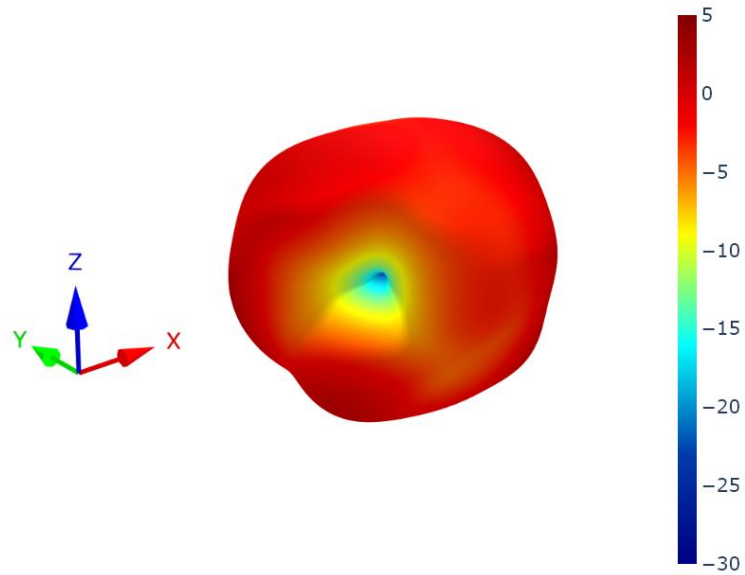

6.14 Cable Feed Left Patterns at 1805 MHz

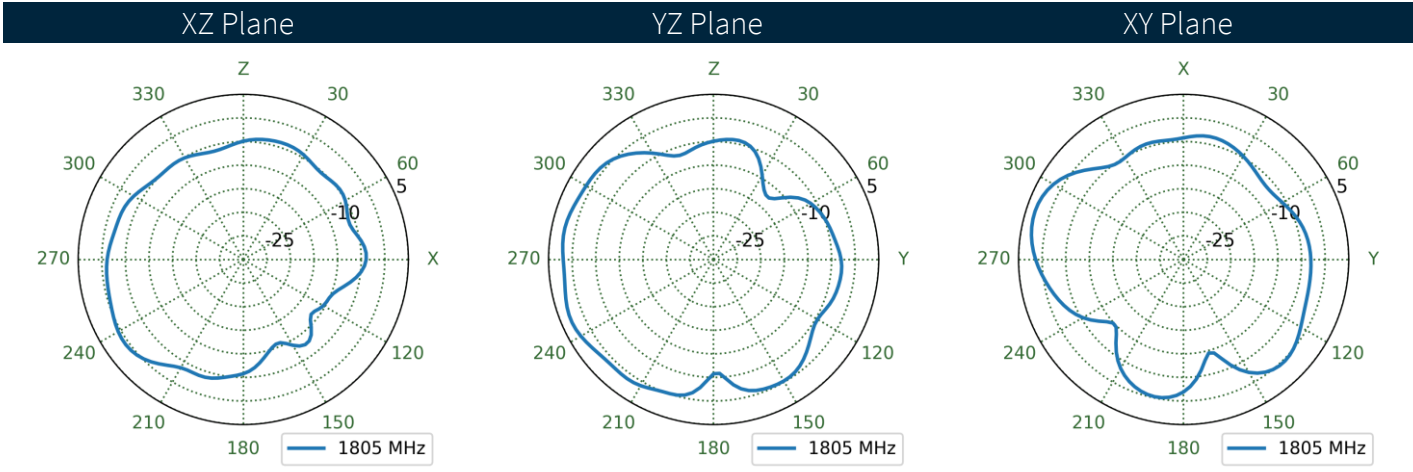
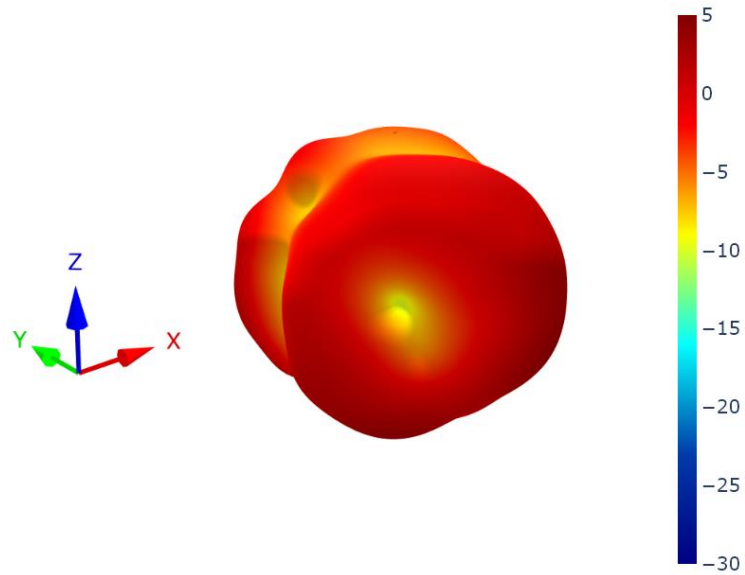

6.15 Cable Feed Right Patterns at 1805 MHz

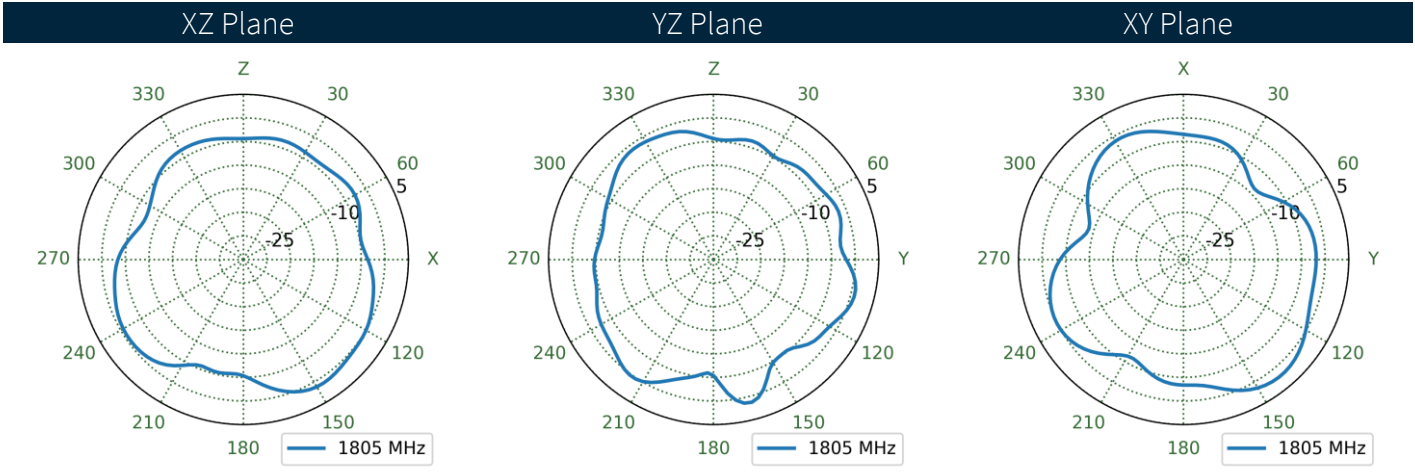
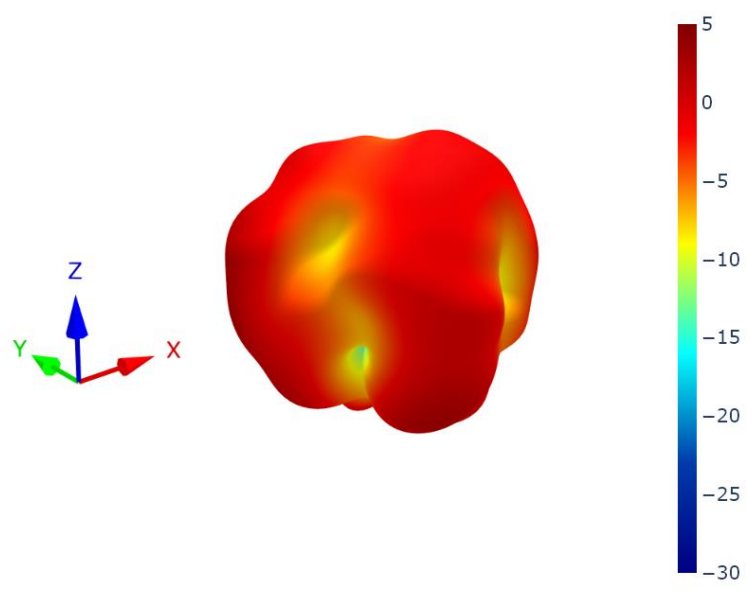

6.16 Cable Feed Straight Patterns at 1805 MHz

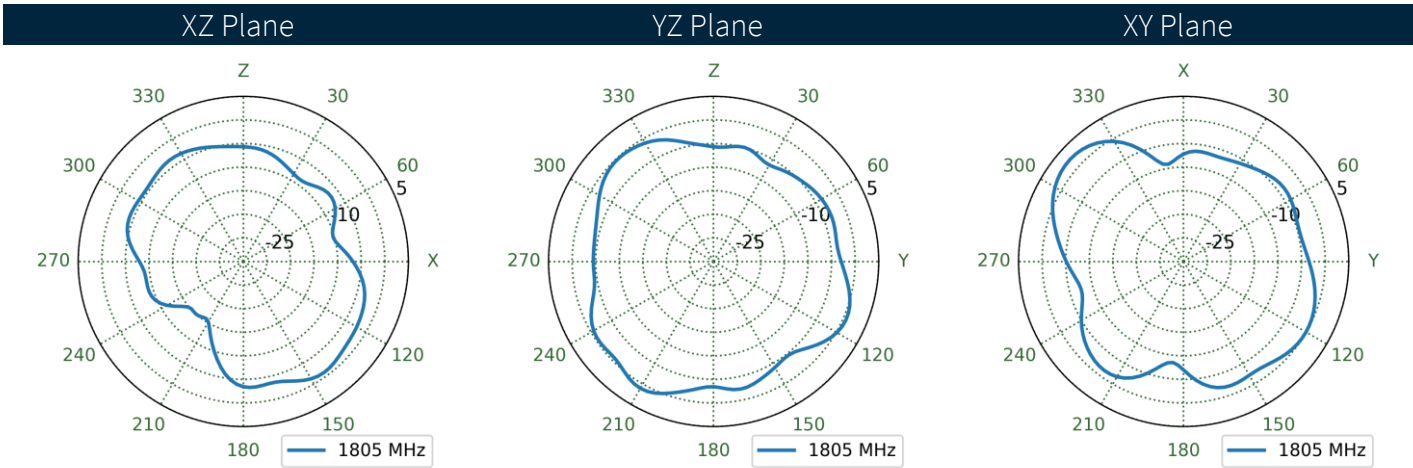
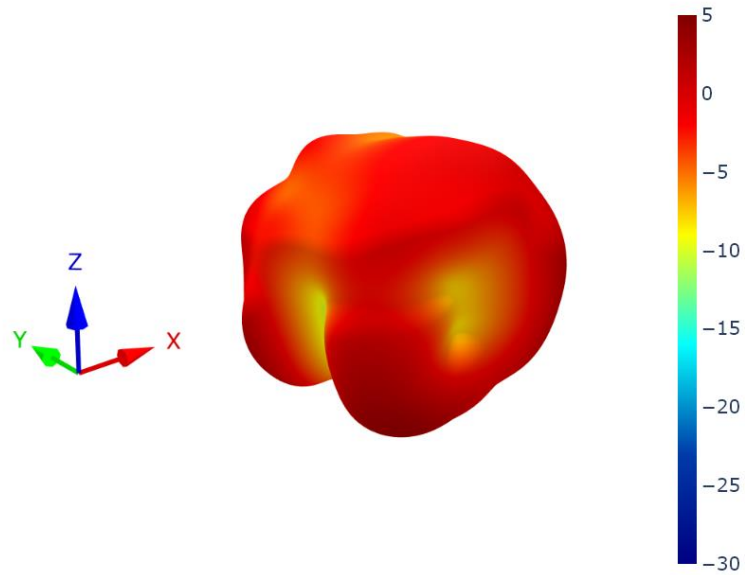

6.17 Cable Feed Left Patterns at 1920 MHz

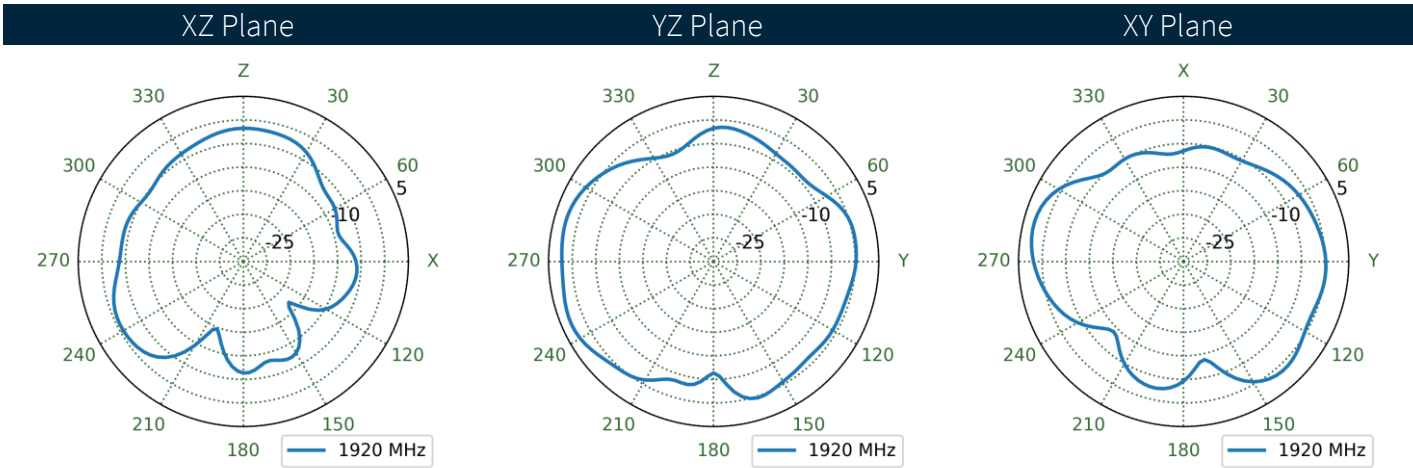
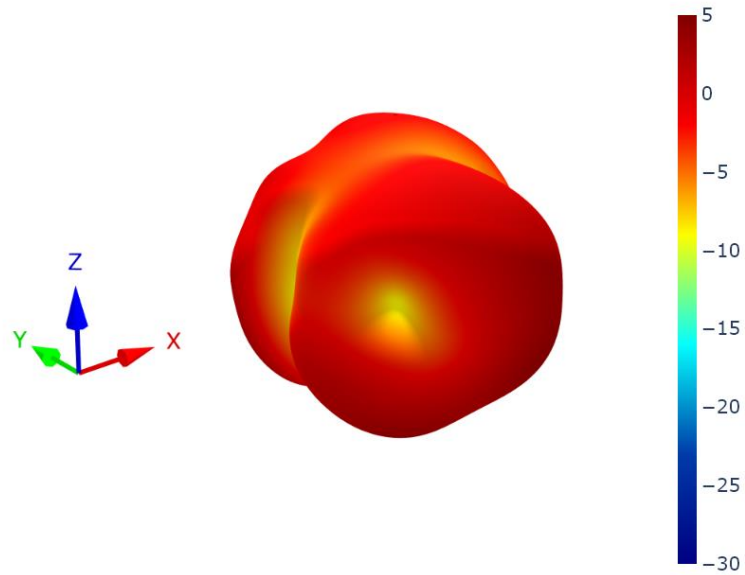

6.18 Cable Feed Right Patterns at 1920 MHz

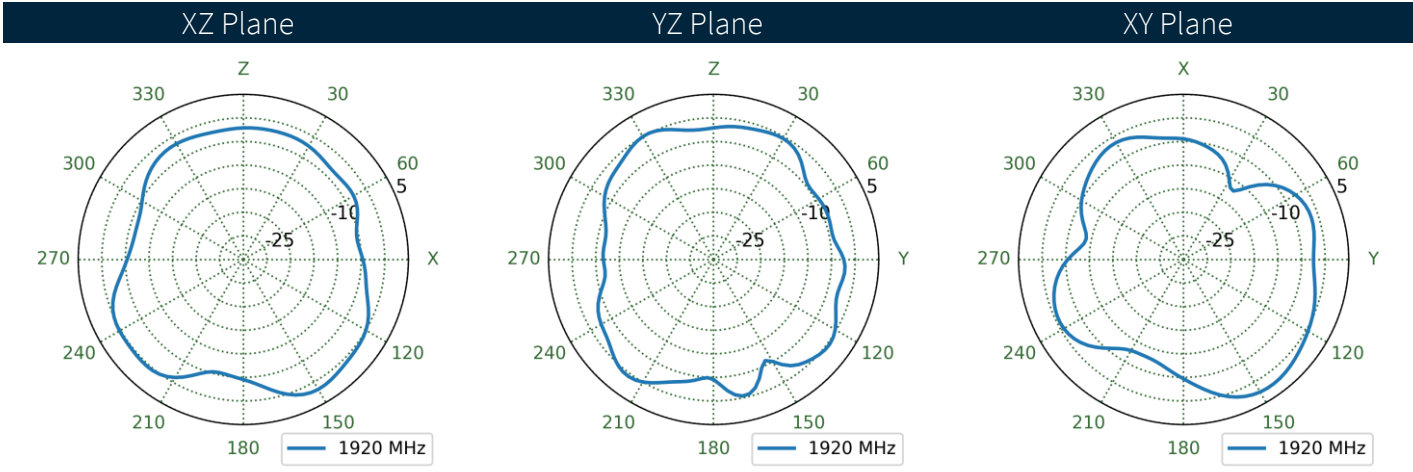
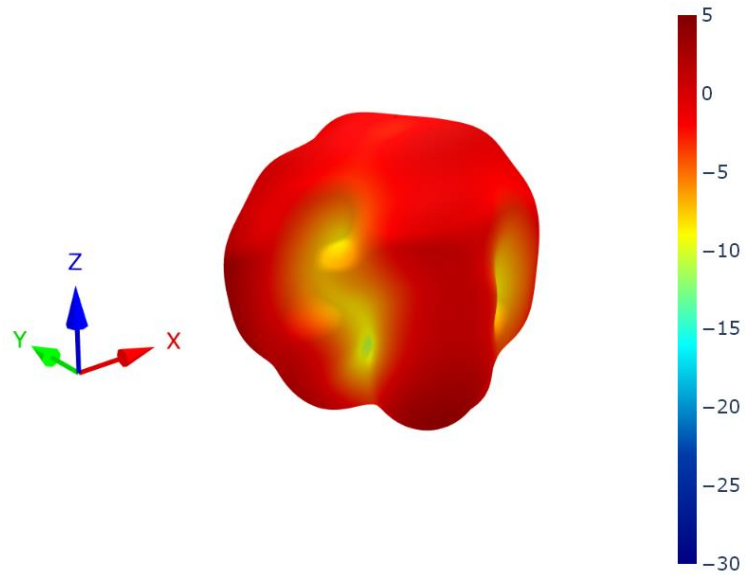

6.19 Cable Feed Straight Patterns at 1920 MHz

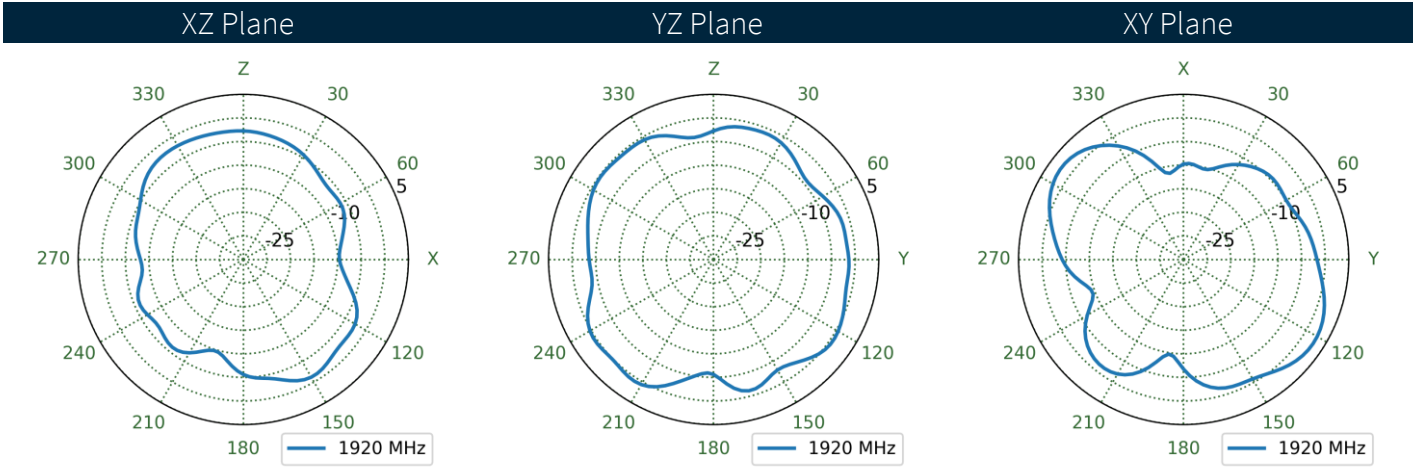
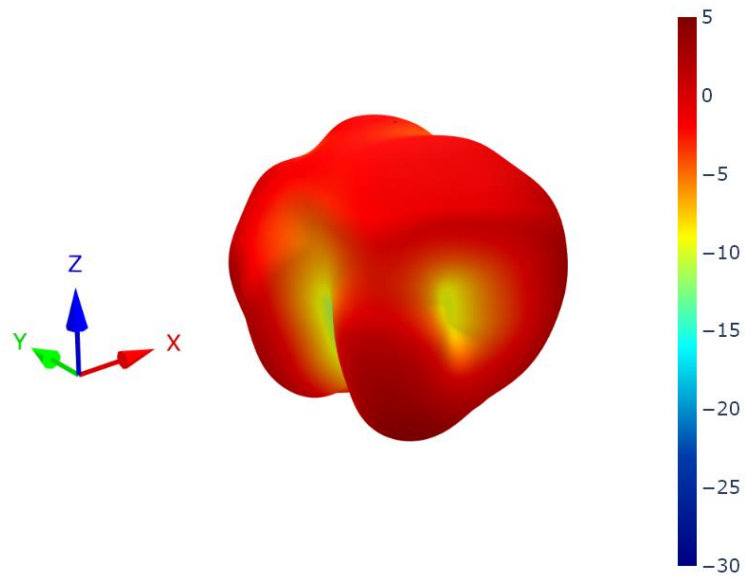

6.20 Cable Feed Left Patterns at 1990 MHz

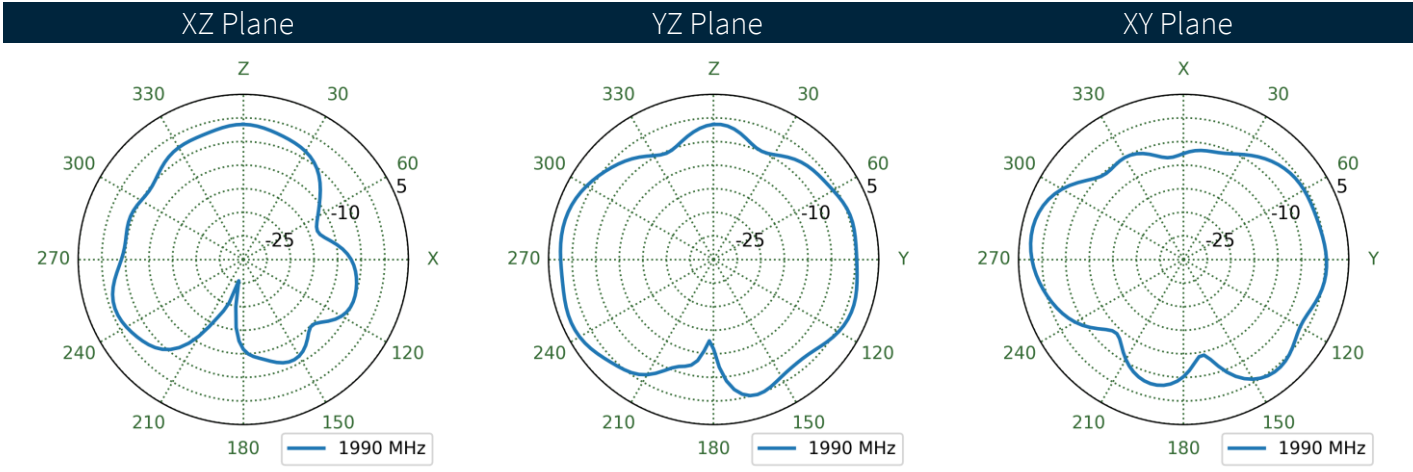
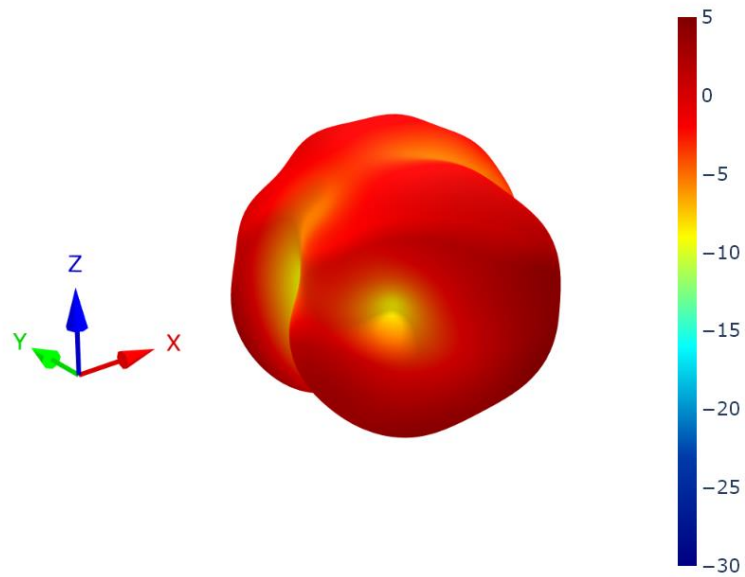

6.21 Cable Feed Right Patterns at 1990 MHz

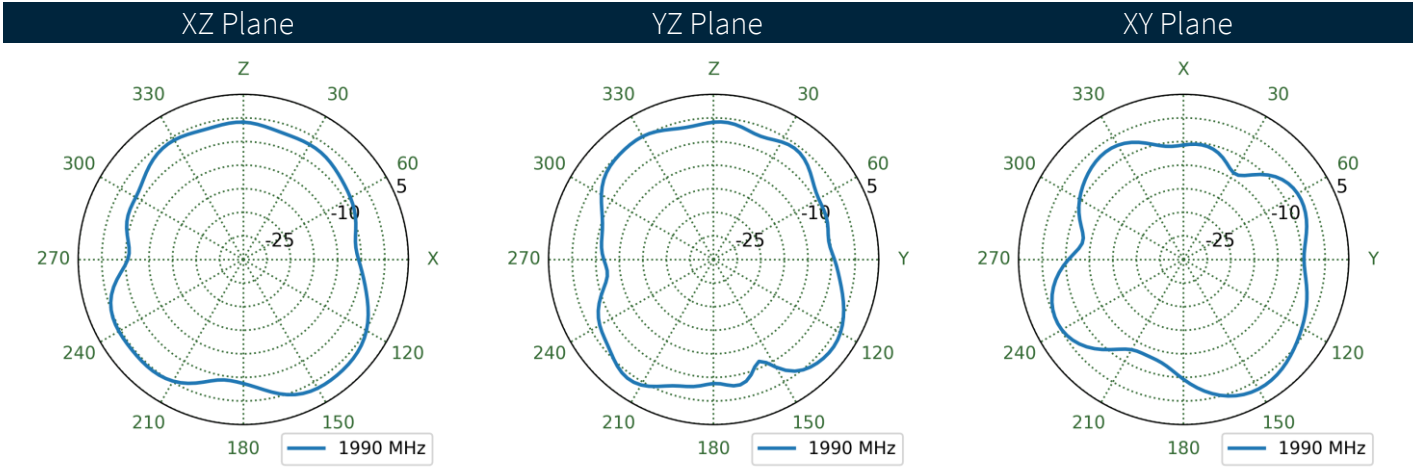
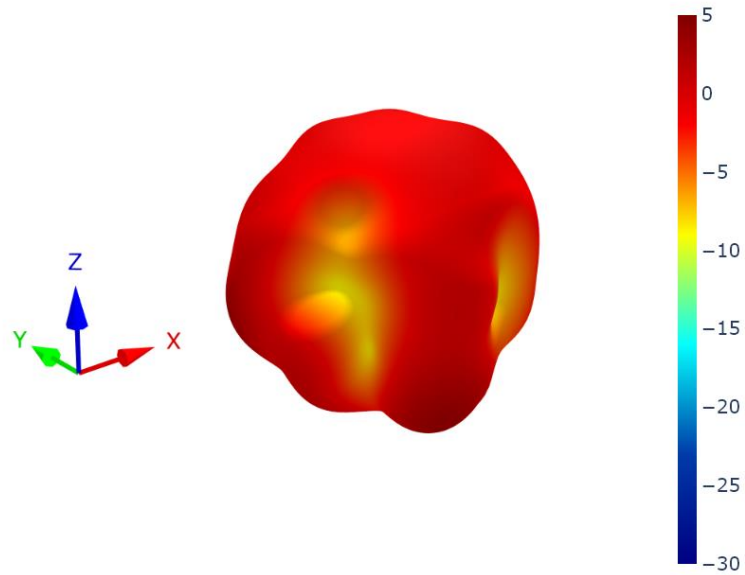

6.22 Cable Feed Straight Patterns at 1990 MHz

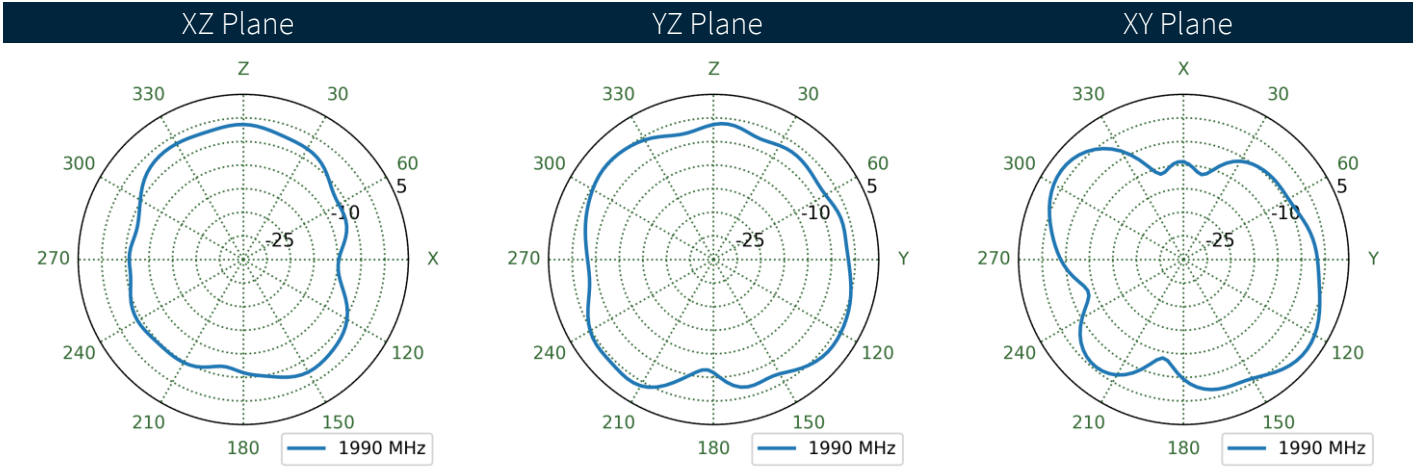
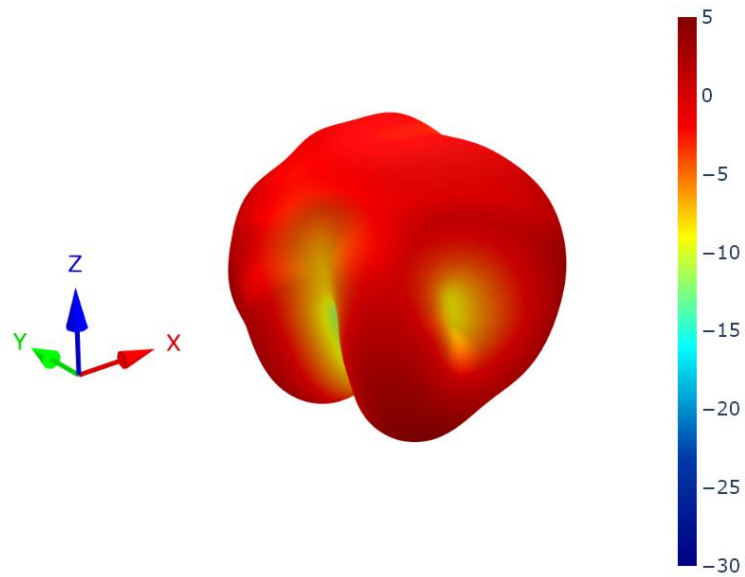

6.23 Cable Feed Left Patterns at 2360 MHz

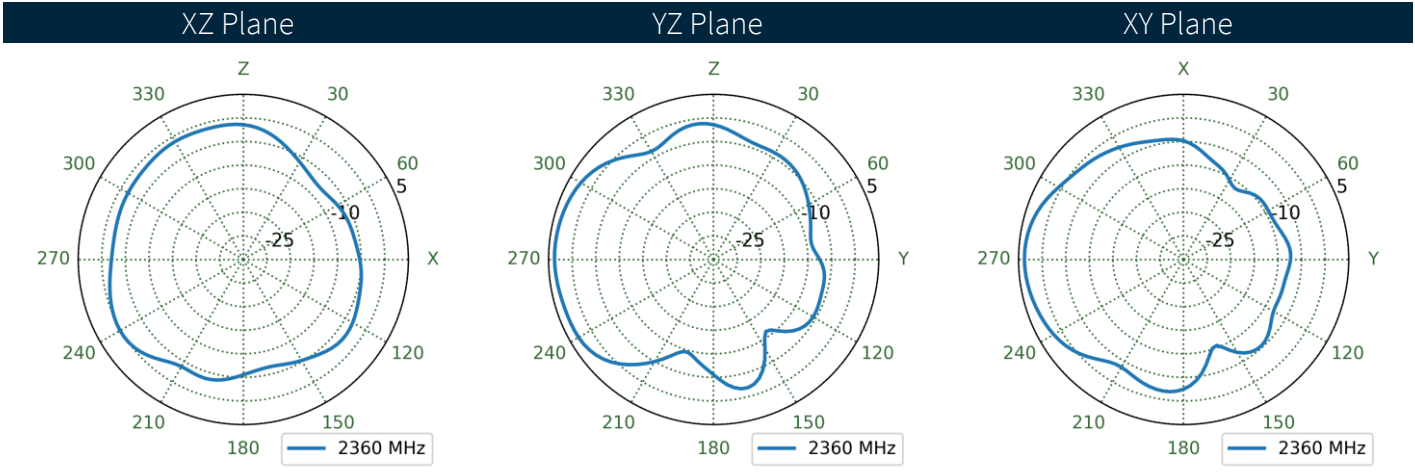
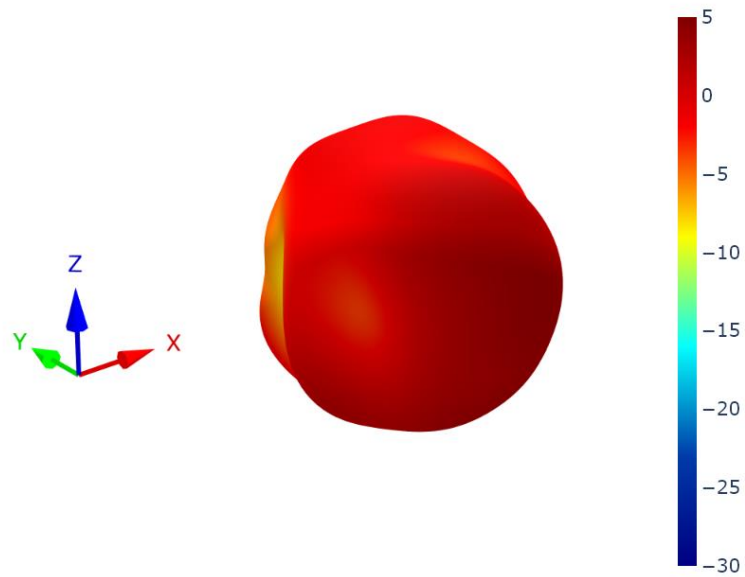

6.24 Cable Feed Right Patterns at 2360 MHz

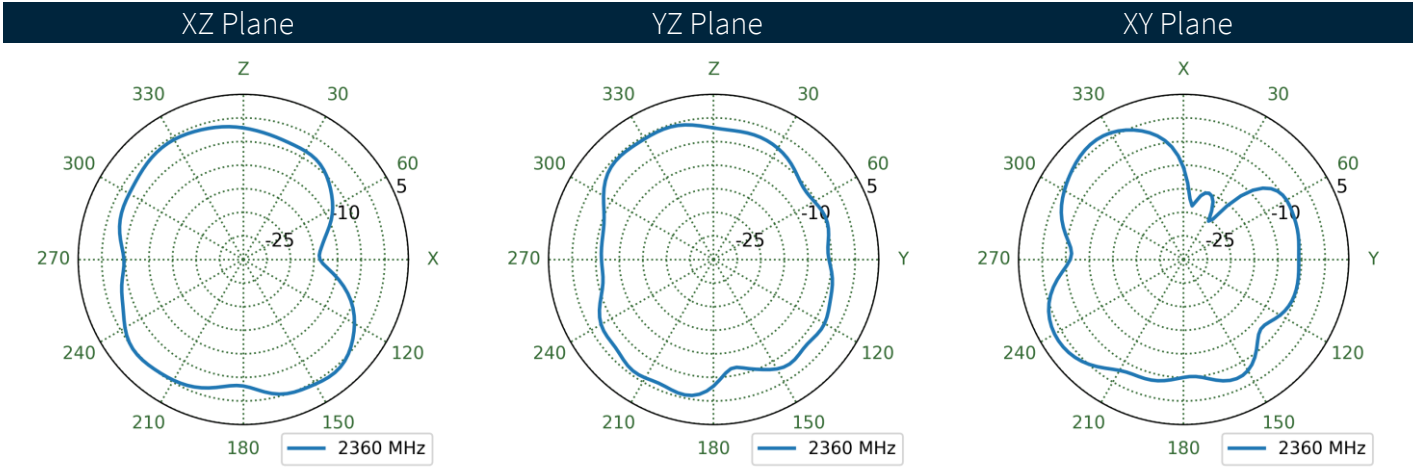
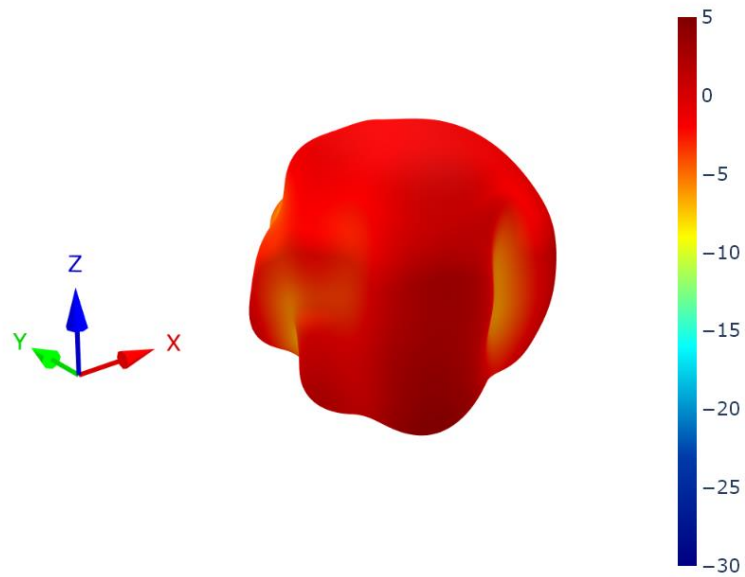

6.25 Cable Feed Straight Patterns at 2360 MHz

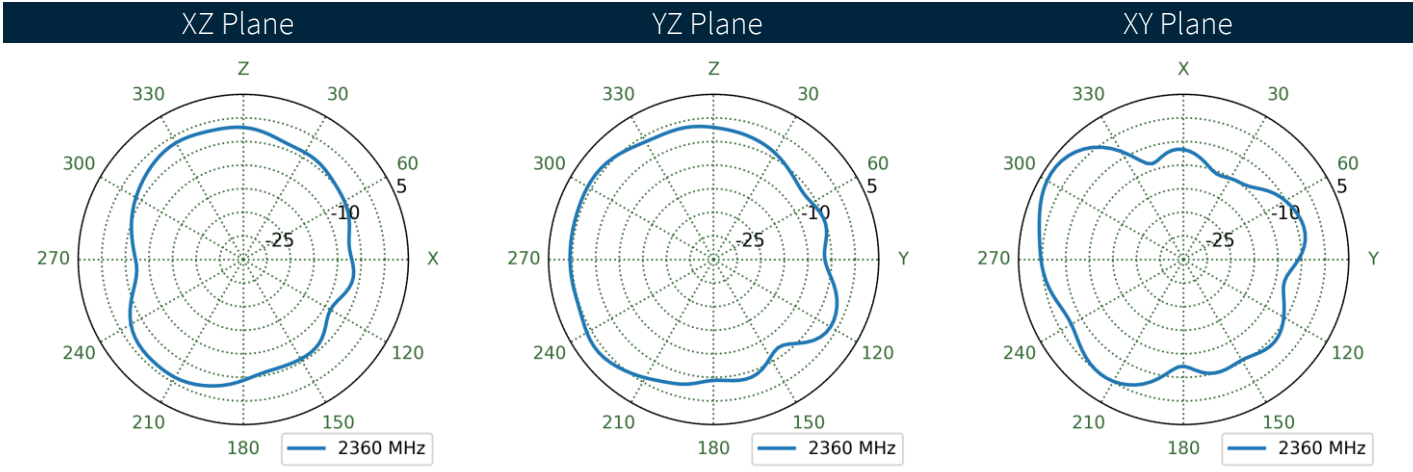
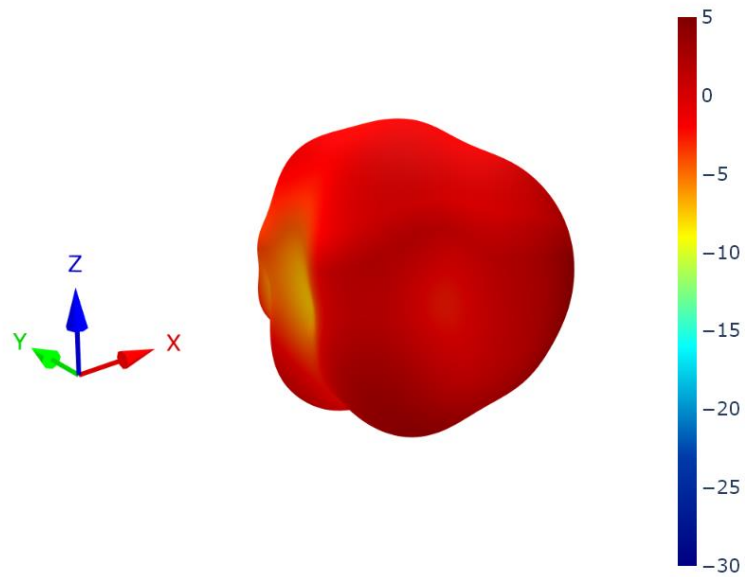

6.26 Cable Feed Left Patterns at 2595 MHz

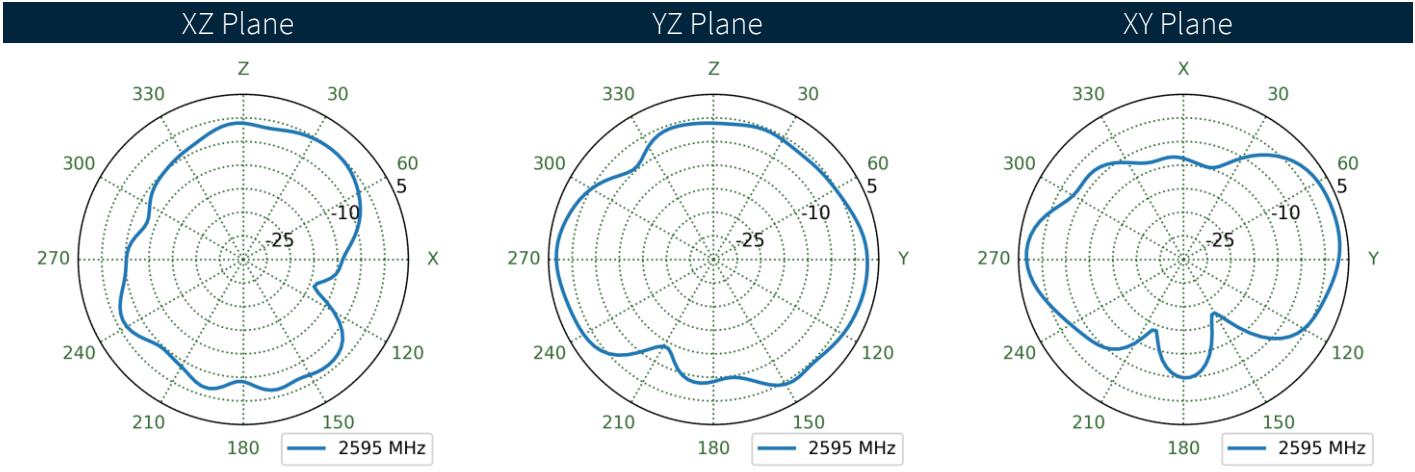
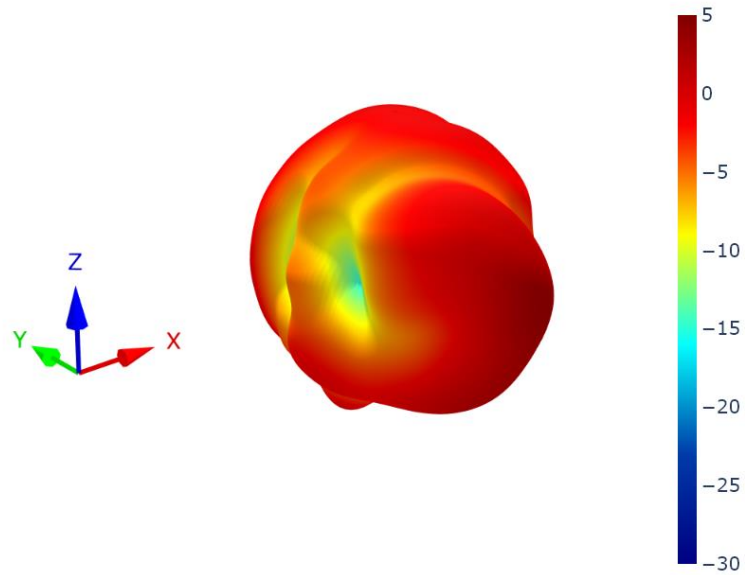

6.27 Cable Feed Right Patterns at 2595 MHz

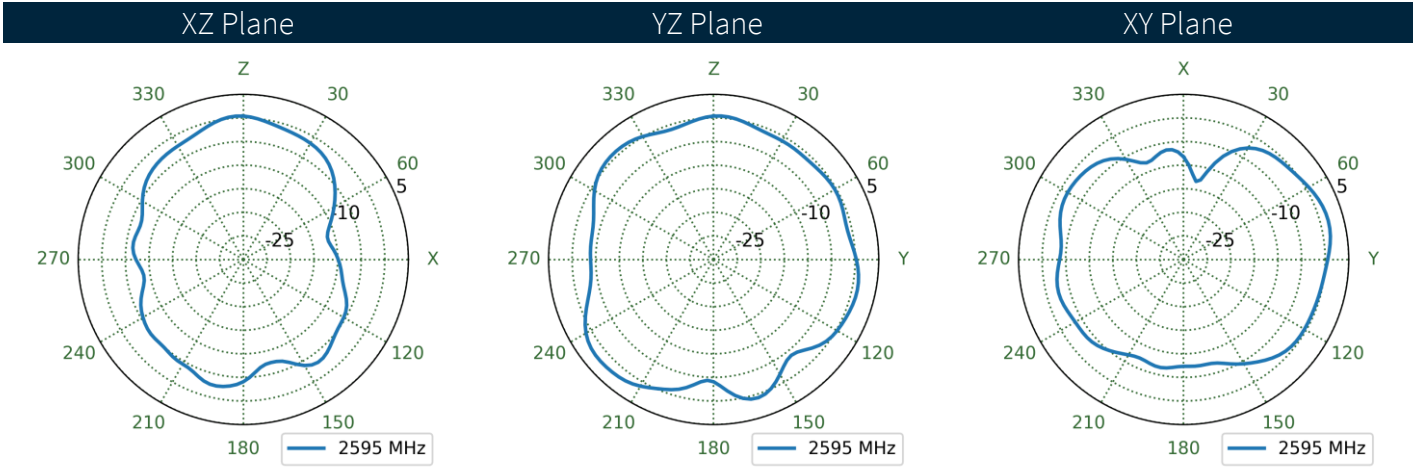
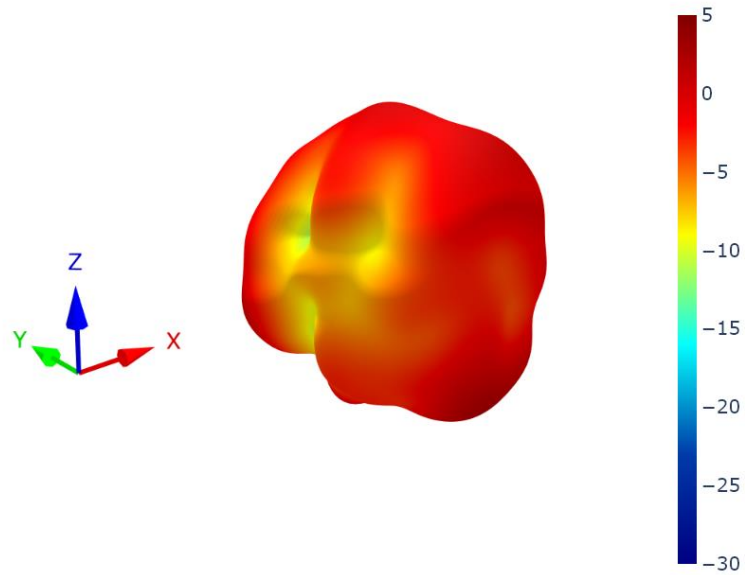

6.28 Cable Feed Straight Patterns at 2595 MHz

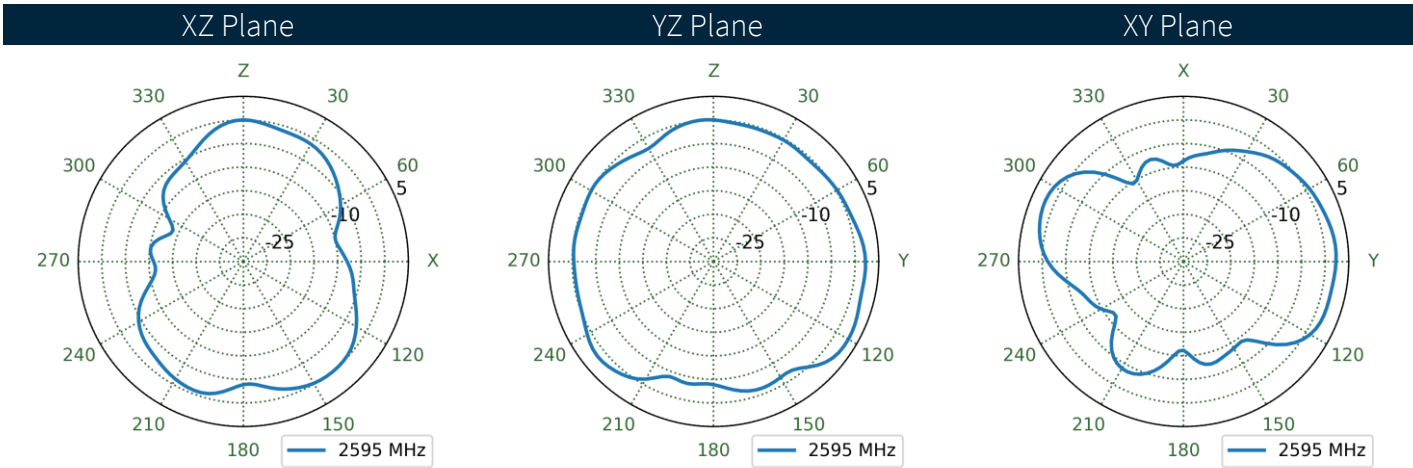
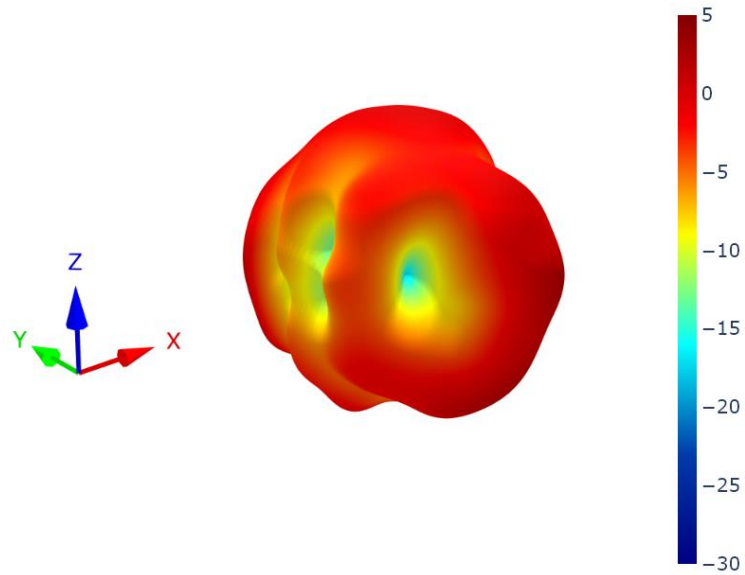

6.29 Cable Feed Left Patterns at 3550 MHz

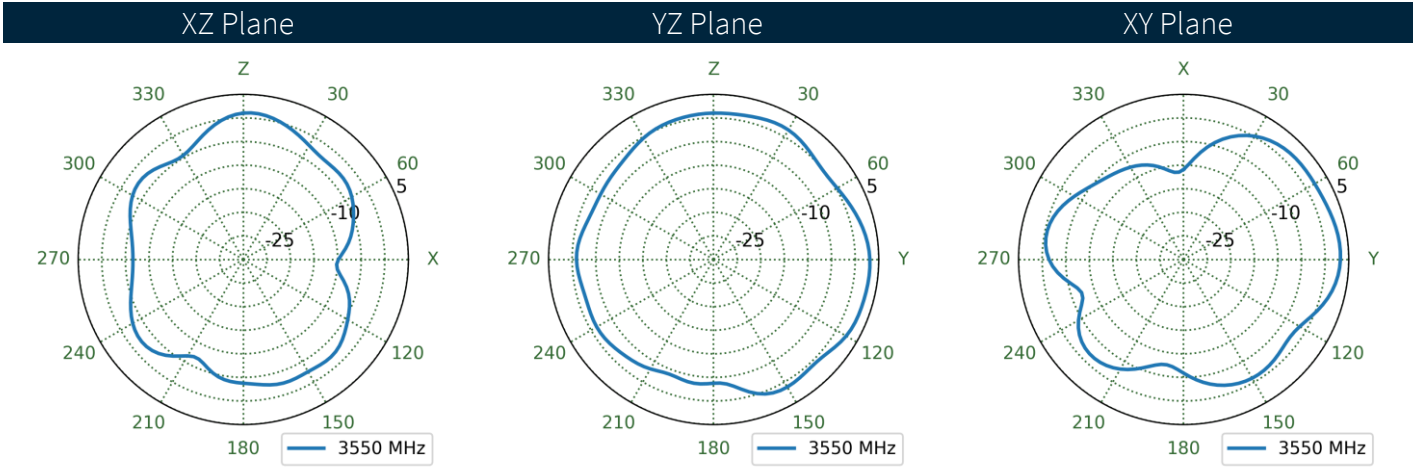
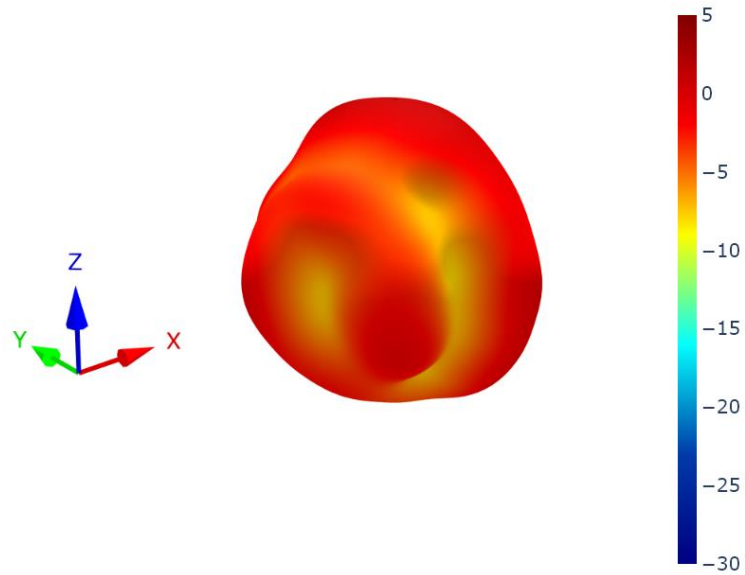

6.30 Cable Feed Right Patterns at 3550 MHz

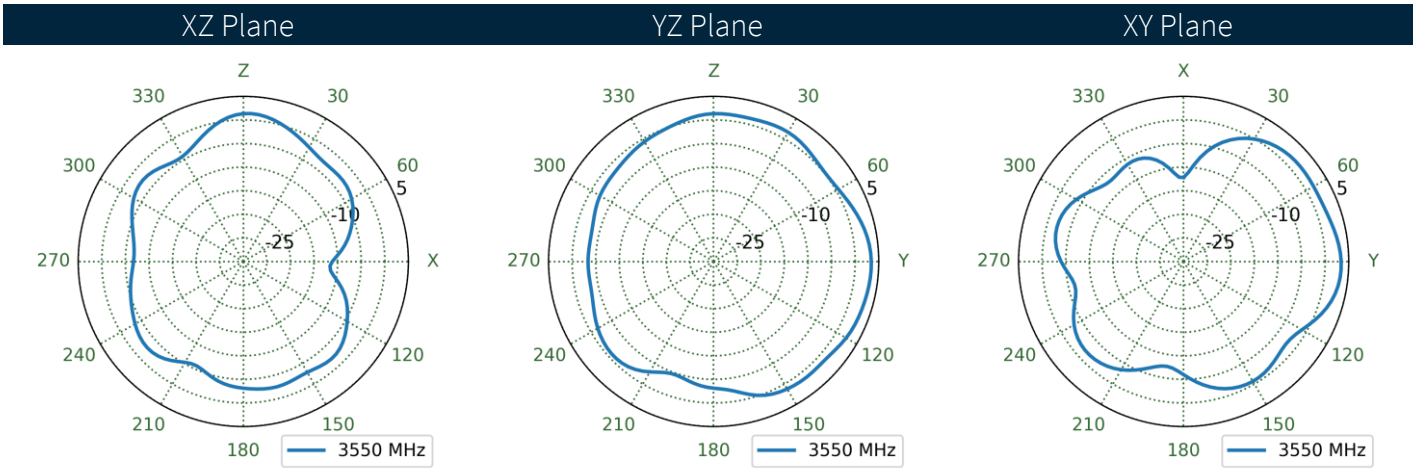
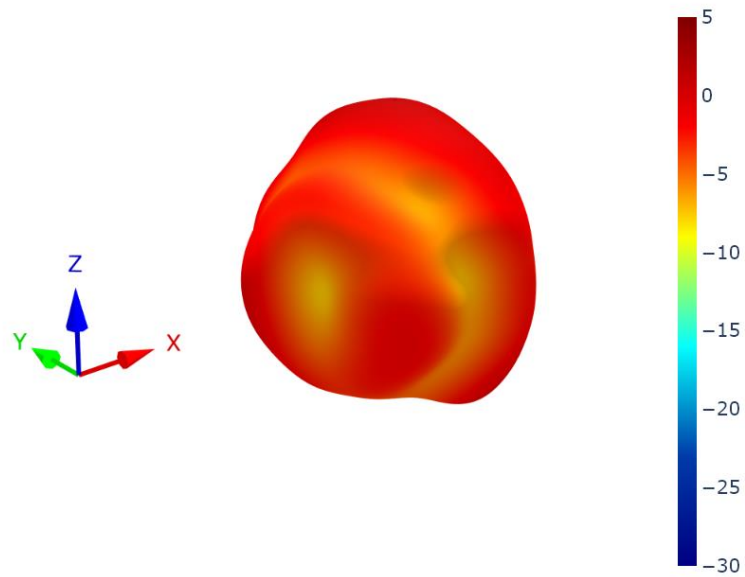

6.31 Cable Feed Straight Patterns at 3550 MHz

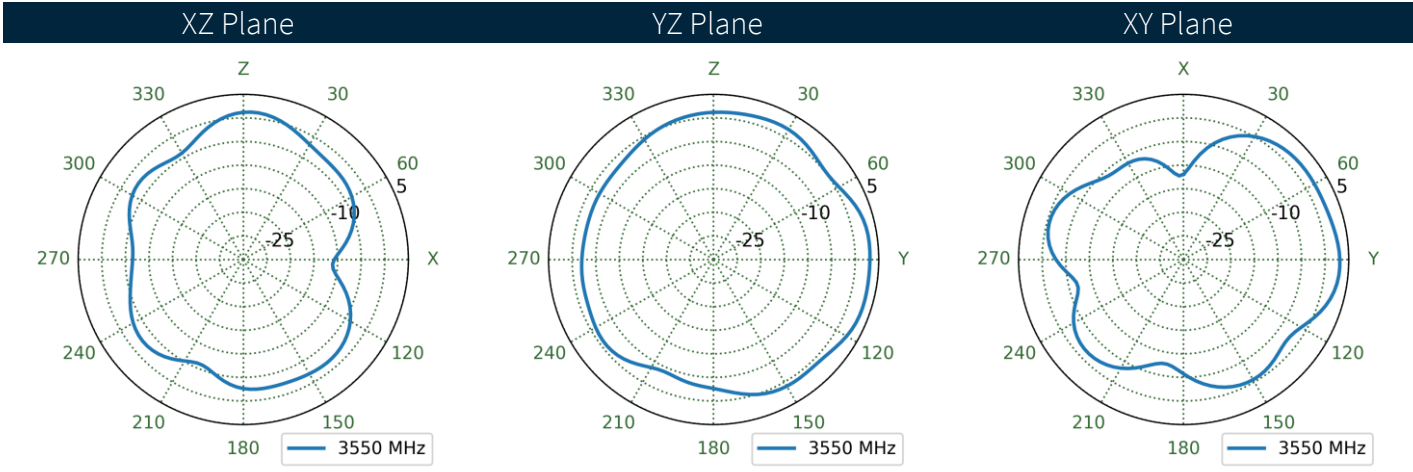
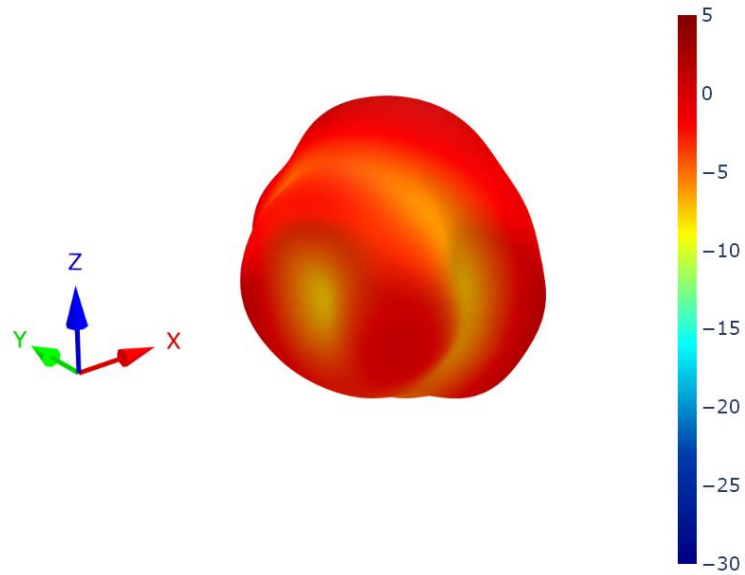

6.32 Cable Feed Left Patterns at 4600 MHz

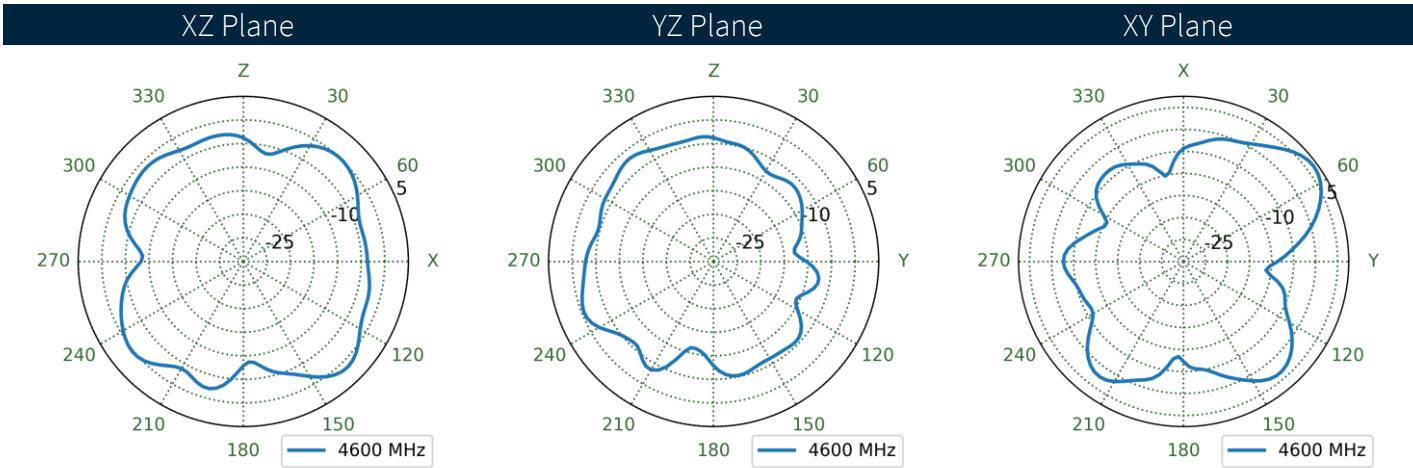
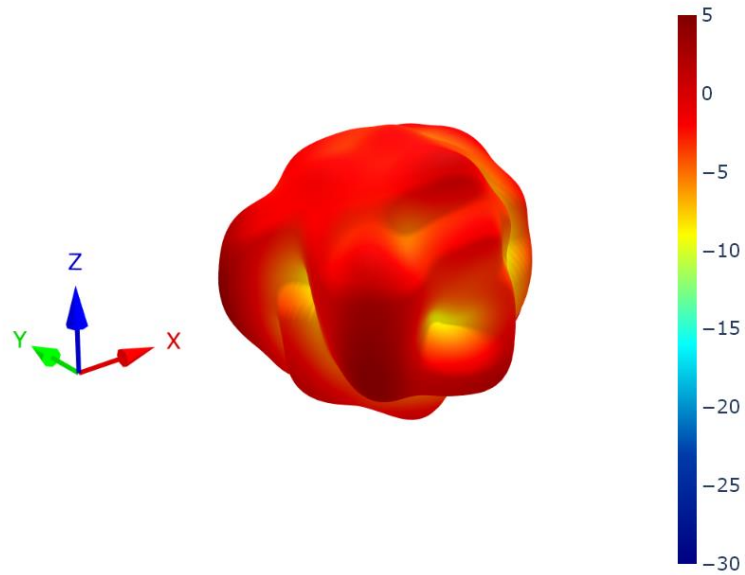

6.33 Cable Feed Right Patterns at 4600 MHz

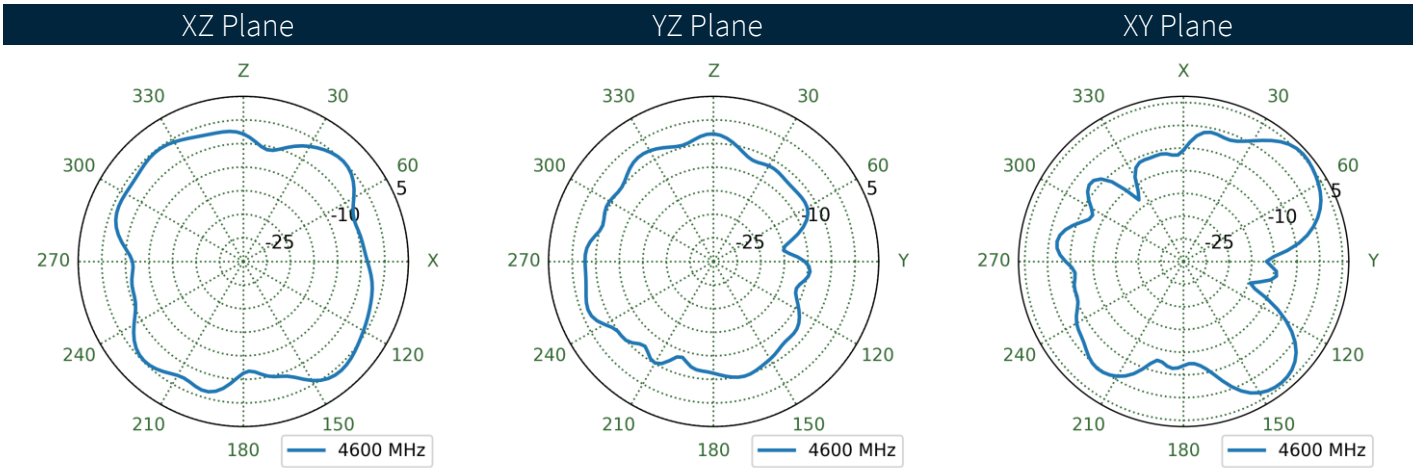
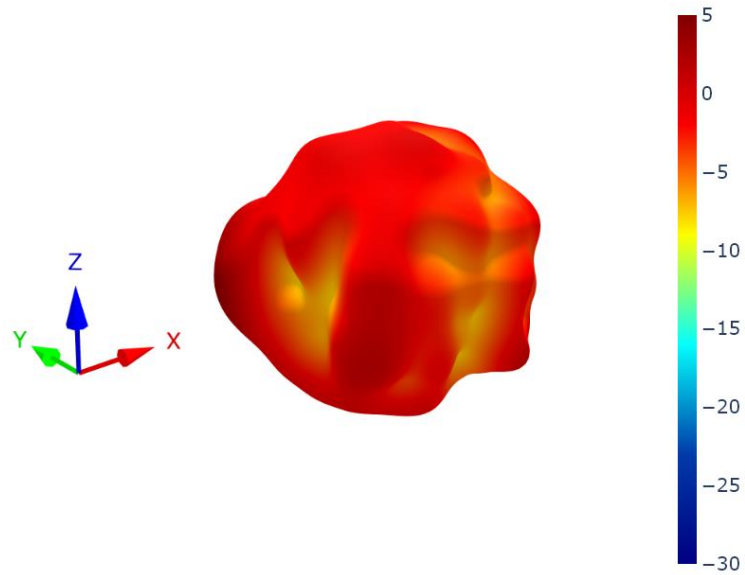

6.34 Cable Feed Straight Patterns at 4600 MHz

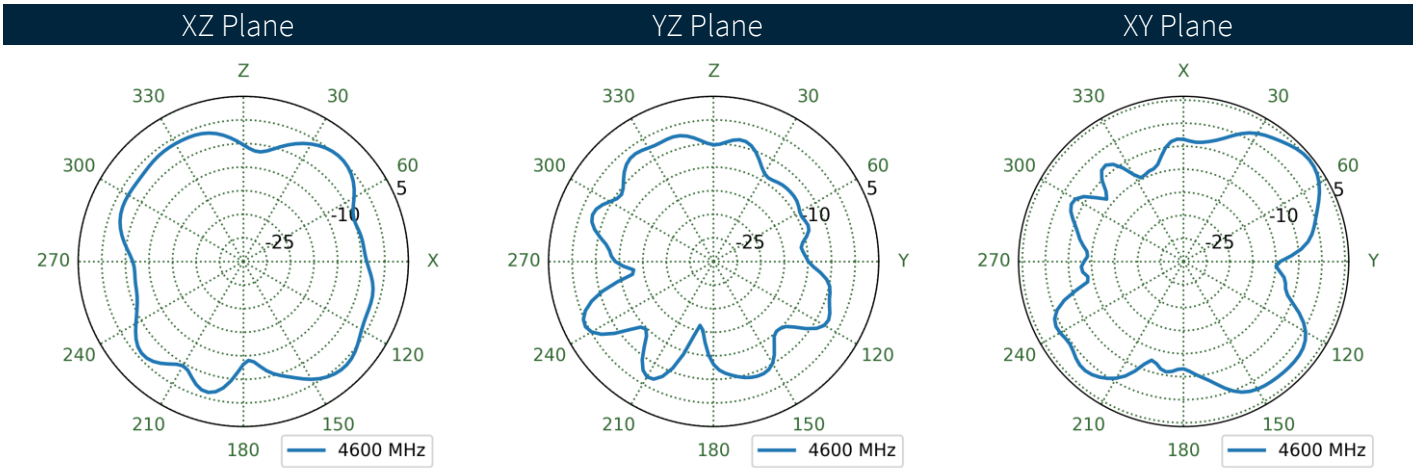
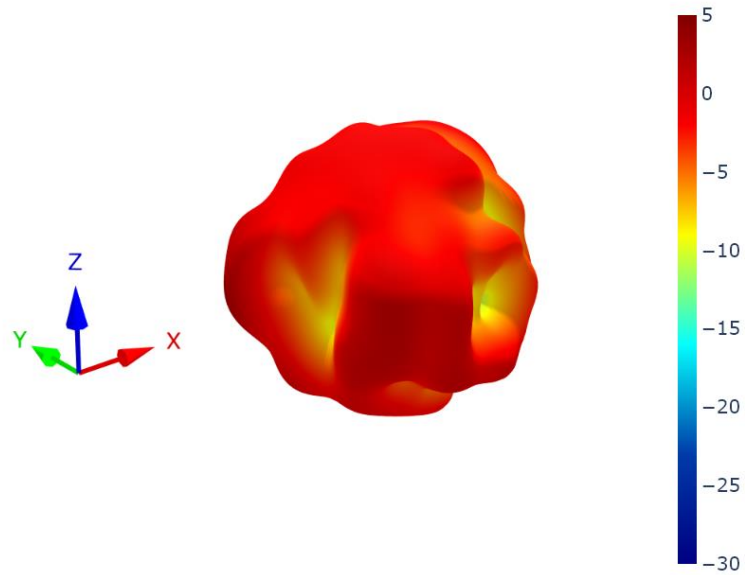

6.35 Cable Feed Left Patterns at 4800 MHz

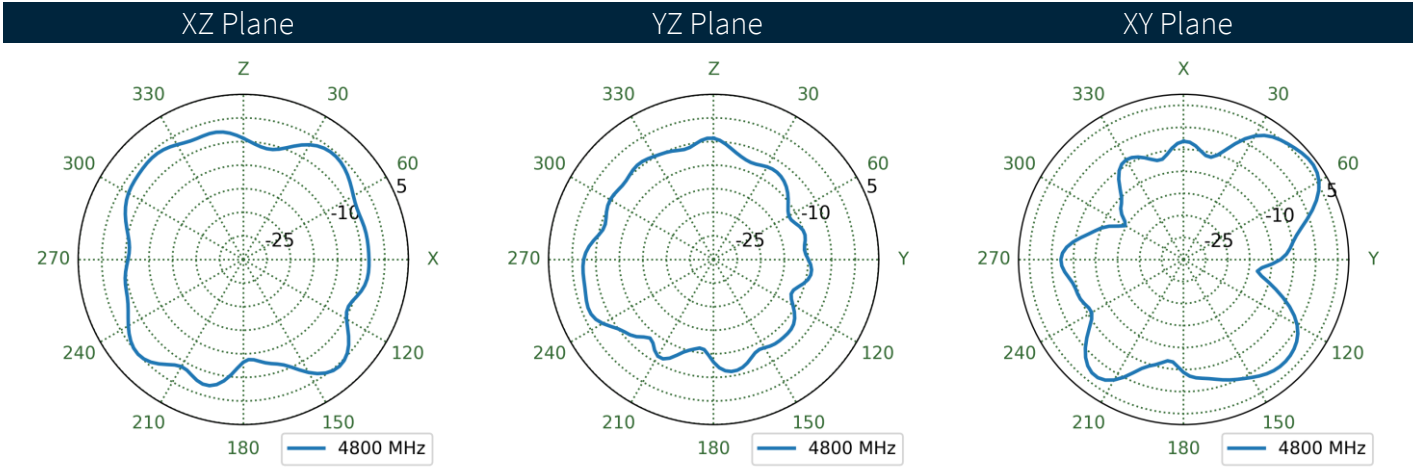
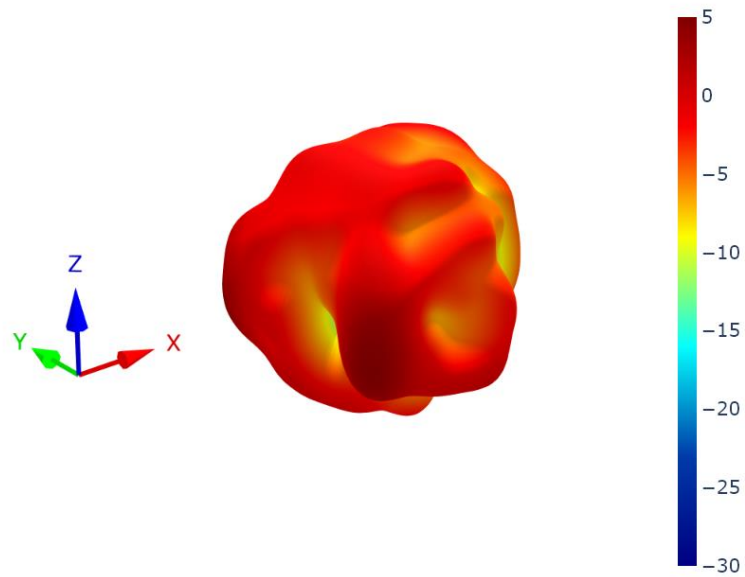

6.36 Cable Feed Right Patterns at 4800 MHz

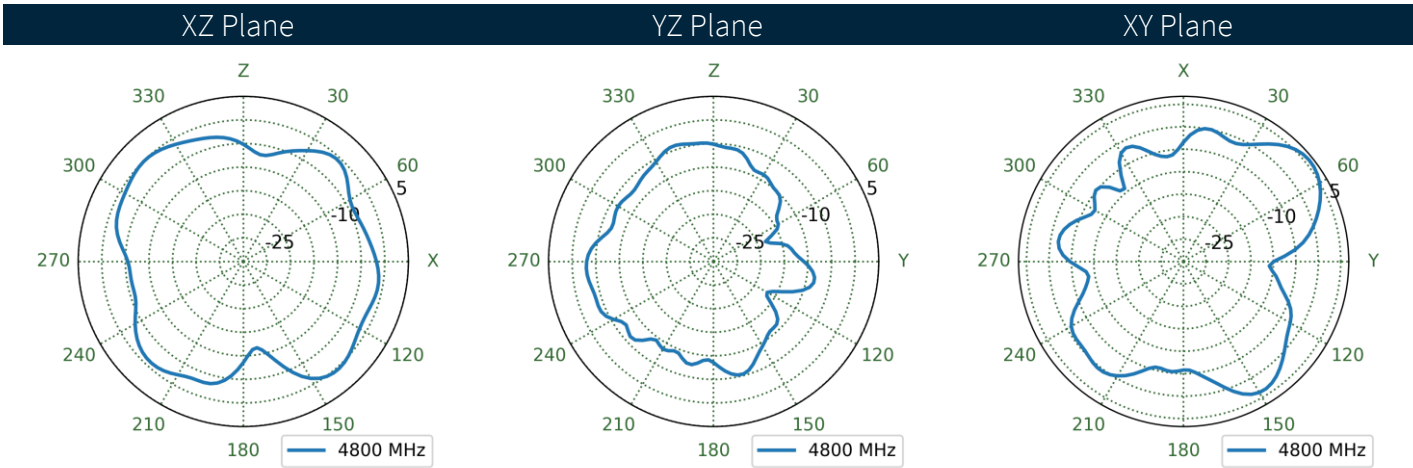
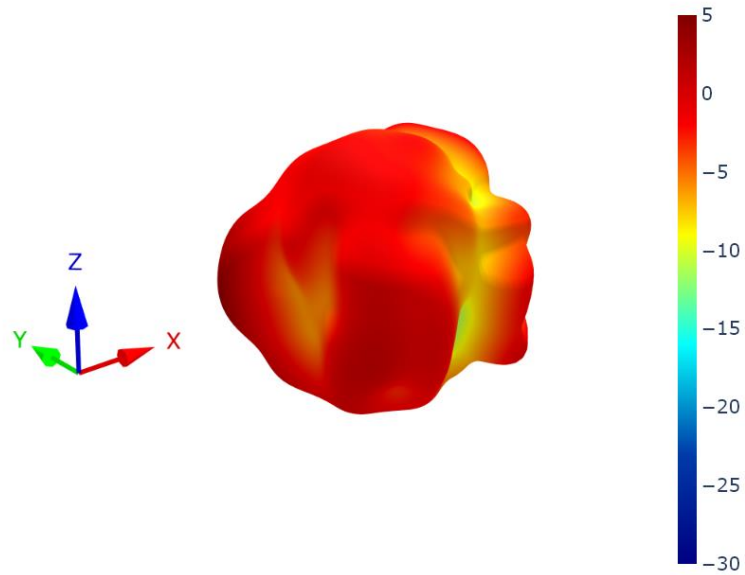

6.37 Cable Feed Straight Patterns at 4800 MHz

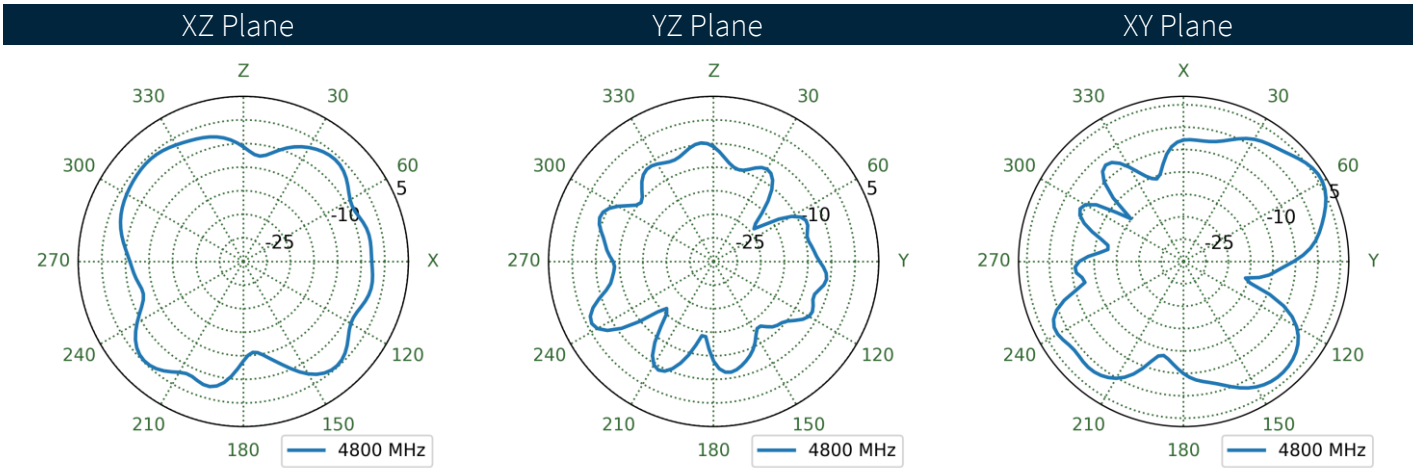
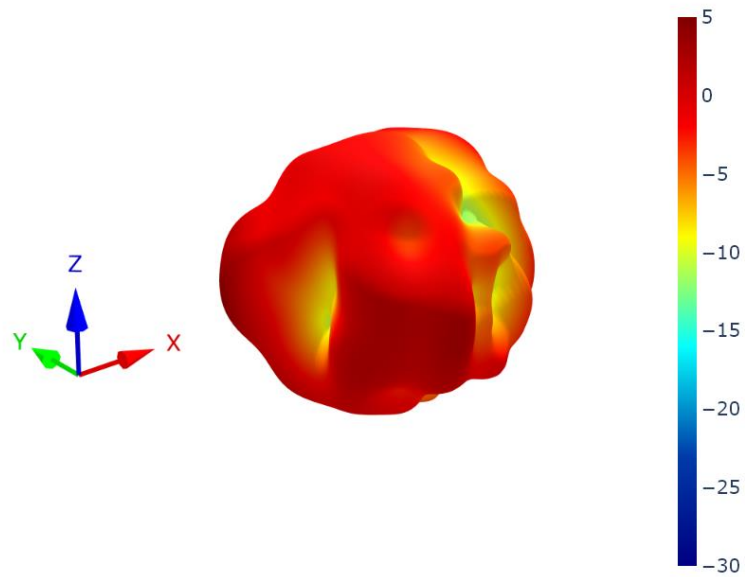

6.38 Cable Feed Left Patterns at 5530 MHz

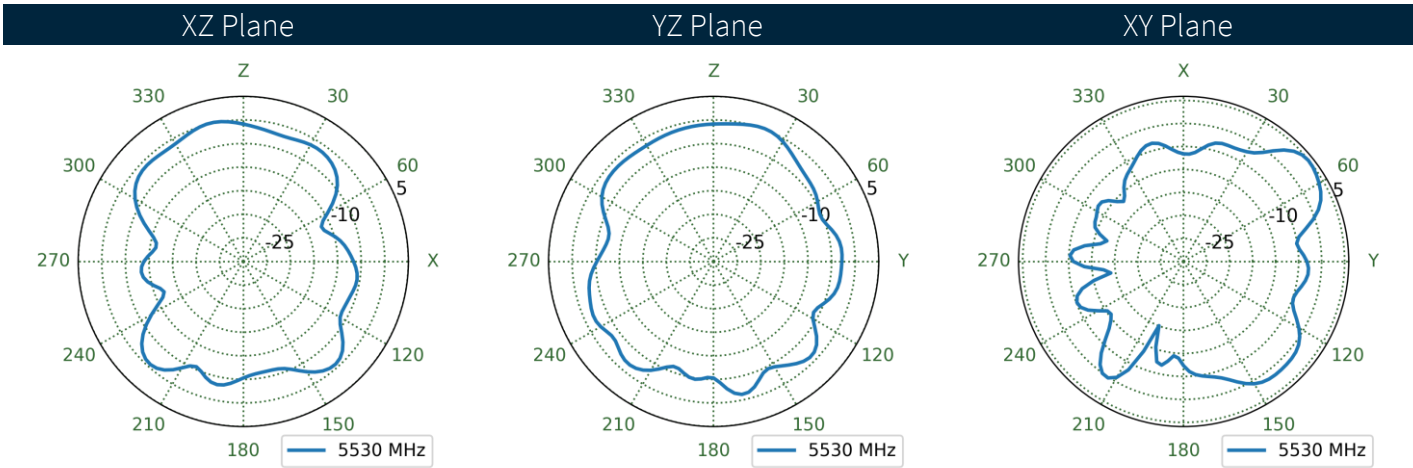
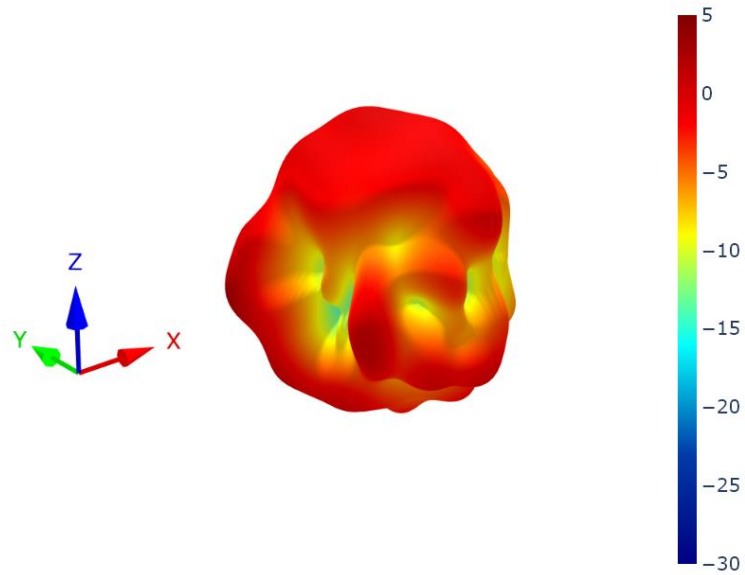

6.39 Cable Feed Right Patterns at 5530 MHz

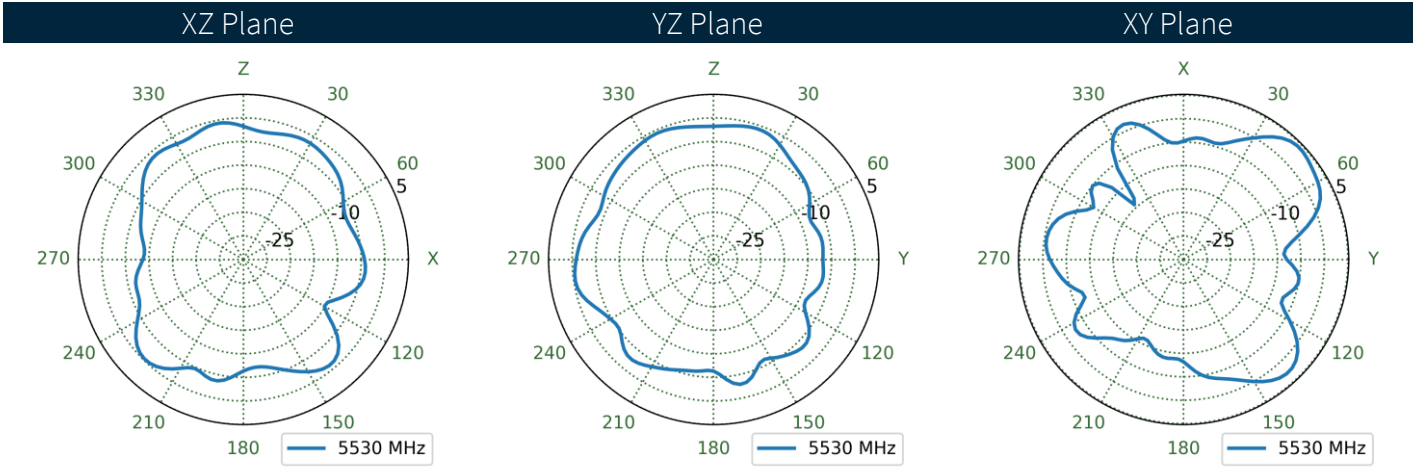
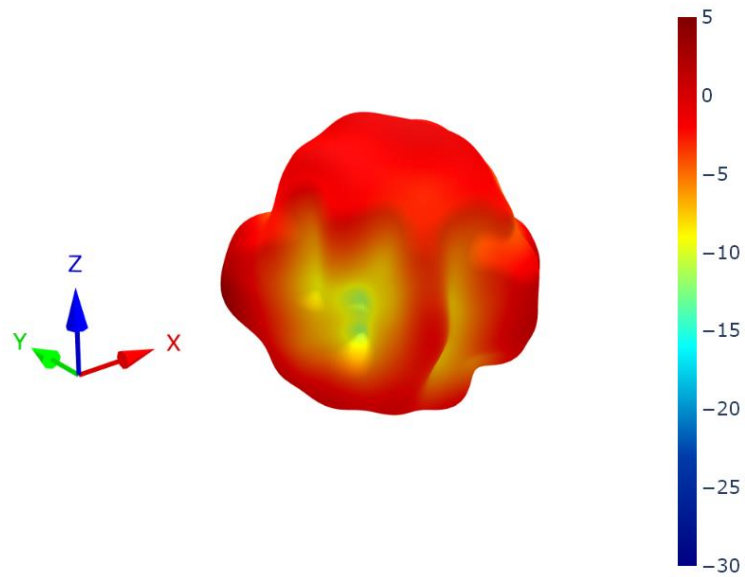

6.40 Cable Feed Straight Patterns at 5530 MHz

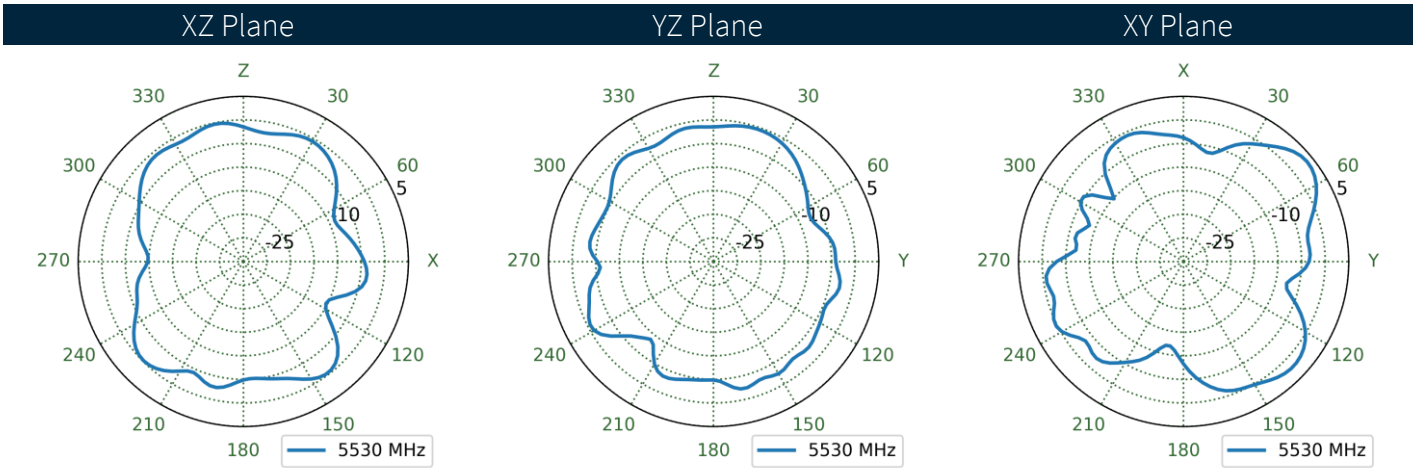
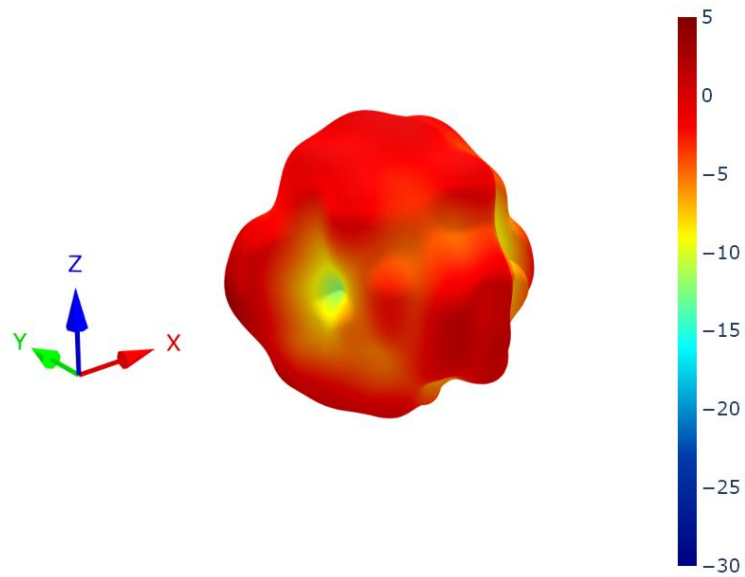

7. Application Note

This application note shows how changing the cable length affects the antenna performance.

7.1 Return Loss – Feed From Left

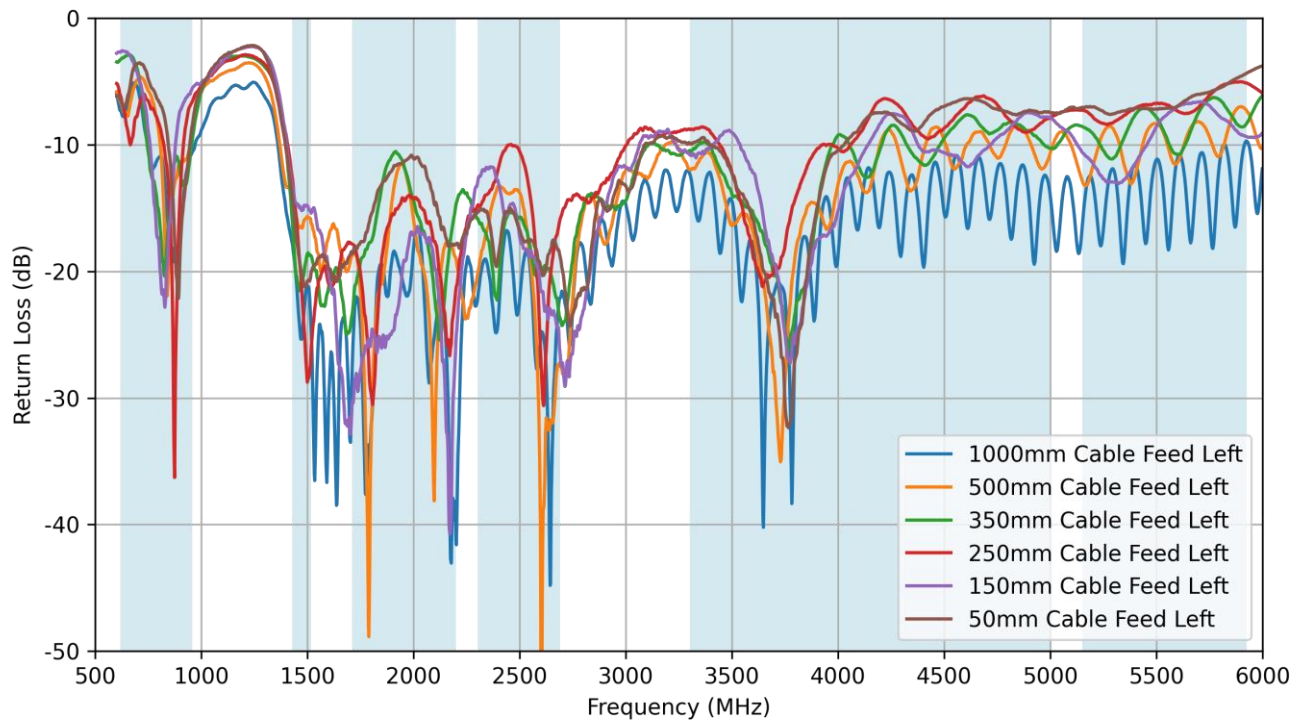

7.2 VSWR – Feed From Left

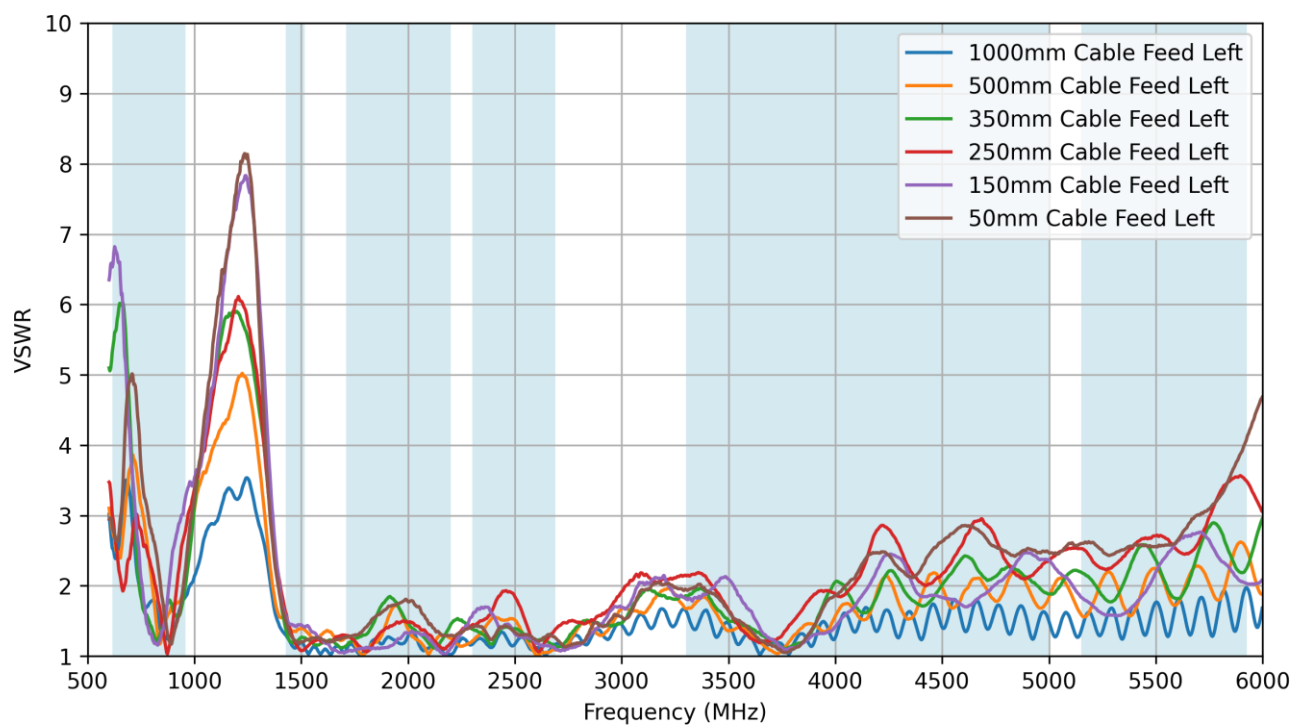

7.3 Efficiency – Feed From Left

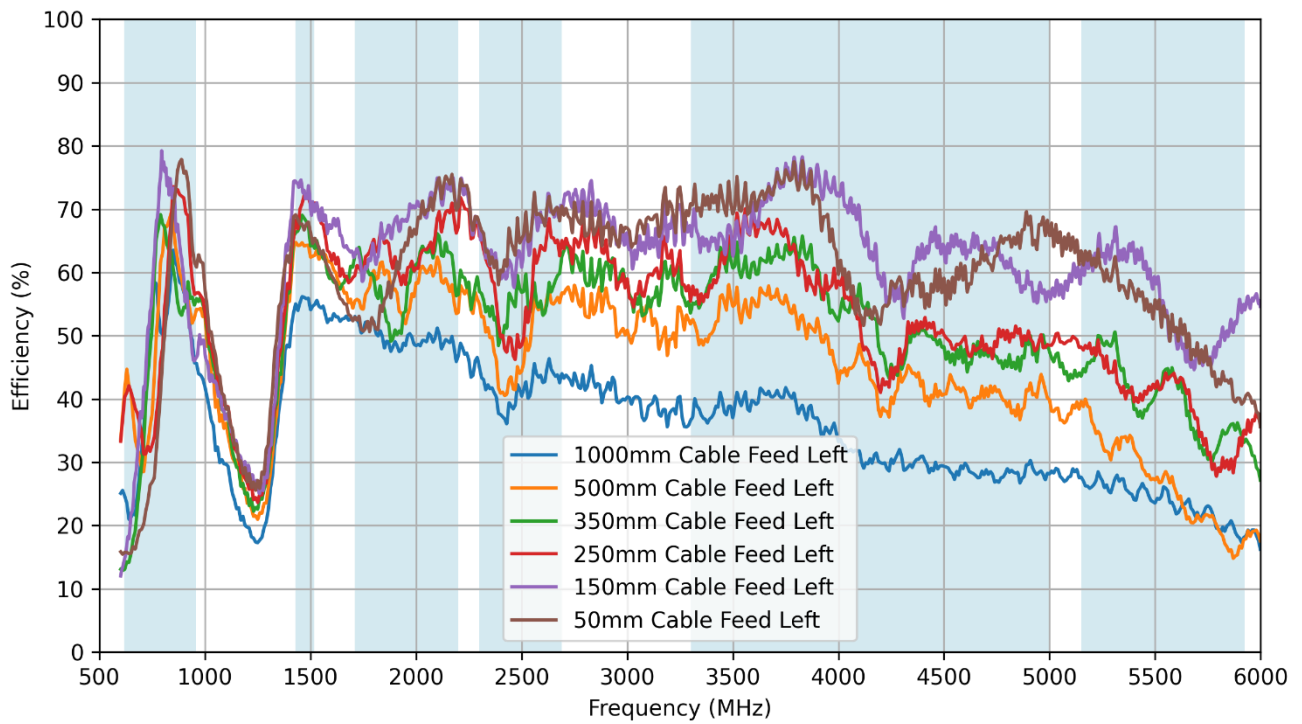

7.4 Average Gain – Feed From Left

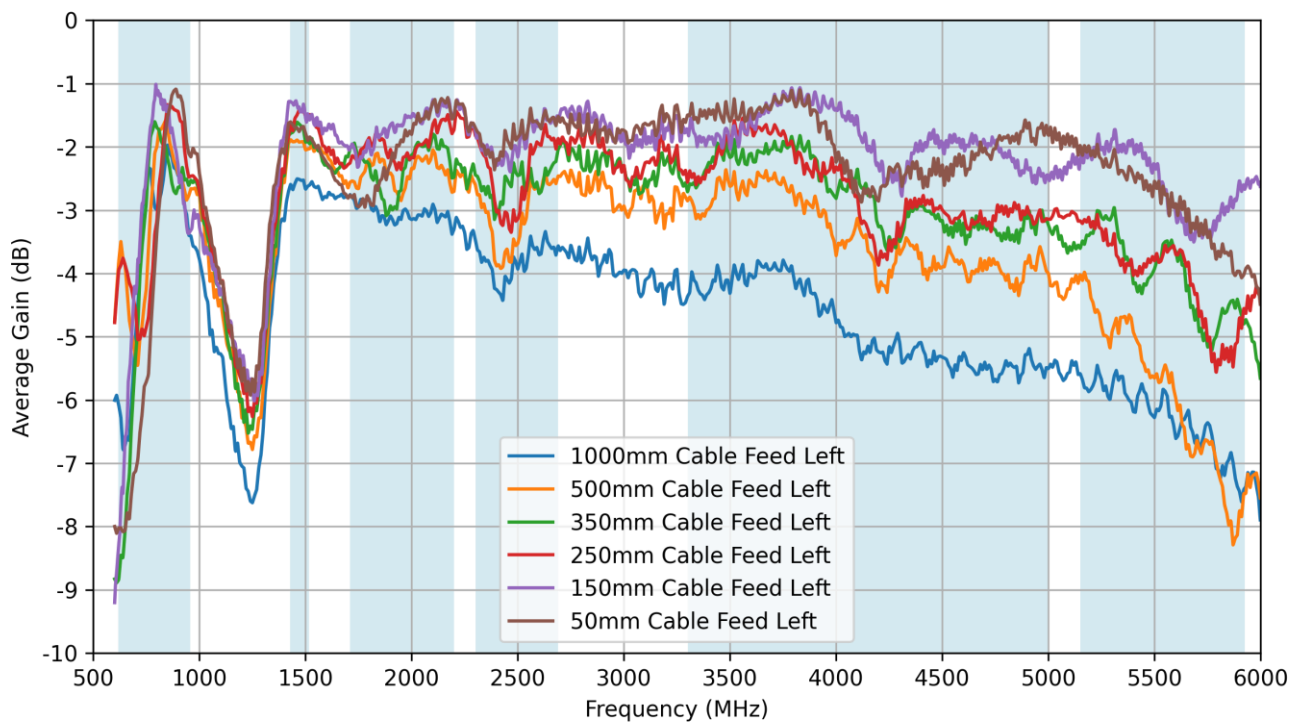

7.5 Peak Gain – Feed From Left

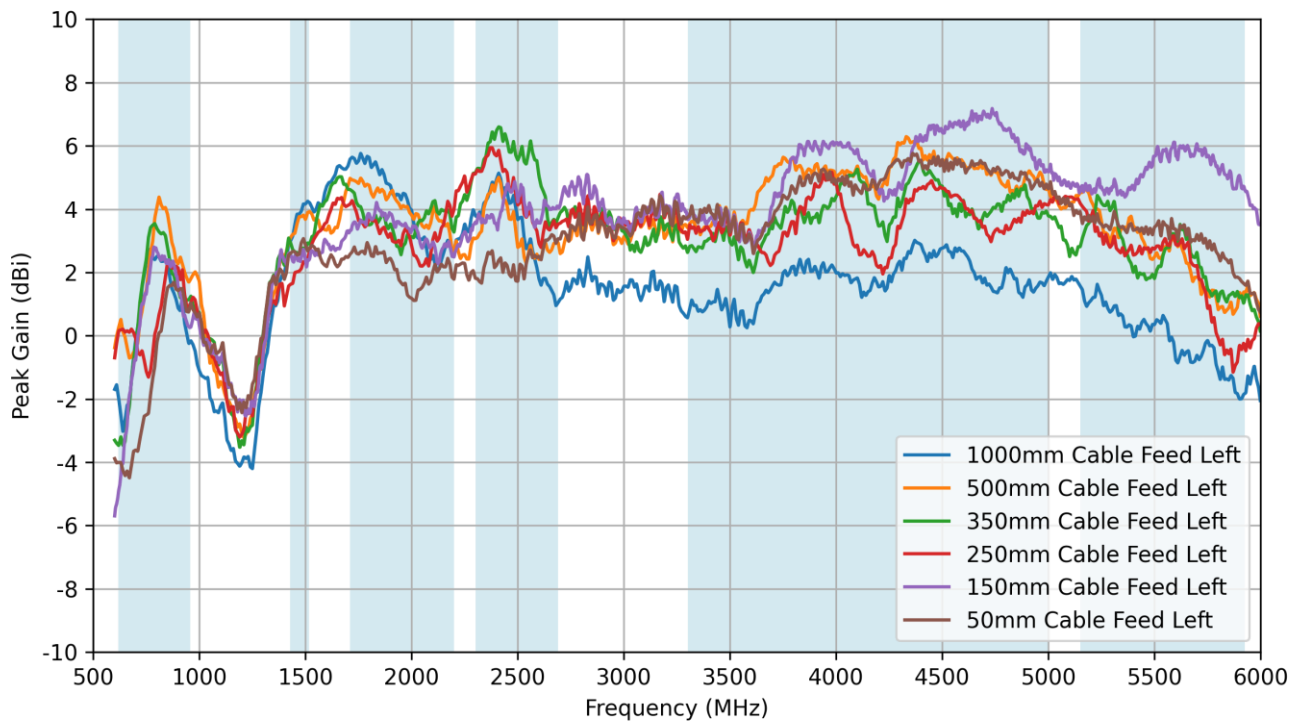

7.6 Return Loss – Feed From Right

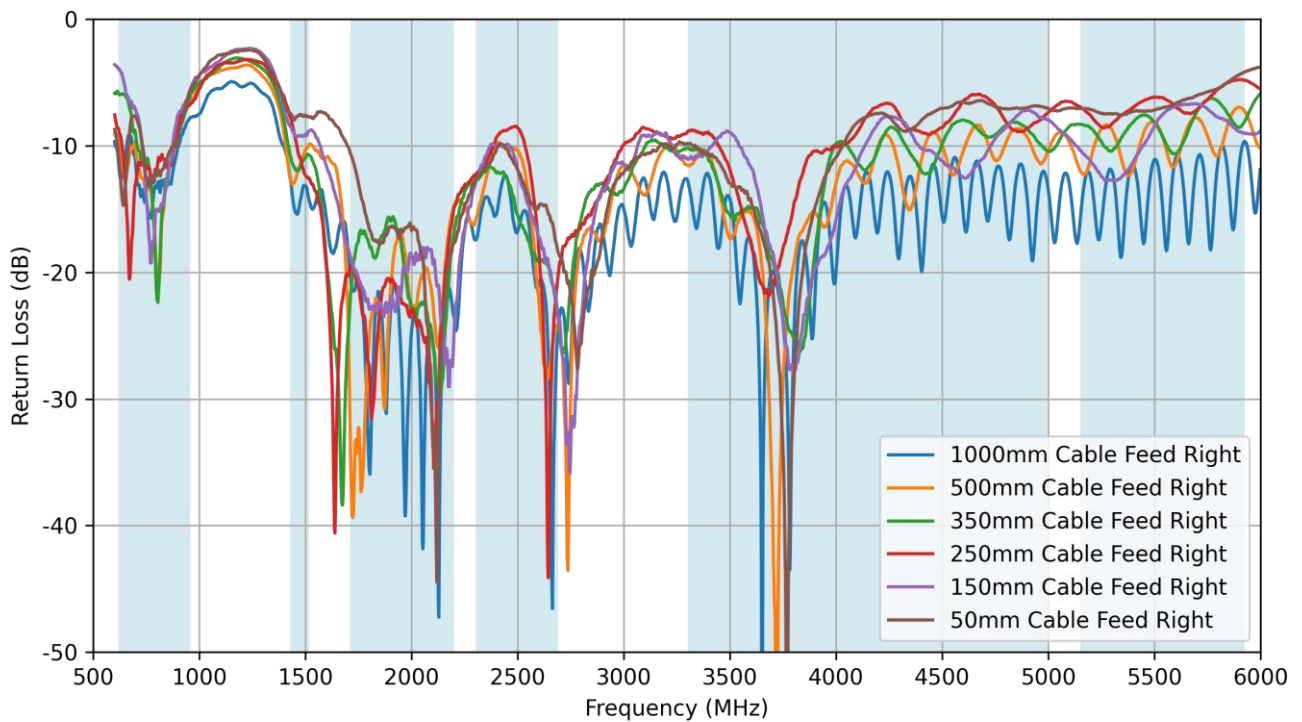

7.7 VSWR – Feed From Right

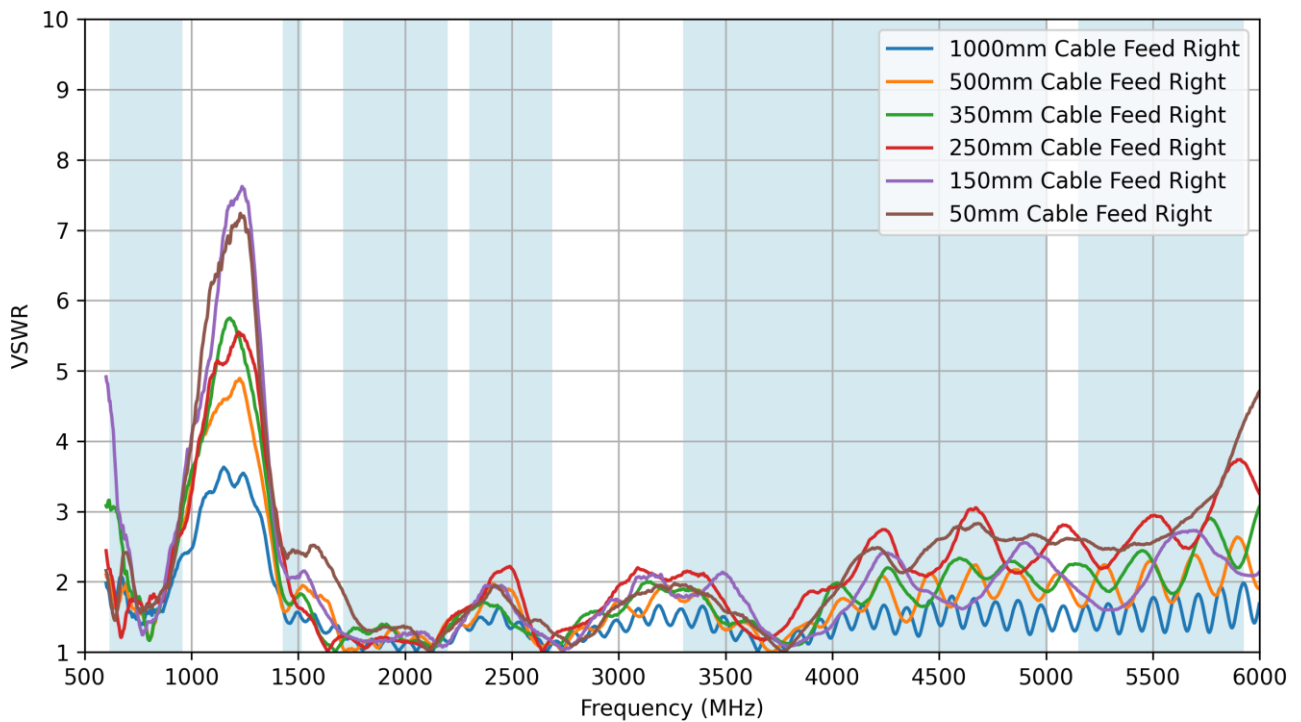

7.8 Efficiency – Feed From Right

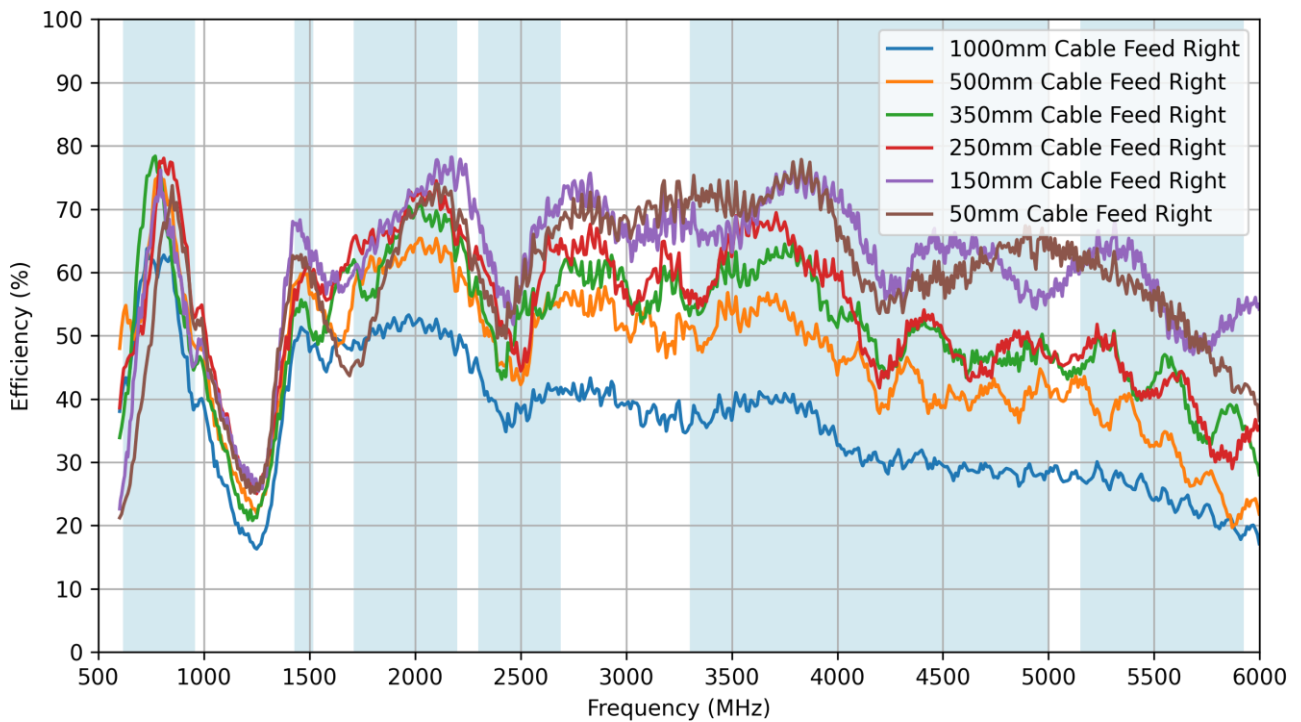

7.9 Average Gain – Feed From Right

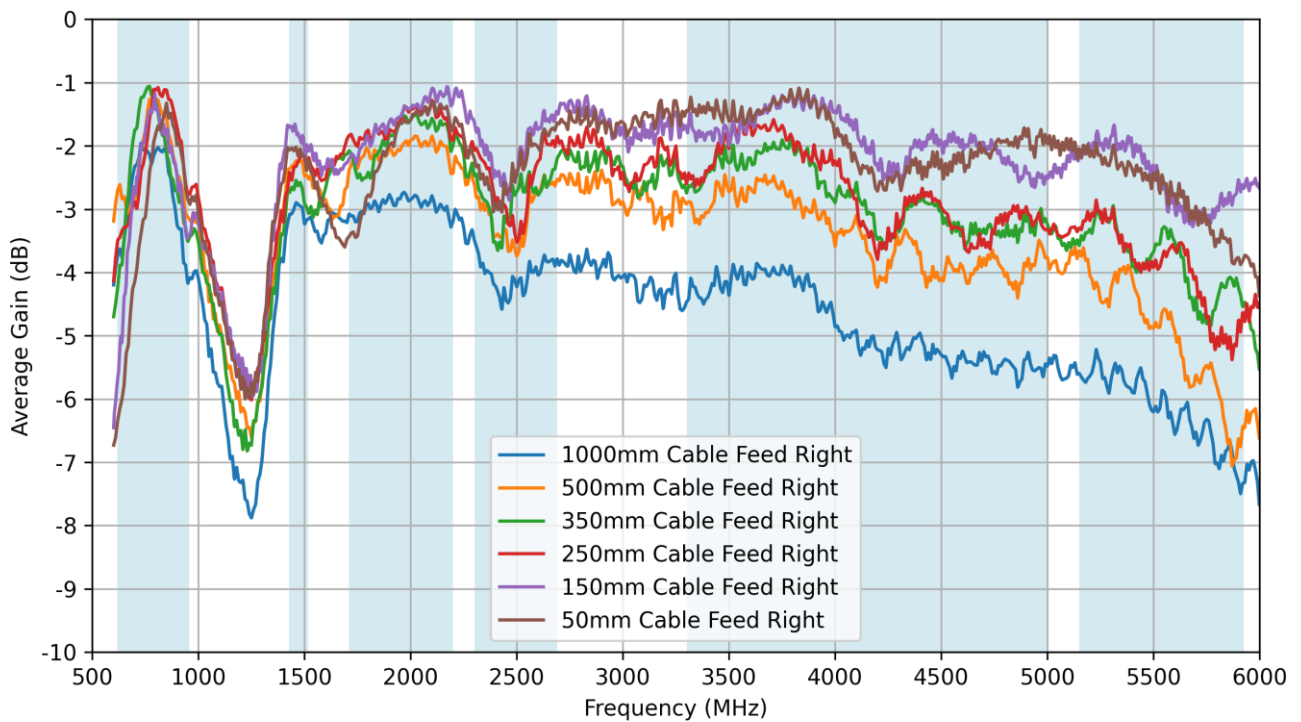

7.10 Peak Gain – Feed From Right

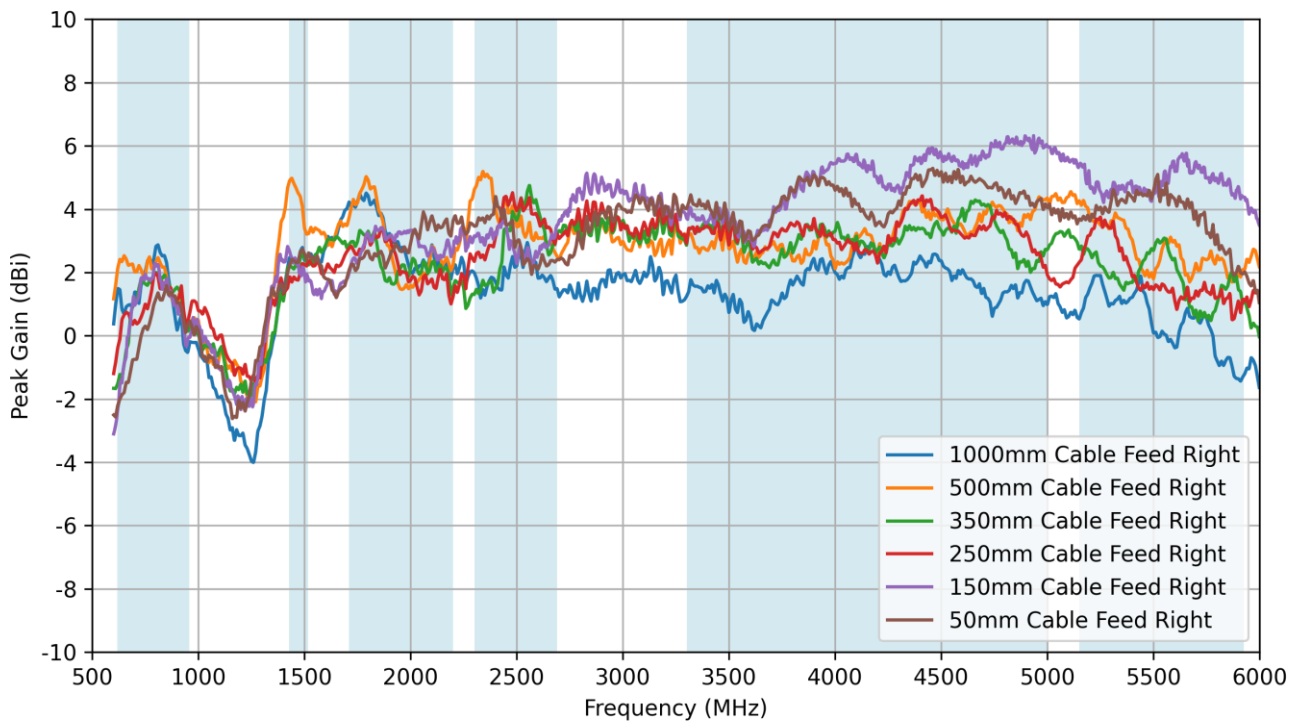

7.11 Return Loss – Feed Cable Straight

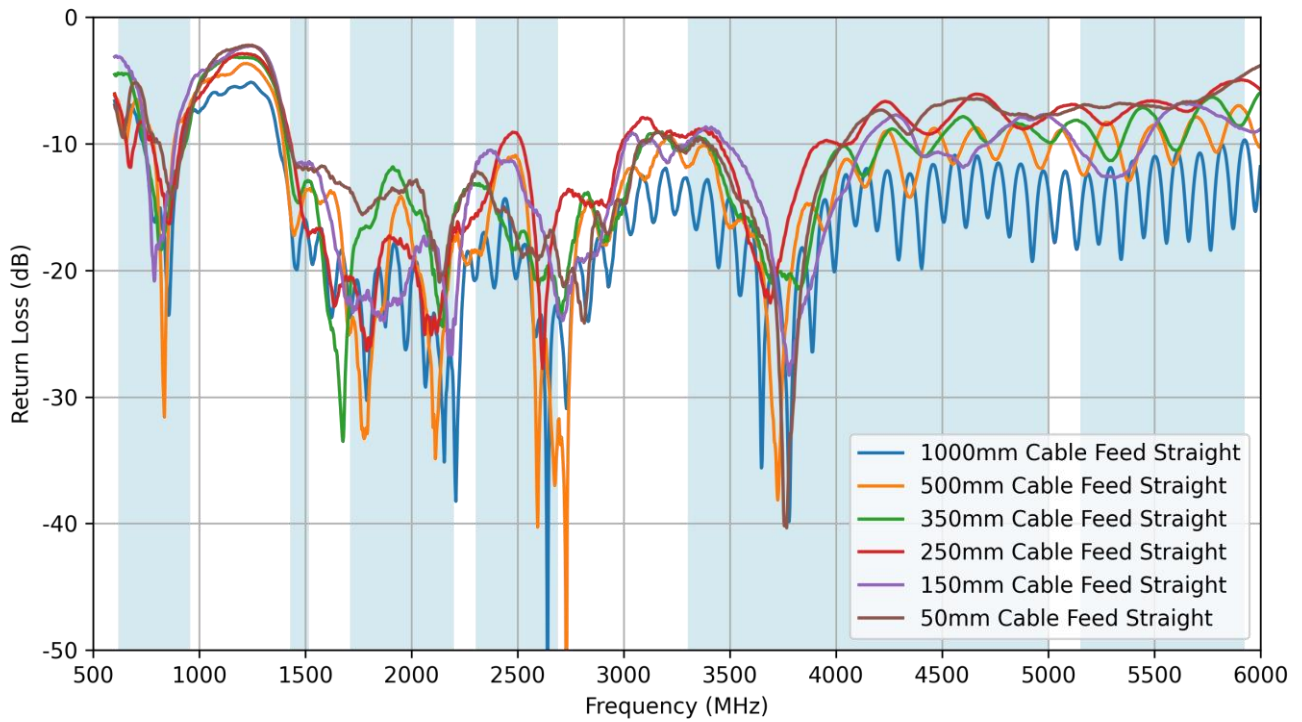

7.12 VSWR – Feed Cable Straight

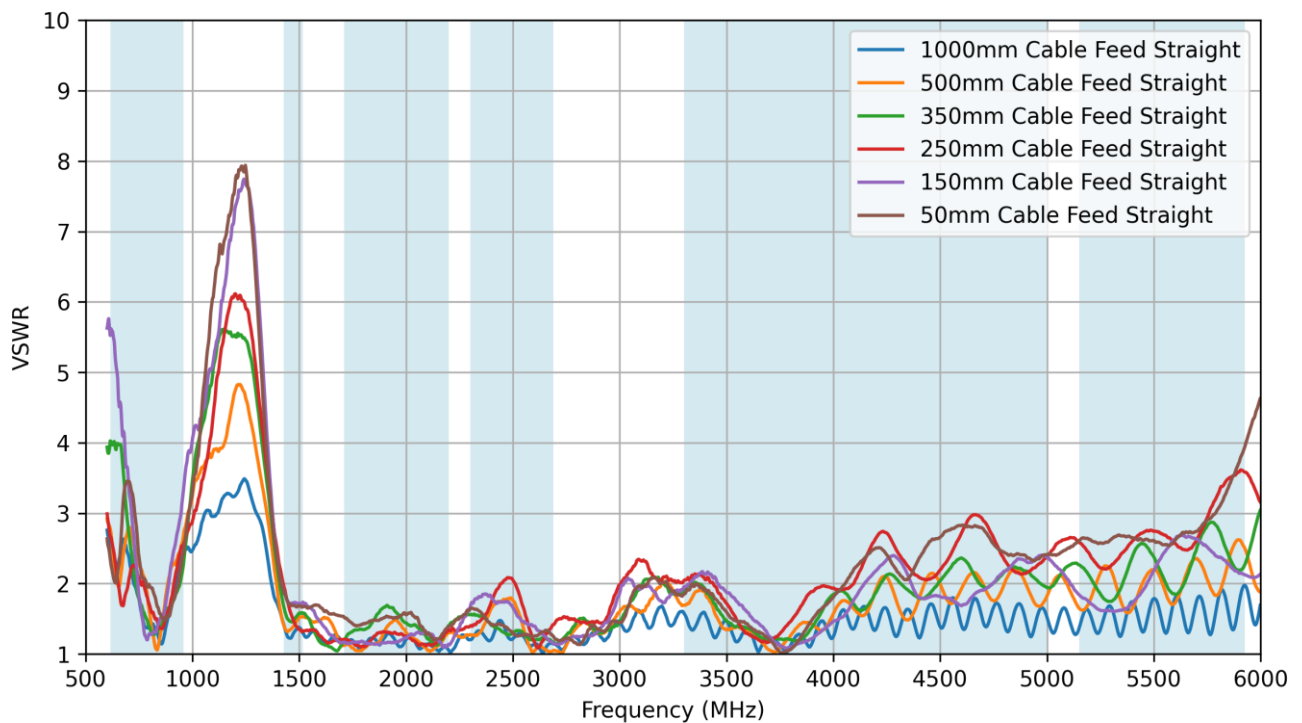

7.13 Efficiency – Feed Cable Straight

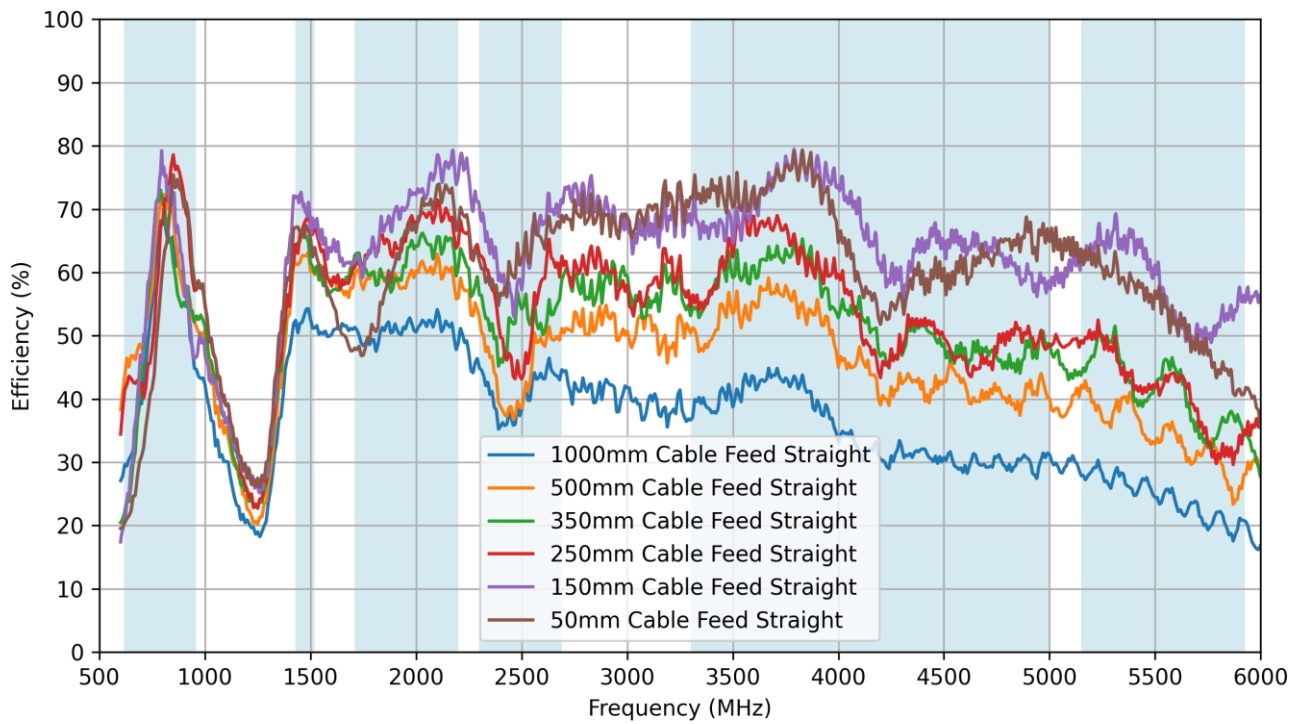

7.14 Average Gain – Feed Cable Straight

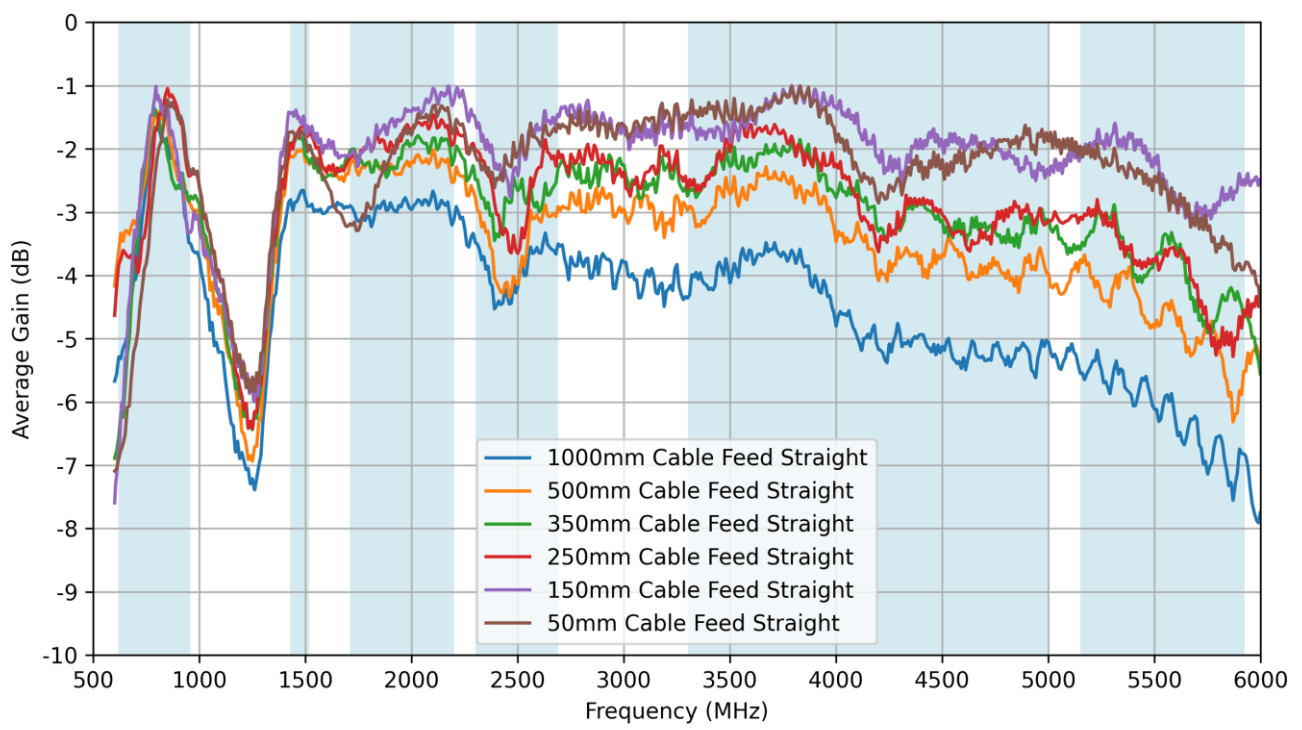

7.15 Peak Gain – Feed Cable Straight

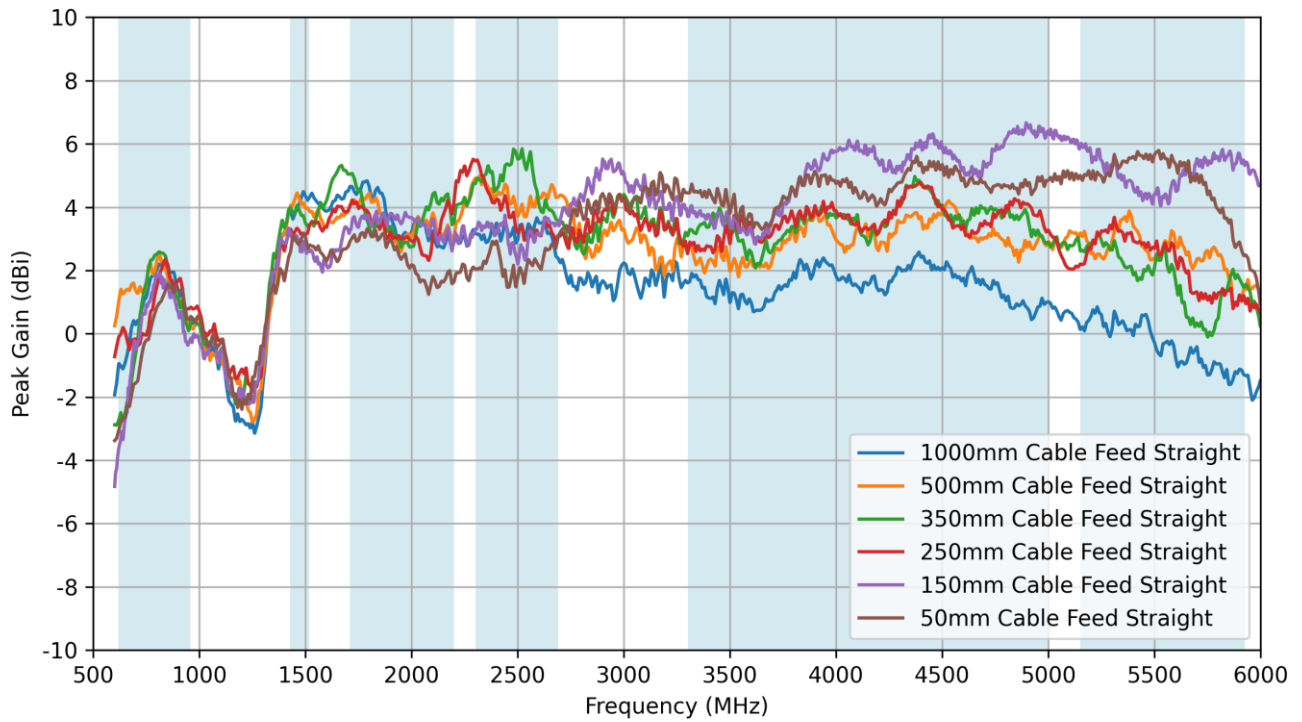

Changelog for the datasheet

SPE-24-8-126 – FXUB53.07.0150C

Revision: A (Original First Release)

Date: 2024-07-11

Notes: Initial Release

Author: Gary West

Previous Revisions



www.taoglas.com

