



TAOGLAS®



Datasheet

GPS/GLONASS/GALILEO/BeiDou Ceramic Loop

Part No:
GLA.01.A

Description

GPS/GLONASS/GALILEO/BeiDou Ceramic Loop Antenna

Features:

Low-profile SMD Antenna

Coverage:

- GPS(L1)
- GLONASS(G1)
- GALILEO(E1)
- BeiDou(B1I)

Dims: 5mm x 3mm x 2.5mm

RoHS & Reach Compliant

1.	Introduction	3
2.	Specification	4
3.	Mechanical Drawing	6
4.	Packaging	7
5.	Antenna Integration Guide	8
6.	Solder Reflow Profile	16
7.	Antenna Characteristics	17
8.	Radiation Patterns	21
<hr/>		
	Changelog	25

Taoglas makes no warranties based on the accuracy or completeness of the contents of this document and reserves the right to make changes to specifications and product descriptions at any time without notice. Taoglas reserves all rights to this document and the information contained herein. Reproduction, use or disclosure to third parties without express permission is strictly prohibited.

Ireland & USA
ISO 9001:2015
Certified



Taiwan
ISO 9001:2015
Certified



1. Introduction

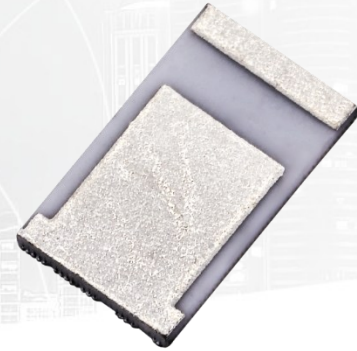

Taoglas has developed a unique ceramic miniature loop antenna series for GPS/GLONASS/GALILEO/BeiDou applications. At 5.0*3.0*0.5mm, the GLA.01 GPS/GLONASS/GALILEO/BeiDou Ceramic Loop antenna is a miniature edge mounted antenna designed for small space requirements. The radiation pattern is more omnidirectional than traditional patch antennas. The GLA loop antenna series delivers at least three times the efficiency of traditional linearly polarized 1575.42 MHz antennas, reaching efficiencies of up to 75%.

Mechanically, the GLA.01 at only 0.5mm in height has a very low profile, and with a footprint of 6.0 x 5.5mm needs less space on the board. It does require clearance of 6.0 x 5.5mm. Based on the loop effect, this antenna works best when placed on the center of the edge of the board, but can still work better than traditional linear polarized chip antennas even when placed at corners as a substitute.

The GLA.01 is delivered on tape and reel and now allows M2M customers to use an omni-directional antenna in devices where orientation of the product is unknown.

This antenna can be mounted with no performance degradation in either orientation as long as the antenna is soldered correctly via Surface mounting. Please see the integration instructions section for further detail regarding the optimum way to integrate this antenna into your device.

For further optimization to customer-specific device environments and for support to integrate and test this antennas performance in your device, contact your regional Taoglas Customer Services Team.

Applications:

Navigation or position tracking systems

Hand-held devices when GPS/GLONASS/GALILEO/BeiDou function is needed, e.g., smart phone. PDA

2. Specification

GNSS Frequency Bands					
GPS	L1 1575.42 MHz	L2 1227.6 MHz	L5 1176.45 MHz		
	■	□	□		
GLONASS	G1 1602 MHz	G2 1248 MHz	G3 1207 MHz		
	■	□	□		
Galileo	E1 1575.24 MHz	E5a 1176.45 MHz	E5b 1201.5 MHz	E6 1278.75 MHz	
	■	□	□	□	
BeiDou	B1C 1575.42 MHz	B1I 1561 MHz	B2a 1176.45 MHz	B2b 1207.14 MHz	B3 1268.52 MHz
	■	■	□	□	□
L-Band	L-Band 1542 MHz				
	□				
QZSS (Regional)	L1 1575.42 MHz	L2C 1227.6 MHz	L5 1176.45 MHz	L6 1278.75e6	
	■	□	□	□	
IRNSS (Regional)	L5 1176.45 MHz				
	□				
SBAS	L1/E1/B1 1575.42 MHz	L5/B2a/E5a 1176.45 MHz	G1 1602 MHz	G2 1248 MHz	G3 1207 MHz
	■	□	■	□	□

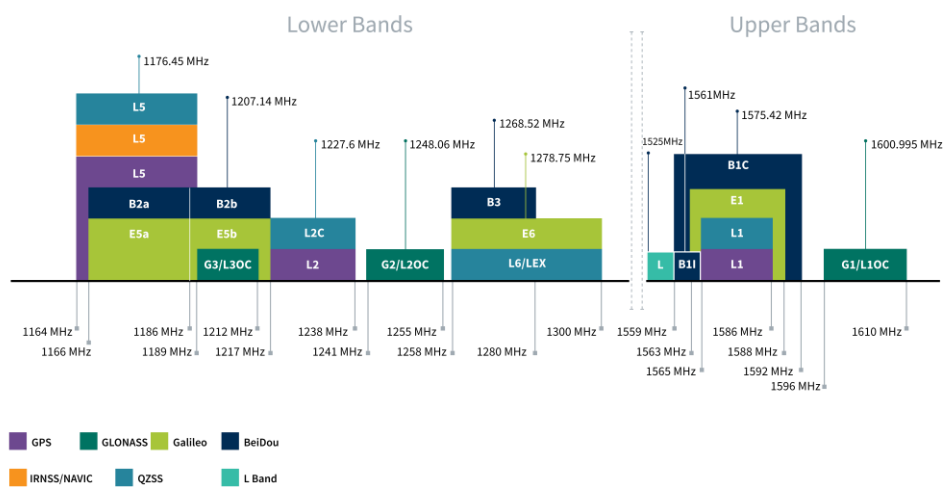

GNSS Bands and Constellations

GNSS Electrical			
Frequency (MHz)	1561	1575.42	1603
VSWR (max.)	1.5:1	1.5:1	2:1
Efficiency (%)	74.0	75.9	70.5
Average Gain (dB)	-1.32	-1.19	-1.51
Peak Gain (dBi)	3.51	3.55	3.50
Polarization	Linear		
Impedance	50 Ω		
Connector	SMA(M)		

Mechanical	
Dimensions	5 x 3x 2.5mm
Material	Ceramic
Connector	SMA(M)

Environmental	
Operation Temperature	-40°C to 85°C
Storage Temperature	-40°C to 105°C
Temperature Coefficient (τf)	0 \pm 20 ppm @-20° C to +80° C
Recommended Reel Storage Condition	5°C to 40°C Relative Humidity 20% to 70%
Moisture Sensitivity (MSL)	Level 3 (168 Hours)

3. Mechanical Drawing

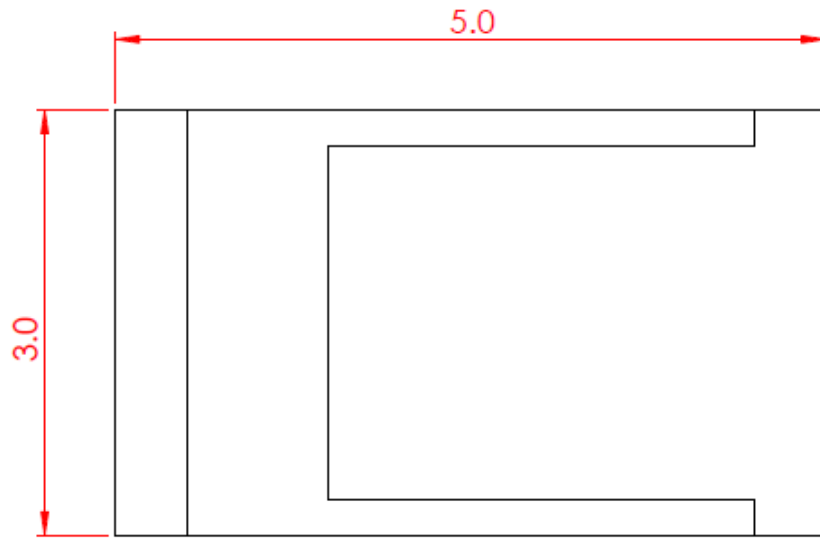

Top View

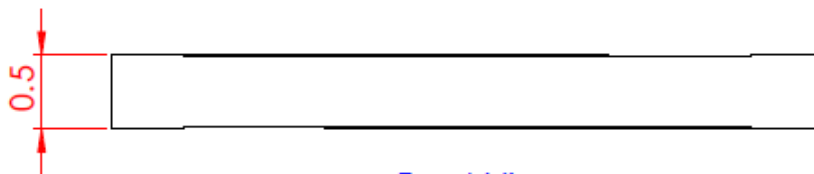

Front View

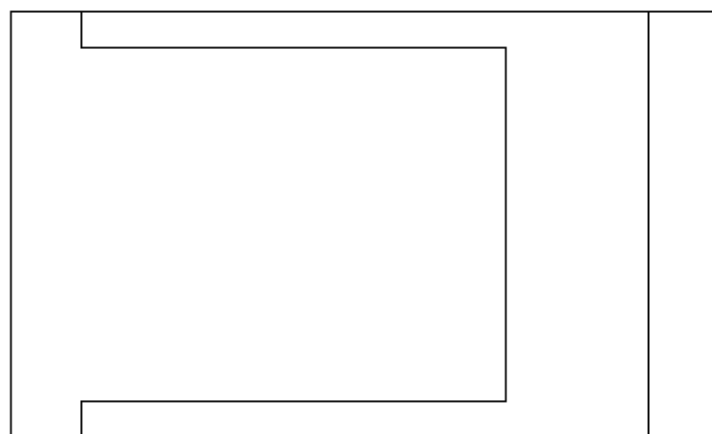

Bottom View

4. Packaging

6000pcs GLA.01 per Tape and Reel
 Dimensions: Ø330 x 60mm

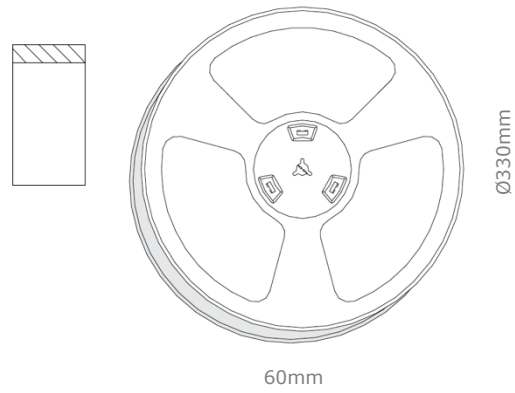

6000pcs GLA.01 per Carton
 Dimensions: 340 x 340 x 90mm

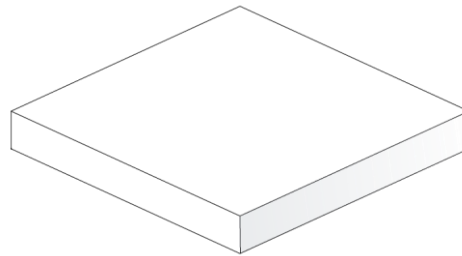

5. Antenna Integration Guide

The following is an example on how to integrate the GLA.01 into a design. This antenna has 3 pins, where one pin is used for the RF Feed. Taoglas recommends using a minimum of 80x40mm ground plane (PCB) to ensure optimal performance.

The antenna should be placed mid-point on the long side of the PCB to take advantage of the ground plane on each side of the antenna.



Top view of PCB.



Top view of PCB reference design.

Please find the Integration files in Altium, 2D formats and the 3D model for the GLA.01 here:
<https://www.taoglas.com/product/gla-01-gps-ceramic-loop-antenna-2/>

5.1 Schematic and Symbol Definition



Above is a 3D model of the GLA.01 on a PCB.

The circuit symbol for the GLA.01 is shown below. The antenna has 3 pins as indicated below.

Pin	Description
1	RF Feed
2	Ground
3	Fine Tuning Element

TAOGLAS_GLA.01
ANT1

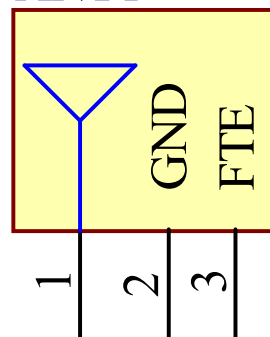

Above is a schematic symbol of GLA.01 and a table of the pin definitions.

5.2 Antenna Footprint

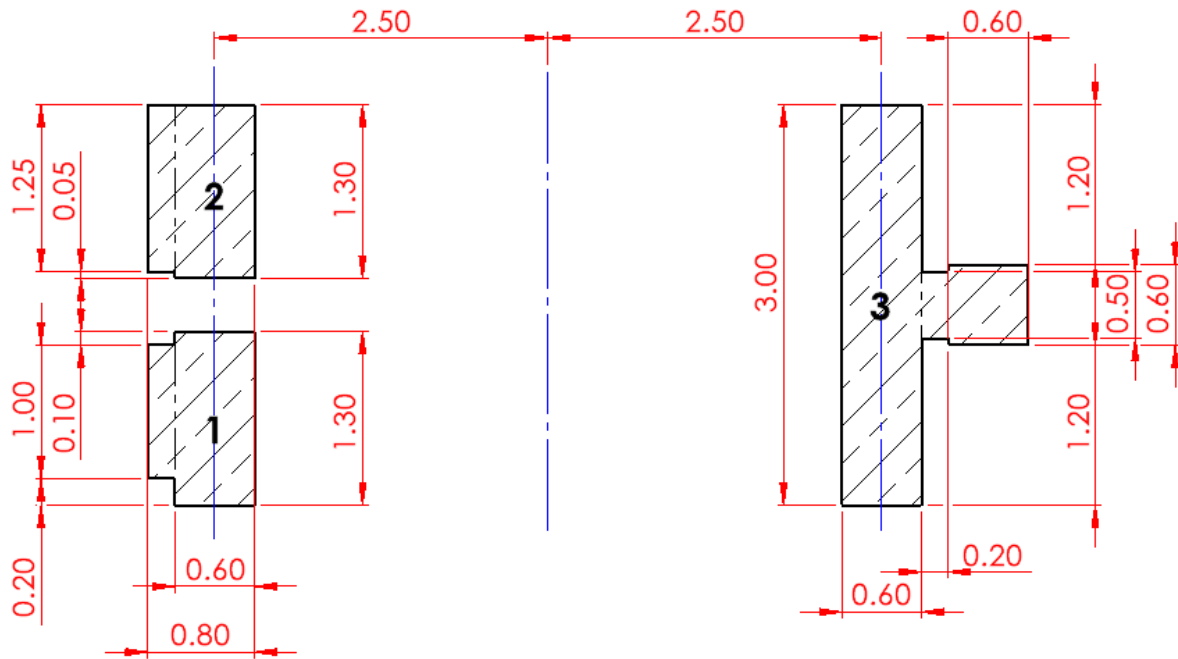

Pin	Description
1	RF Feed
2	Ground
3	Fine Tuning Element

5.3 Top Solder Paste

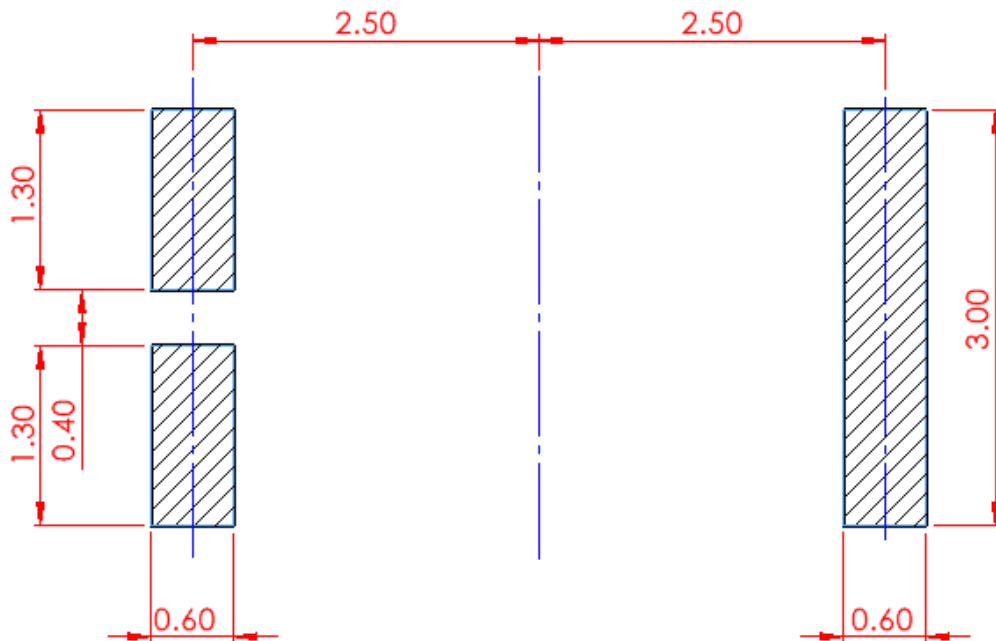

5.4 Top Solder Paste

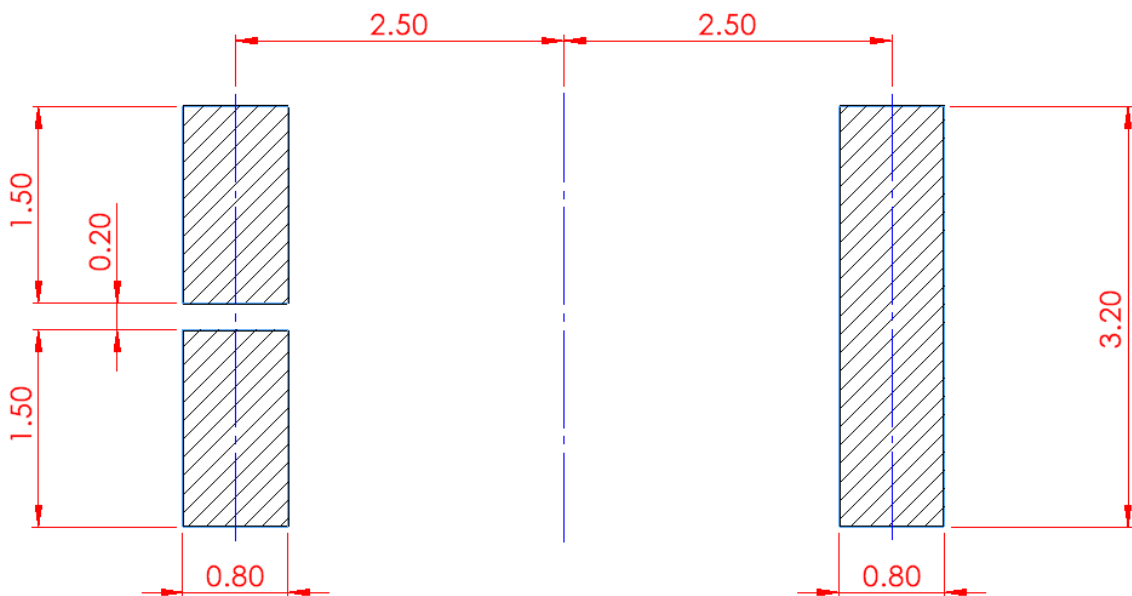

5.5 Copper Clearance for GLA.01

The footprint and clearance on the PCB must comply with the antenna's specification. The PCB layout shown in the diagrams below demonstrates the GLA.01 clearance area. The copper keep-out area applies to all layers on the PCB.

The copper clearance area extends to 7.1mm in length and 5.5mm in width around the antenna. The PCB edge clearance should be a minimum of 0.1mm, example below is 0.2mm.

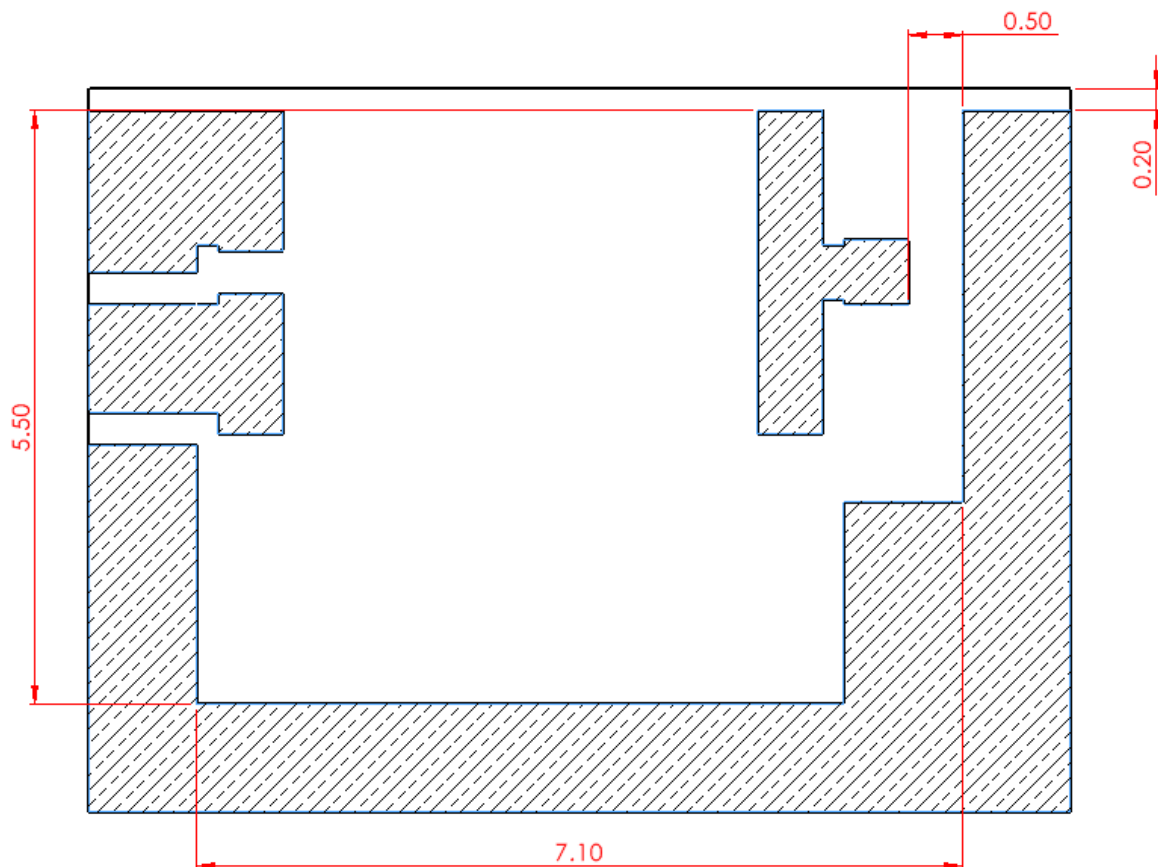

5.6 Schematic Layout

Matching components with the GLA.01 are required for the antenna to have optimal performance in the spaces specified in the schematic below. Additional matching components may be necessary for your device, Taoglas recommends incorporating extra component footprints, forming a “pi” network, for the GLA.01.

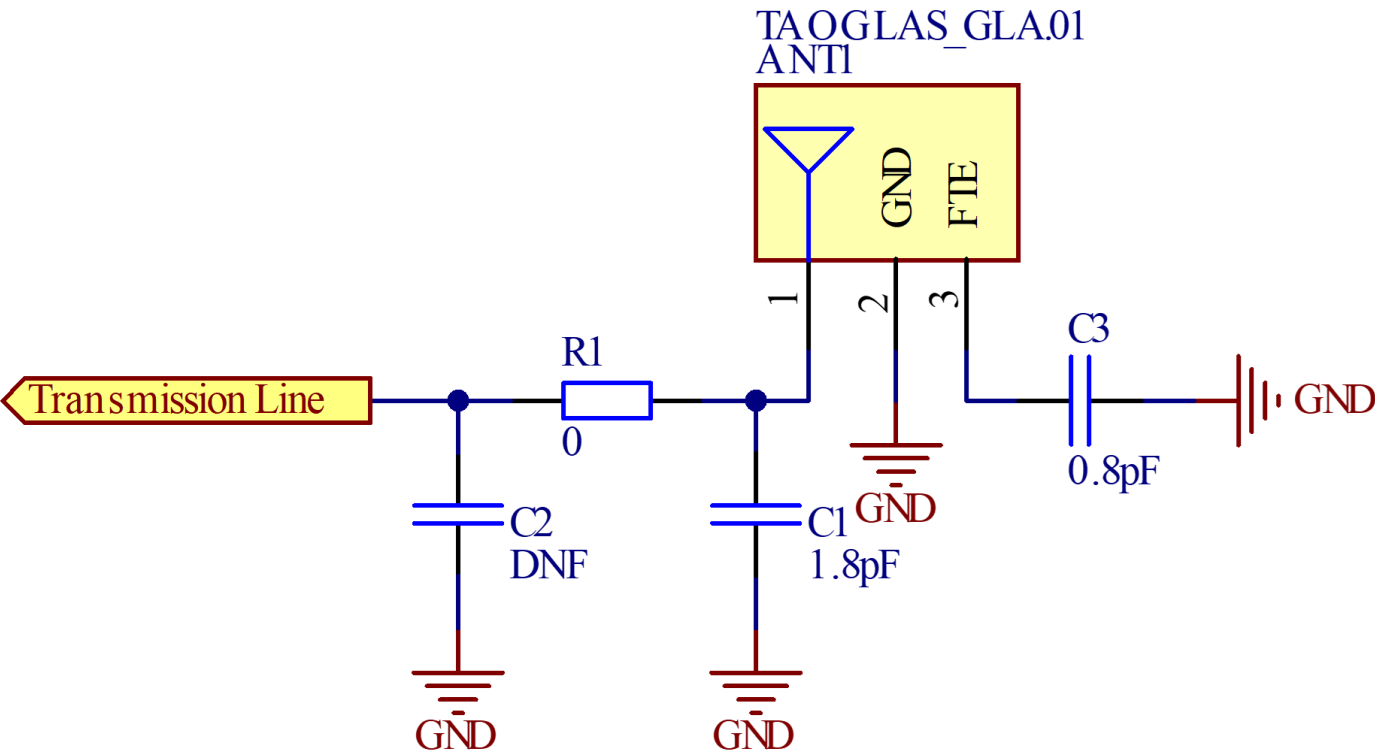

Designator	Type	Value	Manufacturer	Manufacturer Part Number
C1	Capacitor	1.8pF	Murata	GRM1555C1H1R8CA01D
C2	Not Fitted	-	-	-
C3	Capacitor	0.8pF	Murata	GCQ1555C1HR80CB01D
R1	Resistor	0 Ohm	YAGEO	RC0402JR-070RL

5.7 Antenna Integration

The GLA.01 should be placed mid-point on the long side of the PCB to take advantage of the ground plane extending from each side of the antenna.

The RF trace must maintain a 50 Ohm transmission line. A “Pi” Matching Network is recommended for the RF transmission line, the values and components for the matching circuit will depend on the tuning needed. Ground vias should be placed around the transmission line and the copper clearance area

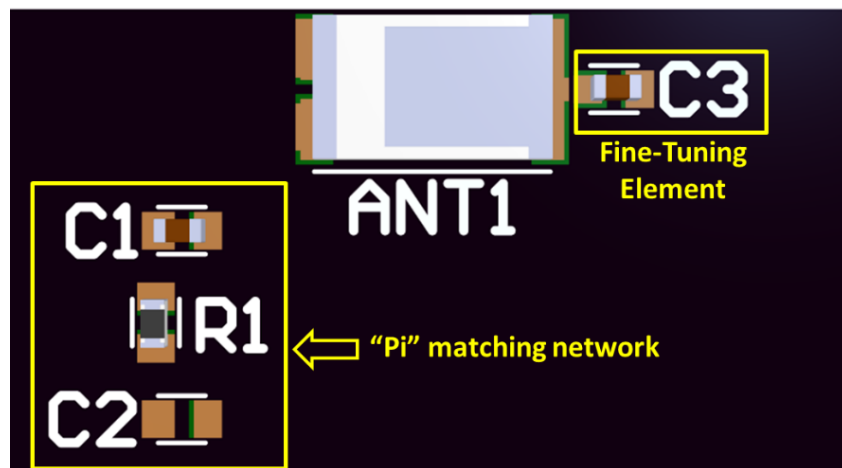

GLA.01 antenna mounted on a PCB, showing “Pi” matching network.

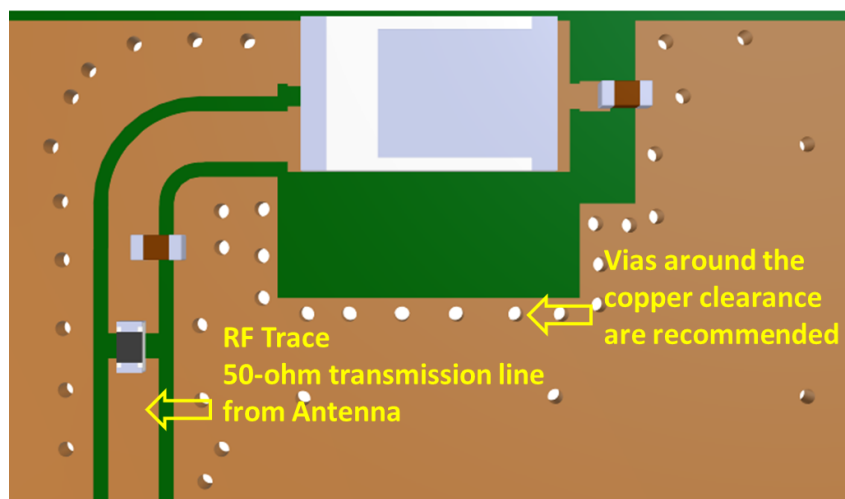

GLA.01 antenna mounted on a PCB, showing transmission line and integration notes.

5.8 Final Integration

The top side image shown below highlights the antenna transmission line. Taoglas recommends using a minimum of 80x40mm ground plane (PCB) to ensure optimal performance.

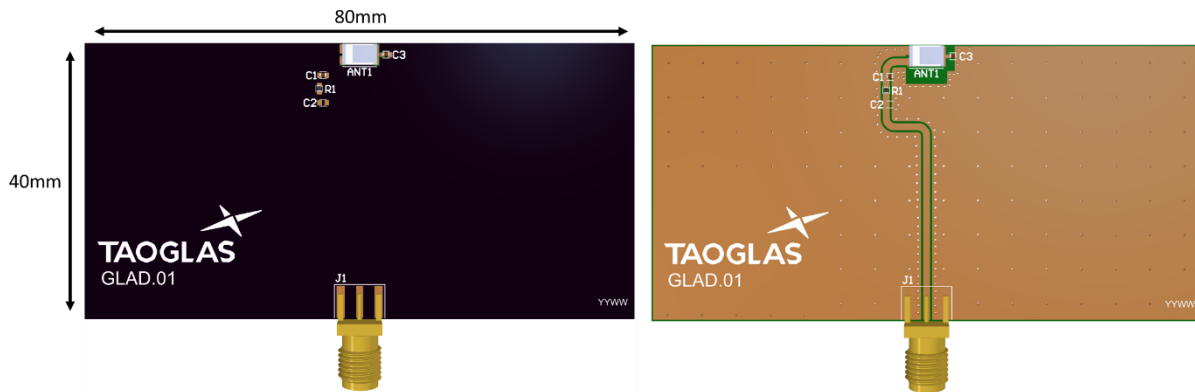

Top Side (GLA.01 placement on 80x40mm PCB reference design)

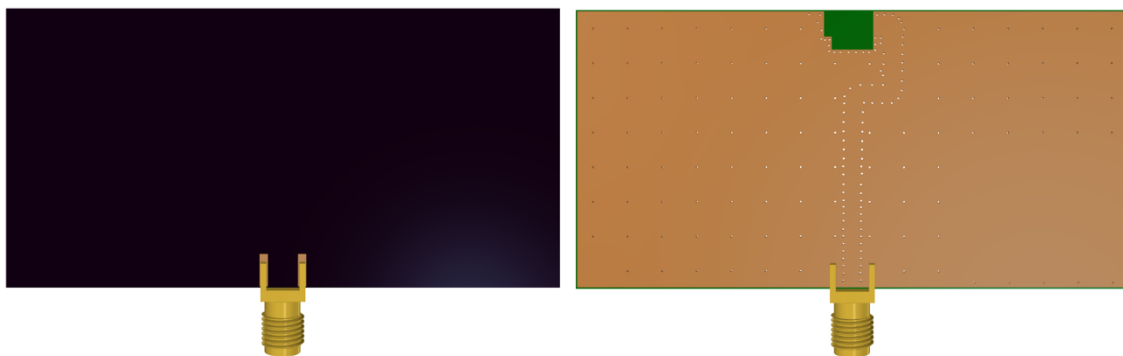

Bottom Side (80x40mm PCB)

6. Solder Reflow Profile

The GLA.01 can be assembled by following the recommended soldering temperatures are as follows:

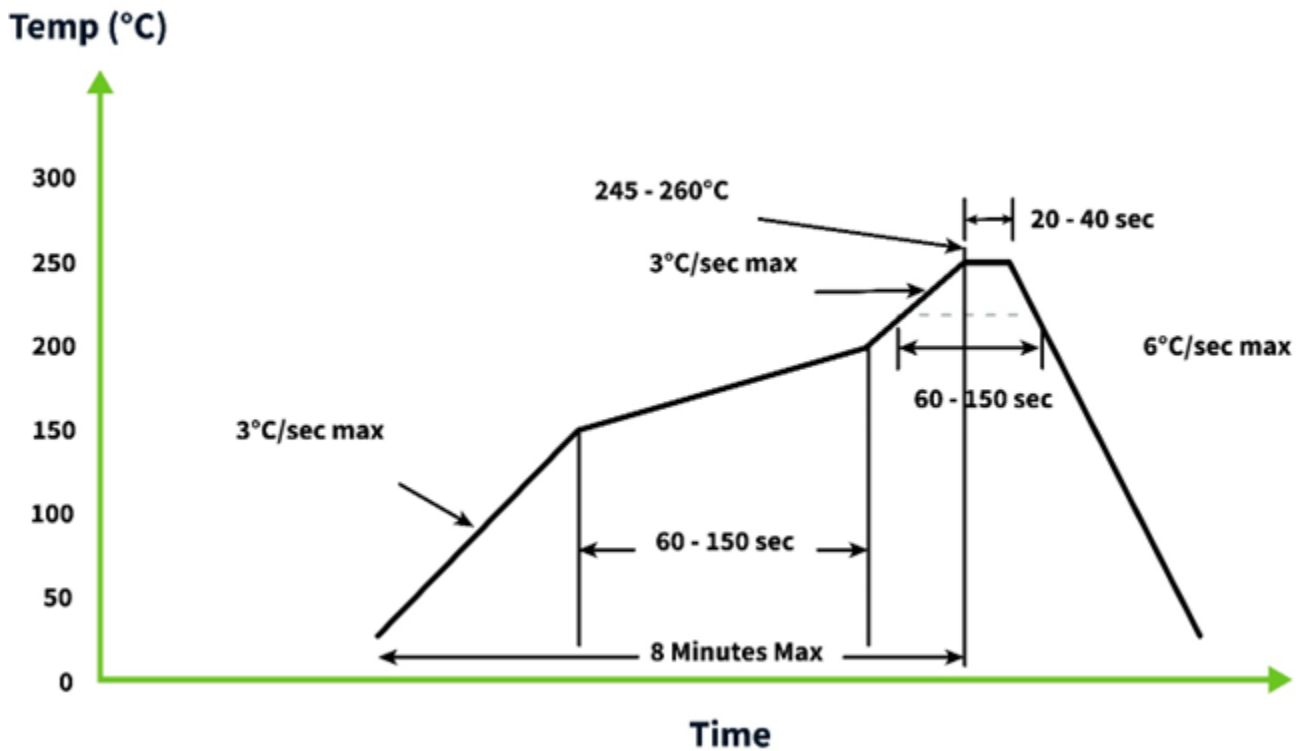

*Temperatures listed within a tolerance of +/- 10° C

Smaller components are typically mounted on the first pass, however, we do advise mounting the GLA.01 when placing larger components on the board during subsequent reflows.

Note: Soldering flux classified ROL0 under IPC J-STD-004 is recommended.

7. Antenna Characteristics

7.1 Test Setup

AUT



Vector Network Analyzer

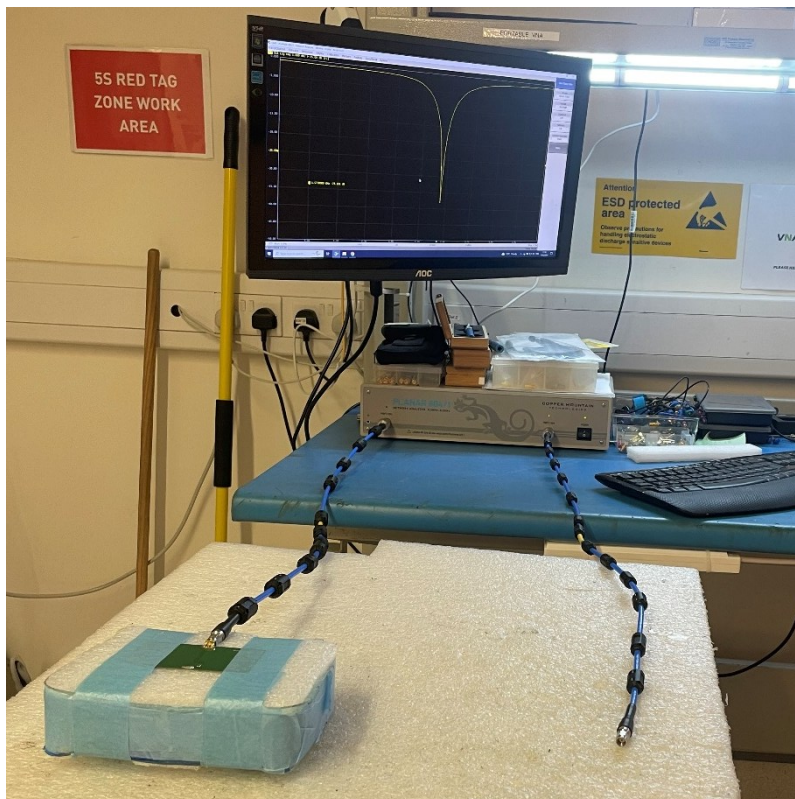

VNA Test Setup

7.2 Return Loss

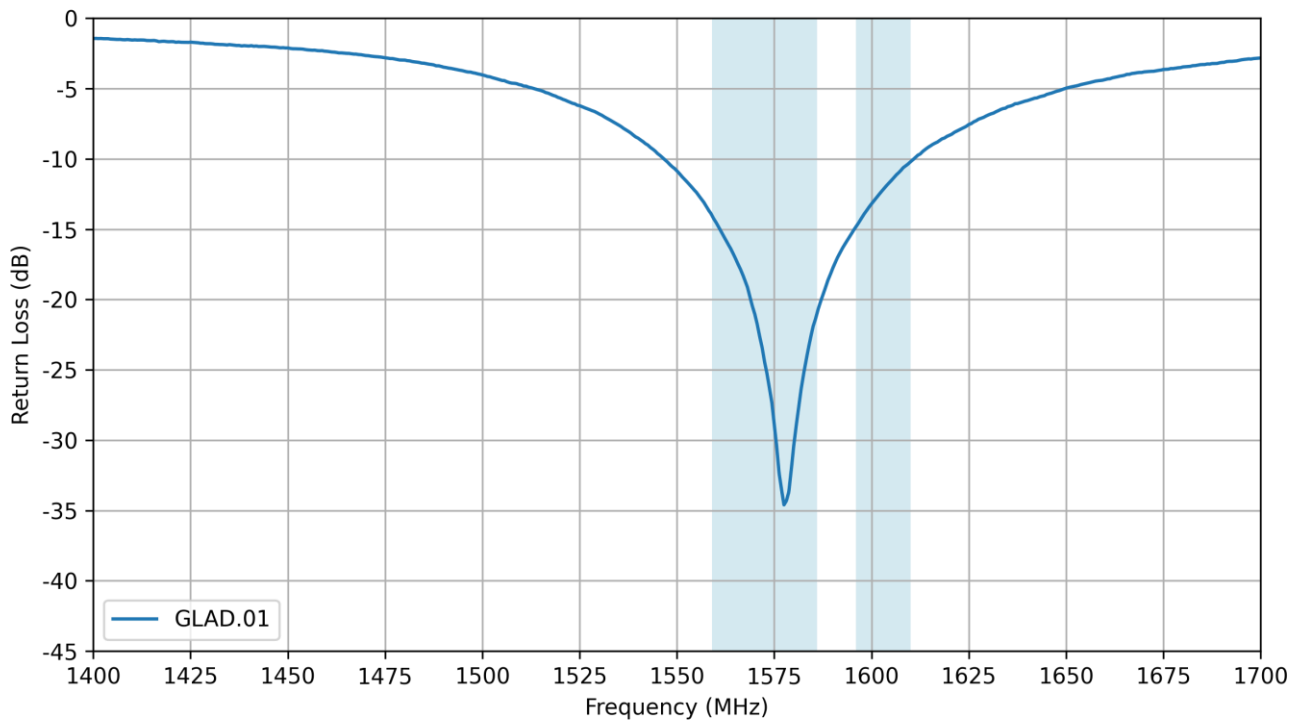

7.3 VSWR

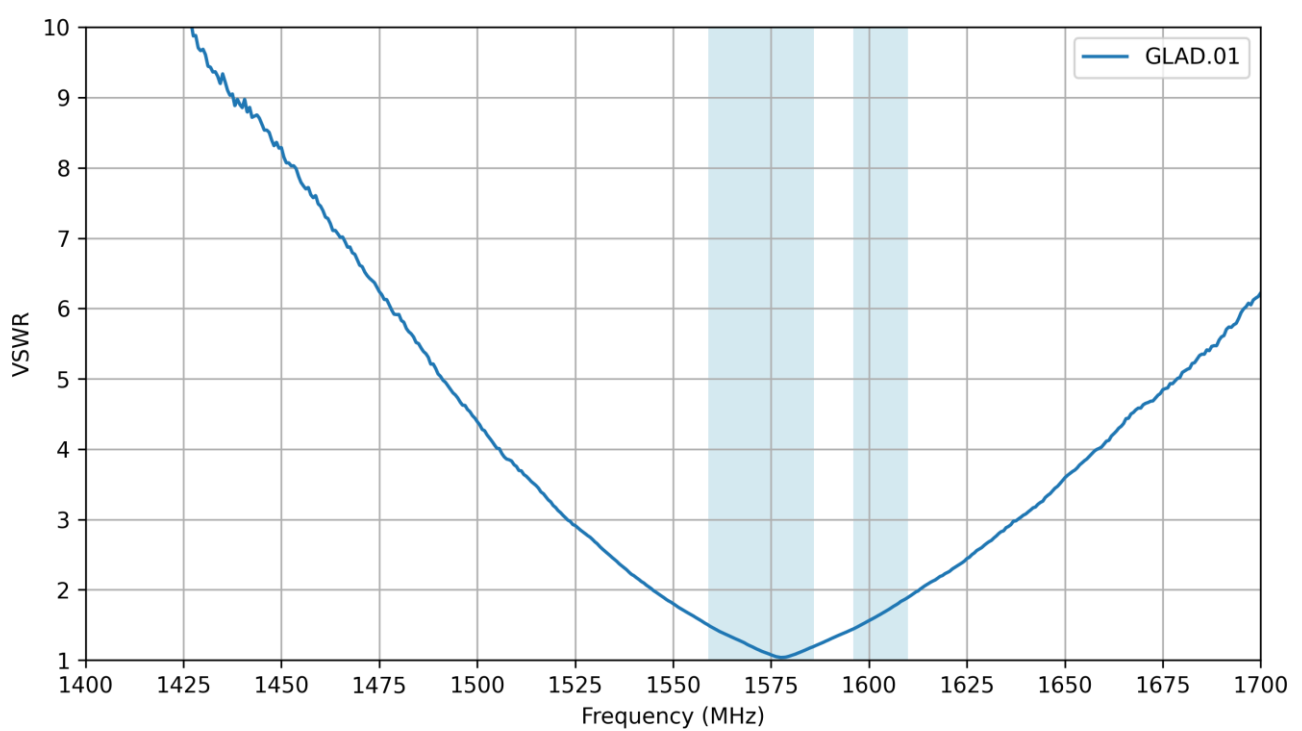

7.4 Efficiency

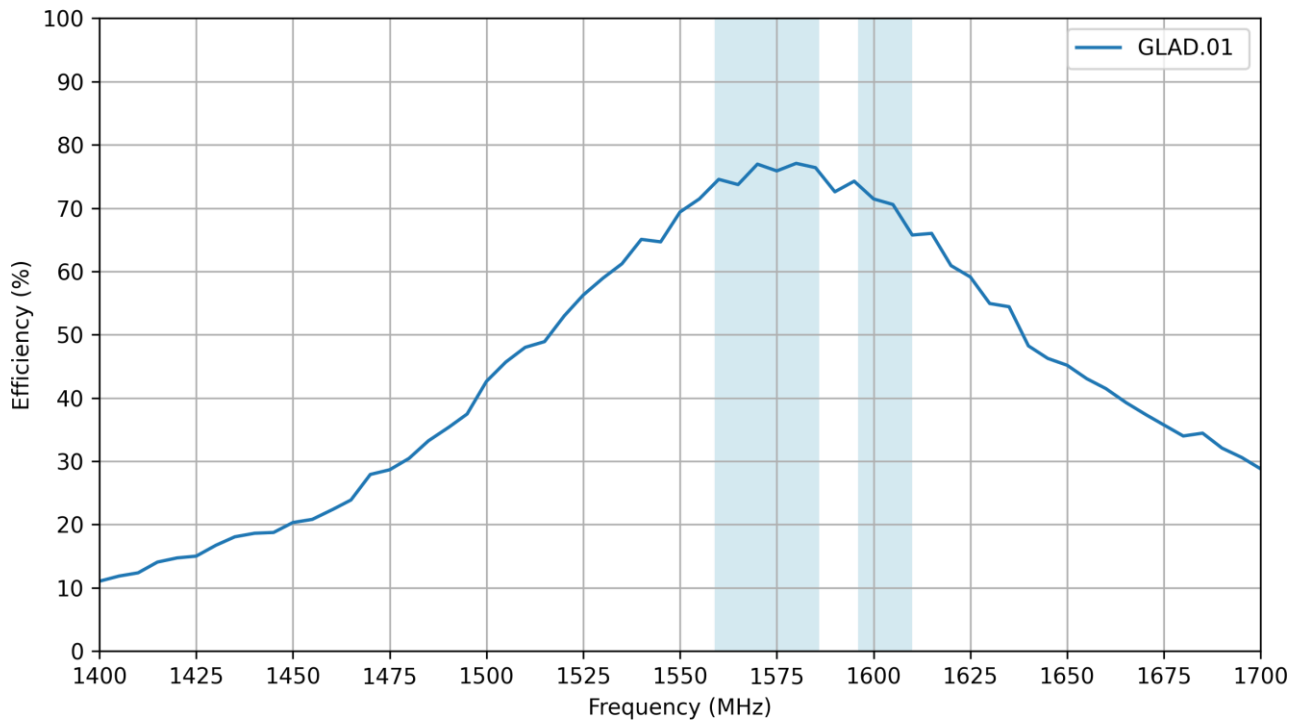

7.5 Average Gain

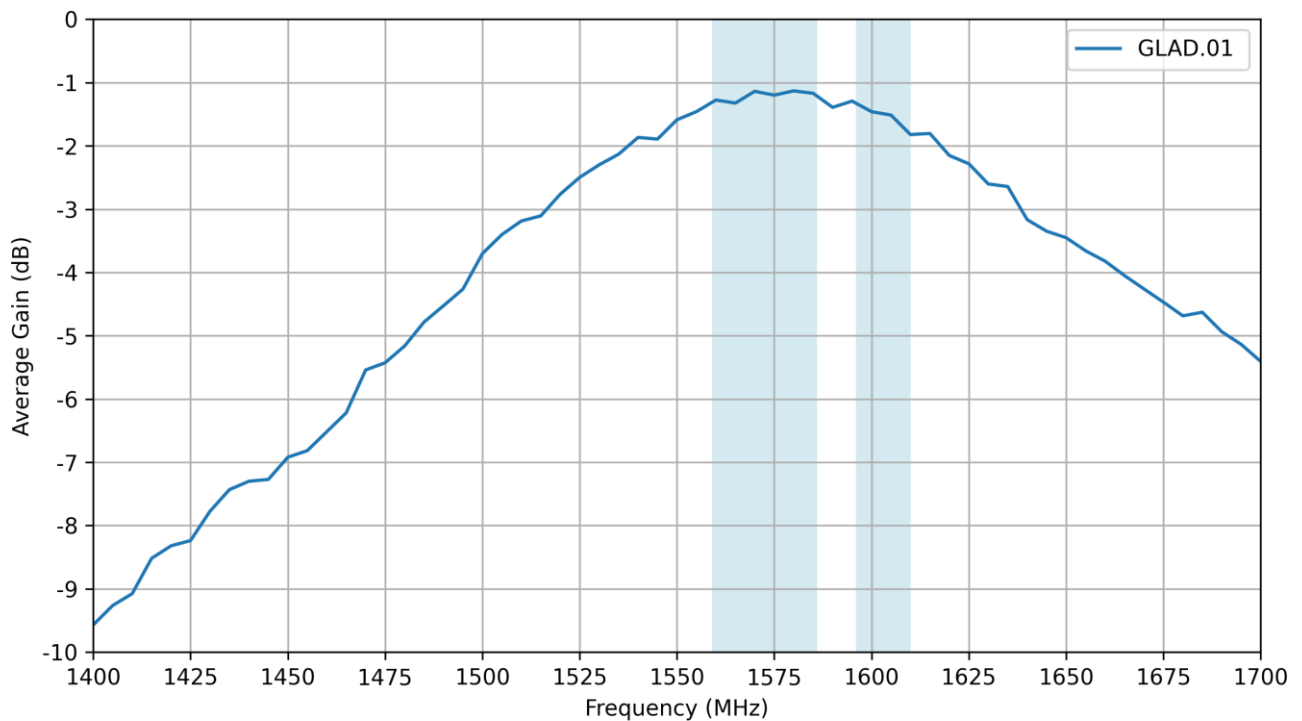

7.6 Peak Gain

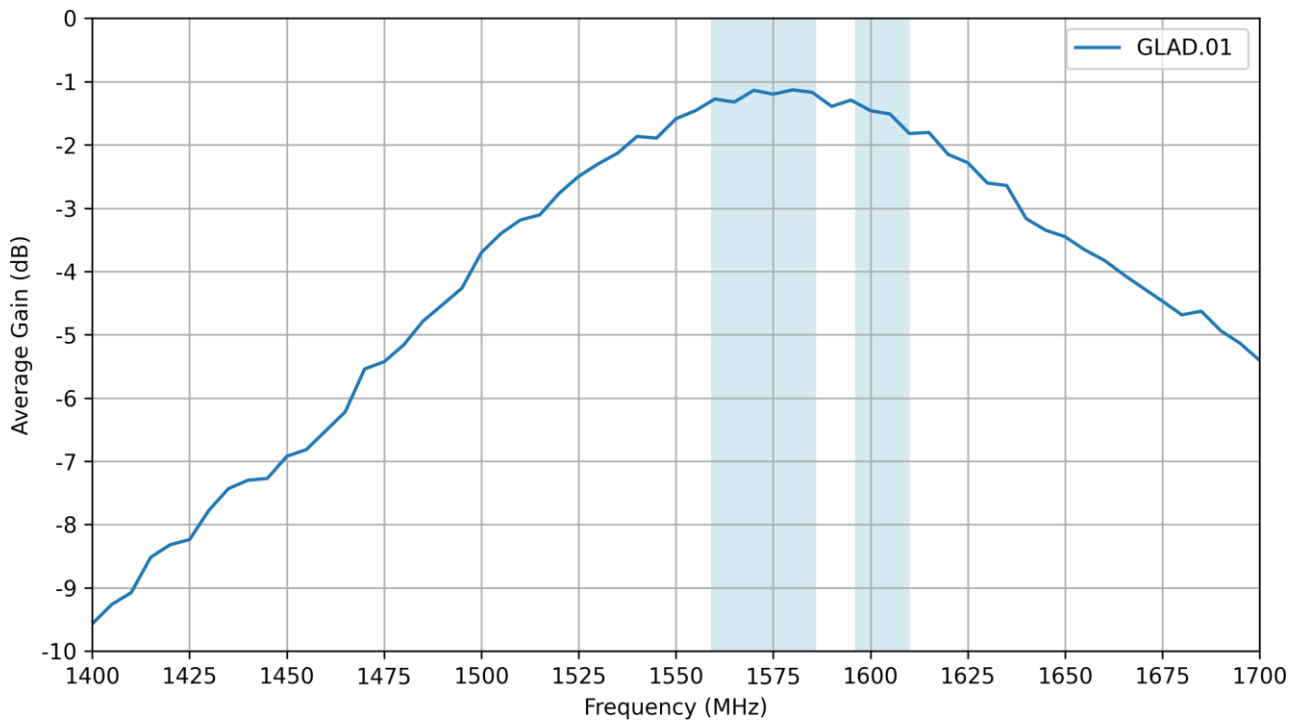

8. Radiation Patterns

8.1 Test Setup

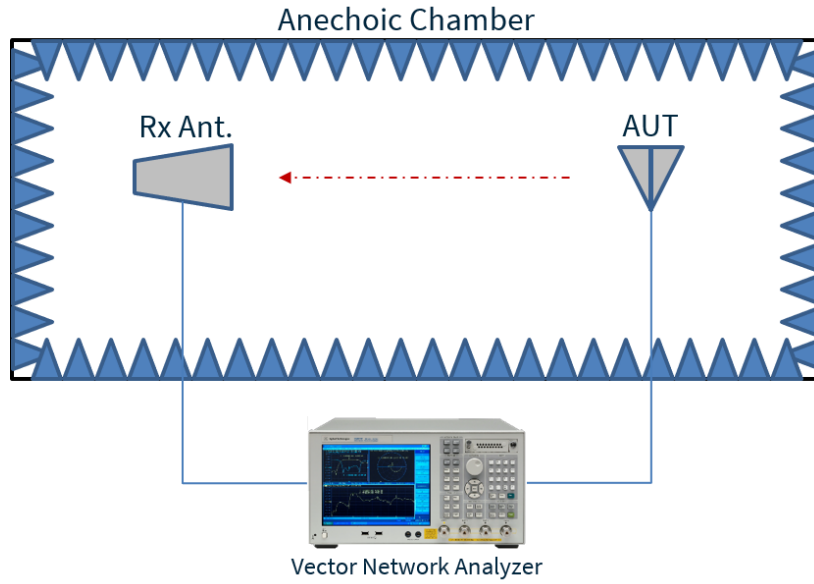

Chamber Test Setup

8.2 Patterns at 1575 MHz

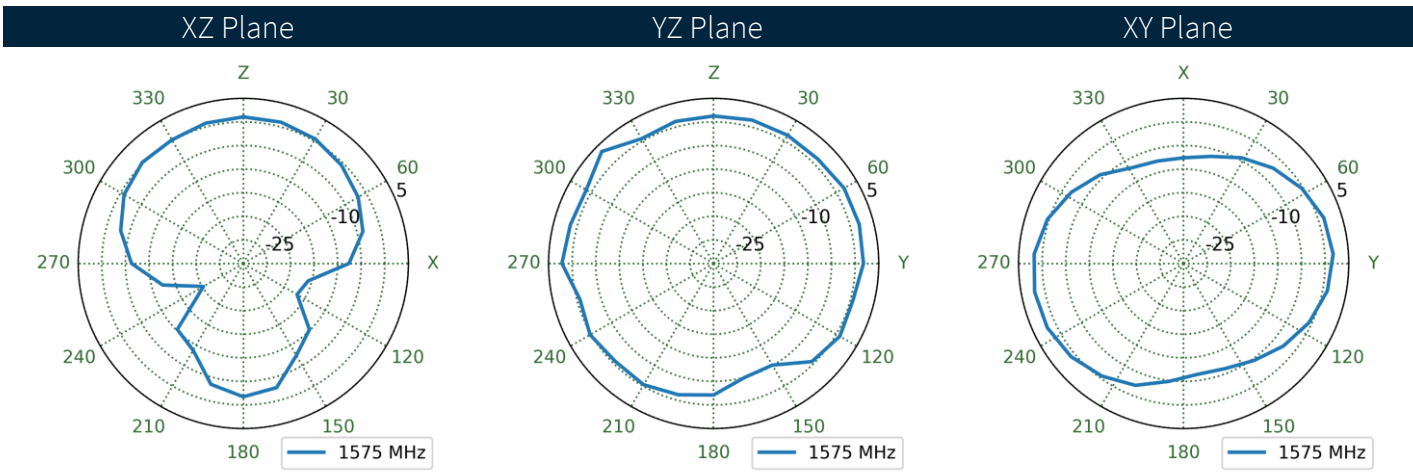
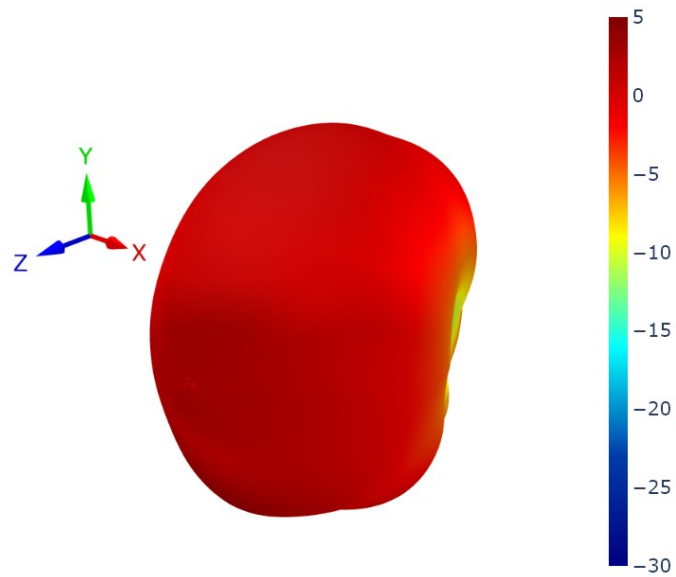

8.3 Patterns at 1560 MHz

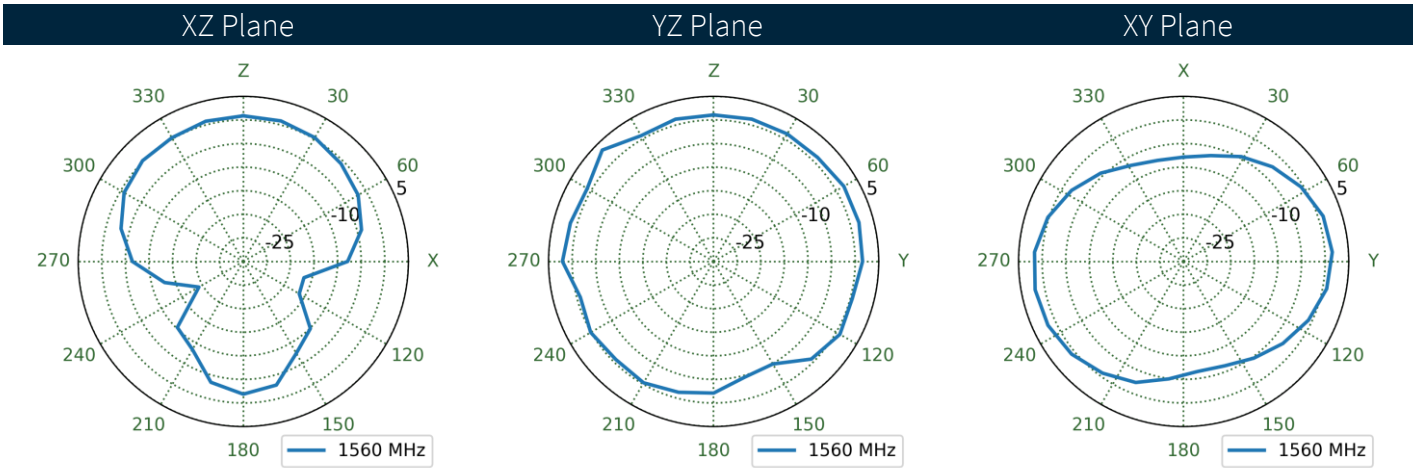
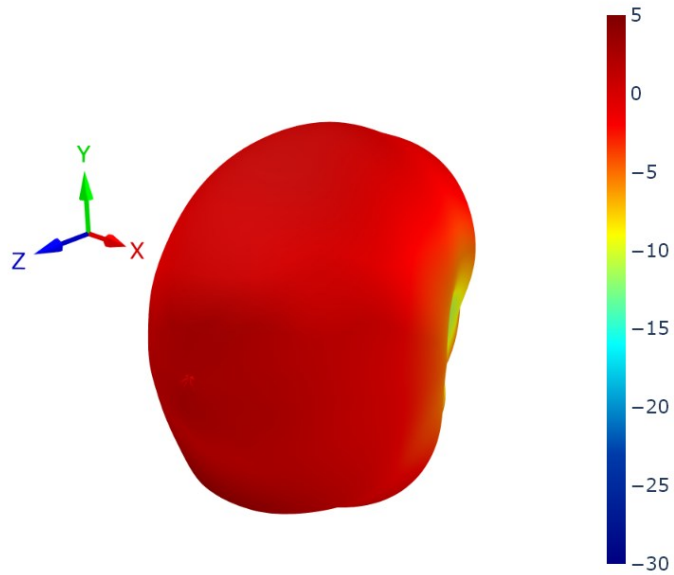

8.4 Patterns at 1605 MHz

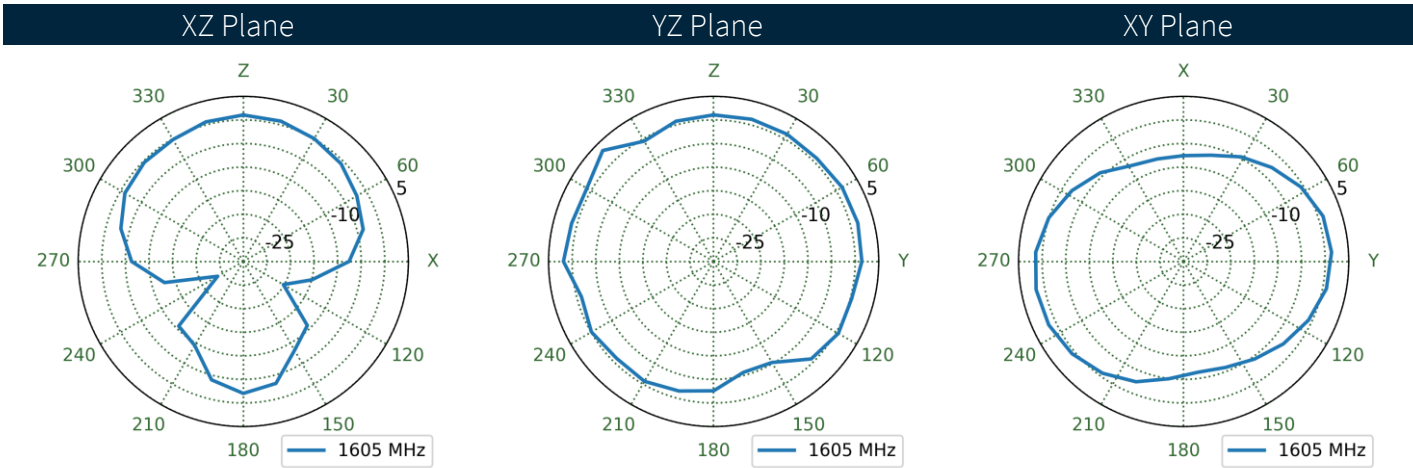
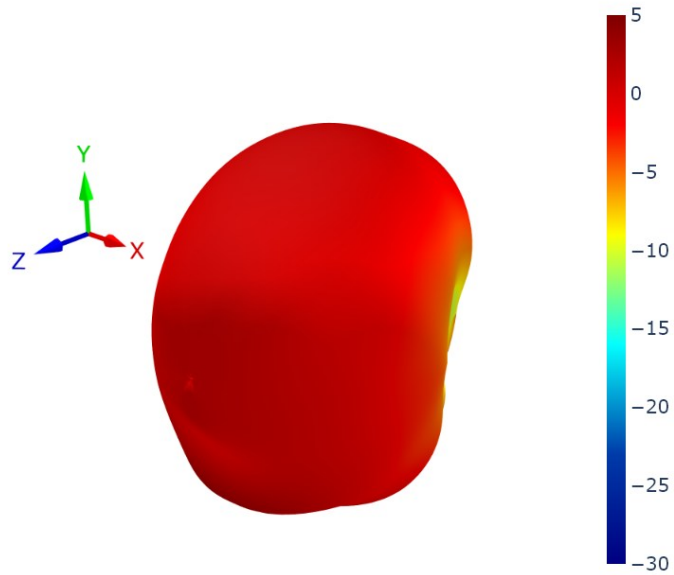

Changelog for the datasheet

SPE-11-8-040 – GLA.01

Revision: K (Current Version)

Date:	2025-03-27
Changes:	Full datasheet update.
Changes Made by:	Gary West

Previous Revisions

Revision: J

Date:	2023-05-09
Changes:	Updated Solder Reflow Information
Changes Made by:	Cesar Sousa

Revision: E

Date:	2021-07-25
Changes:	added Note on Page 14 under close up image
Changes Made by:	Aine Doyle

Revision: I

Date:	2023-02-28
Changes:	Antenna Integration Guide Added
Changes Made by:	Cesar Sousa

Revision: D

Date:	2013-07-18
Changes:	
Changes Made by:	STAFF

Revision: H

Date:	2021-11-1
Changes:	Format Change, MSL
Changes Made by:	Erik Landi

Revision: C

Date:	2021-04-25
Changes:	
Changes Made by:	STAFF

Revision: G

Date:	
Changes:	No info
Changes Made by:	STAFF

Revision: B

Date:	2011-07-18
Changes:	
Changes Made by:	STAFF

Revision: F

Date:	2014-04-14
Changes:	Updated by Wayne/Eddy
Changes Made by:	Aine Doyle

Revision: A (Original First Release)

Date:	2009-09-25
Notes:	Initial Release
Author:	STAFF



www.taoglas.com

