



TAOGLAS®



Datasheet

SXP.25.4.A.08

Part No:
SXP.25.4.A.08

Description:

2320 ~ 2345 MHz SDARS 25mm Patch Antenna (Satellite Digital Audio Radio System)

Features:

25*25*4mm Terrablast Patch Antenna

Excellent Efficiency: >75%

High Gain (Up to 9.2 dBiC at Zenith)

Excellent Impact Resistance

Ultra-Lightweight @ 5.6g

Optimized LHCP Radiation Pattern

Pin & Adhesive Mounting

Manufactured in an IATF16949 Approved Facility

RoHS & REACH Compliant

1. Introduction	3
2. Specifications	4
3. Antenna Characteristics	6
4. Radiation Patterns	9
5. Mechanical Drawing	11
6. Footprint	12
7. Soldering Recommendations	13
8. Packaging	14
<hr/>	
Changelog	15

Taoglas makes no warranties based on the accuracy or completeness of the contents of this document and reserves the right to make changes to specifications and product descriptions at any time without notice. Taoglas reserves all rights to this document and the information contained herein. Reproduction, use or disclosure to third parties without express permission is strictly prohibited.



1. Introduction



The Taoglas SXP.25.4.A.08 is part of a series of patch antennas designed for use with Satellite Digital Audio Radio Services (SDARS). It features left-hand circular polarization, low in-band axial ratio, and excellent gain characteristics in the 2320 to 2345 MHz band, making it compatible with the most popular satellite radio services available in many new vehicles.

SXP.25 comes in a convenient, compact form factor, with dimensions of 25mm x 25mm x 4mm. It is manufactured using Taoglas' patent pending Terrablast antenna technology, resulting in an ultra-lightweight patch that is 30% lighter than standard ceramic patches with ultra-impact resistant characteristics.

For further optimization to customer-specific device environments, custom tuned patch antennas can be supplied. Your regional Taoglas sales office can help you identify the best patch antenna for your specific SDARS application.

2. Specifications

Electrical	
Frequency	SIRIUS : 2326.25 MHz \pm 6.25 MHz XM : 2338.75 MHz \pm 6.25 MHz
Centre Frequency	2332.5 MHz \pm 12.5 MHz
Return Loss	SIRIUS: -10 dB max. XM: -10 dB max.
Zenith Gain	SIRIUS: +9 dBiC typ. XM: +9.2 dBiC typ.
Efficiency	SIRIUS: 78% XM: 77%
Axial Ratio	<3 @ Zenith
Polarization	LHCP
Impedance	50 Ω
Mechanical	
Dimensions	25 x 25 x 4mm
Pin Length	2.4mm
Pin Diameter	0.9mm
Weight	5.6g
Environmental	
Operation Temperature	-40°C to 85°C
Storage Temperature	-40°C to 85°C
Humidity	Non-condensing 65°C 95% RH
Reliability	
Low Temperature	-40°C, 24hrs
High Temperature	+85°C, 48hrs
Temperature Cycling	ISO16750 standard, total 240hrs
Temperature Step	ISO16750 standard, total 300mins
Drop Test	12m passed
Shock	10 shocks/ axis, 6 faces
Vibration	ISO16750 standard, 8 hours / axis
Pin pull force	>5kg-f

* Antenna properties were measured with the antenna mounted on 70*70mm Ground Plane

XM Gain Requirements (Satellite) – Ground Plane			
AUT Location	Elevation Angle(degrees)	XM Sirius Limits(dBic)	Measured Average Gain(dBic)
Passive Ground Plane	$20 \leq \phi \leq 25$	0.5	2.4
	$25 \leq \phi \leq 30$	1	3.4
	$30 \leq \phi \leq 50$	2	4.7
	$50 \leq \phi \leq 70$	4	6.9
	$70 \leq \phi \leq 90$	2	8.1

XM Gain Requirements (Terrestrial) – Ground Plane			
AUT Location	Elevation Angle(degrees)	Antenna Mean Passive VP Gain Over Solid Angle (dBi)	Antenna P/P Gain variation (dB)
Passive Ground Plane	$0^\circ \leq \phi \leq 10^\circ$	-3.1dBi	-
	$\Phi = 5^\circ$	-	2326.25MHz=1.6 dBic 2338.75MHz=1.3 dBic

3. Antenna Characteristics

3.1 Return Loss

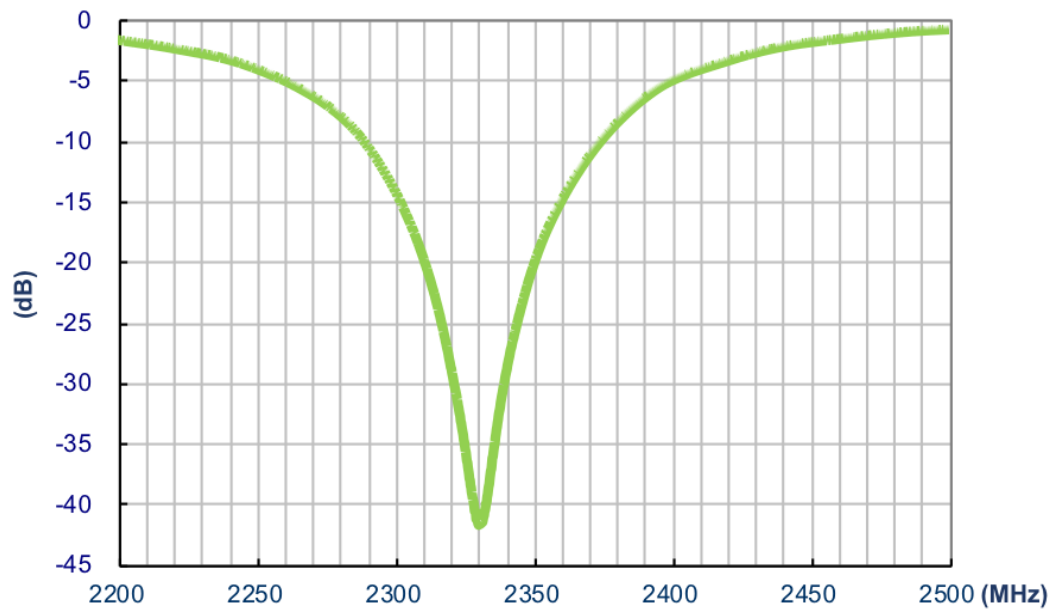

3.2 Efficiency

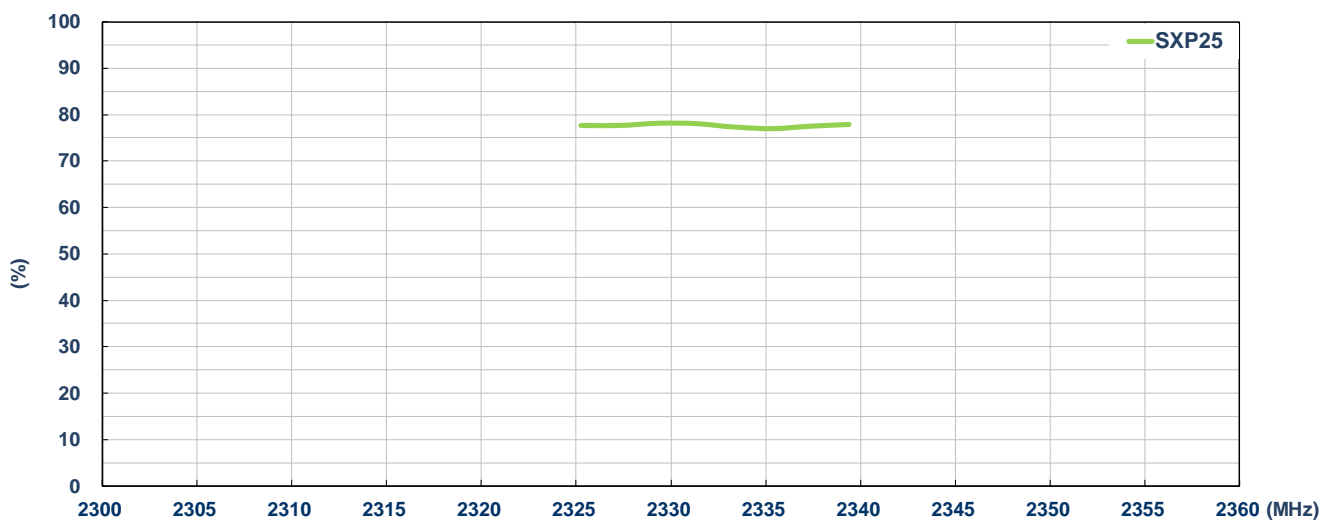

3.3 Average Gain

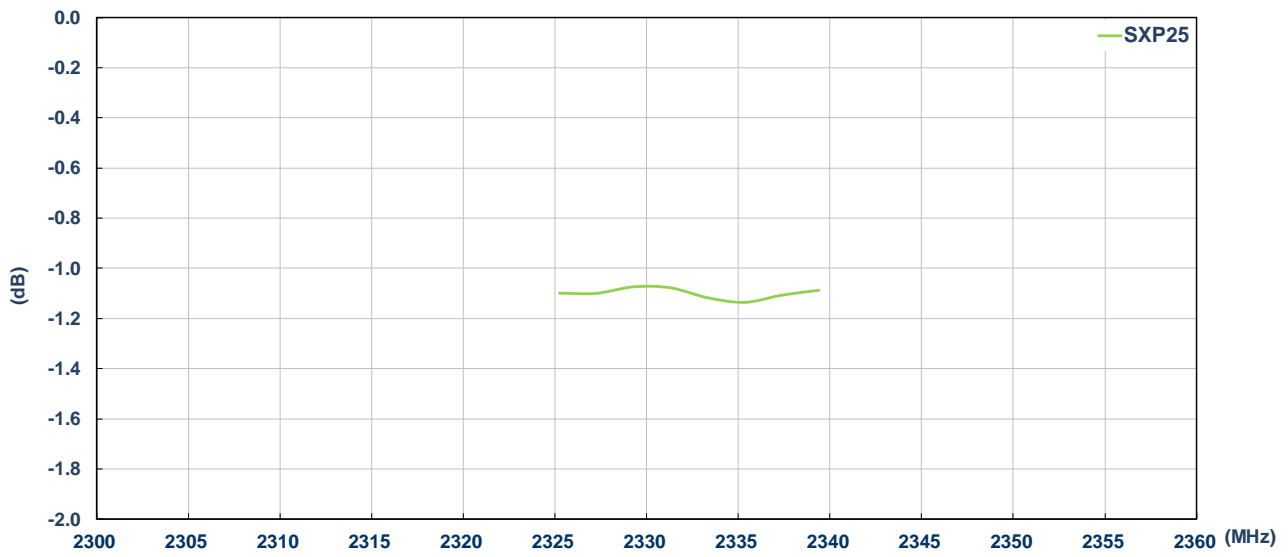

3.4 Peak Gain

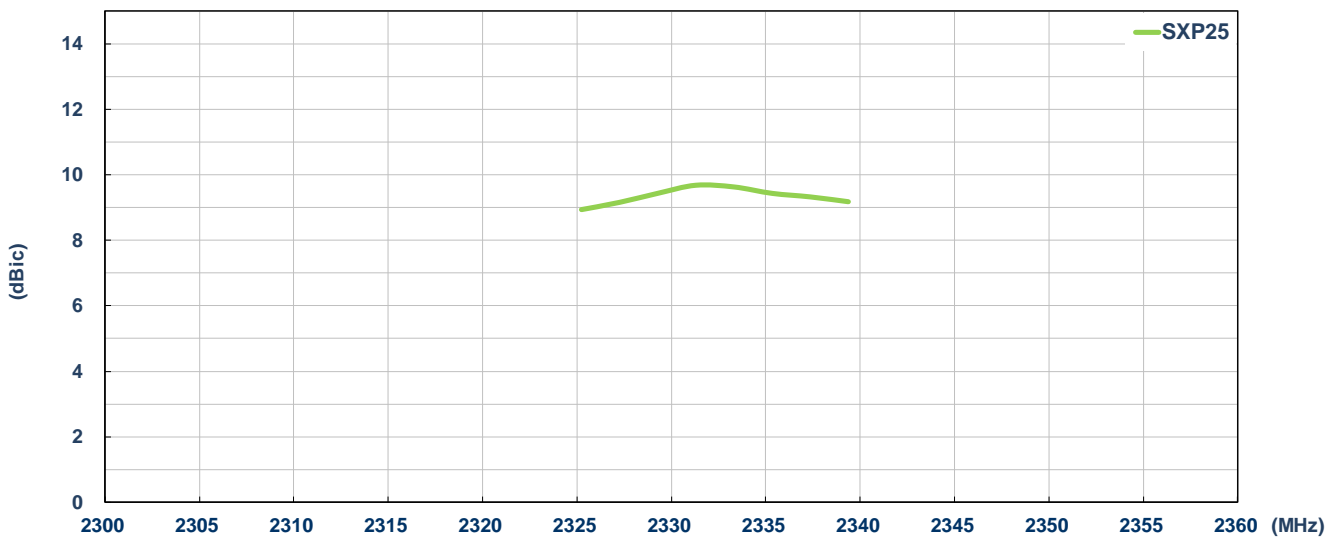

3.5 Axial Ratio @ Phi=0°

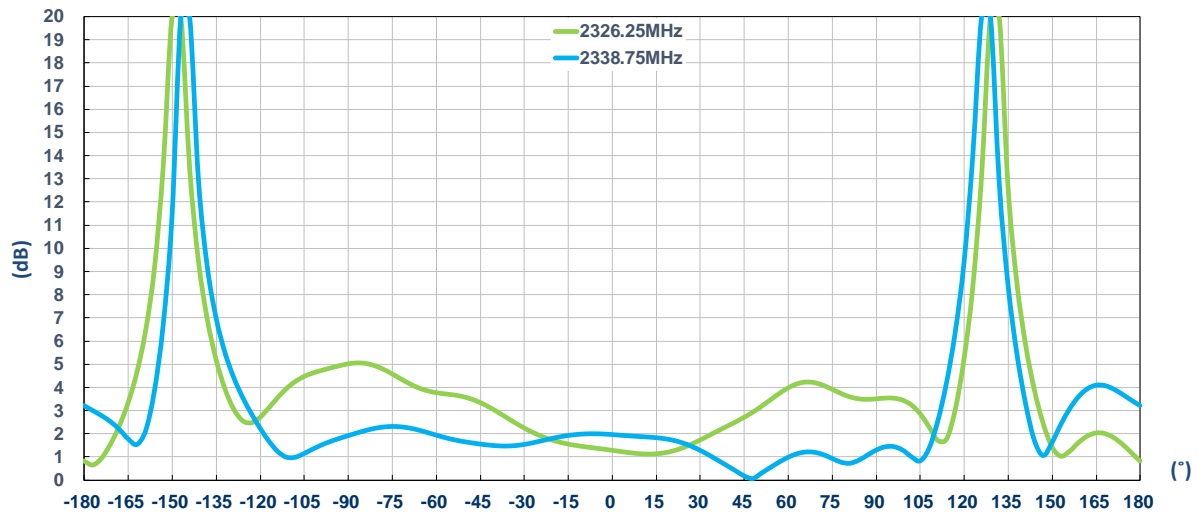

3.6 Axial Ratio @ Phi=90°

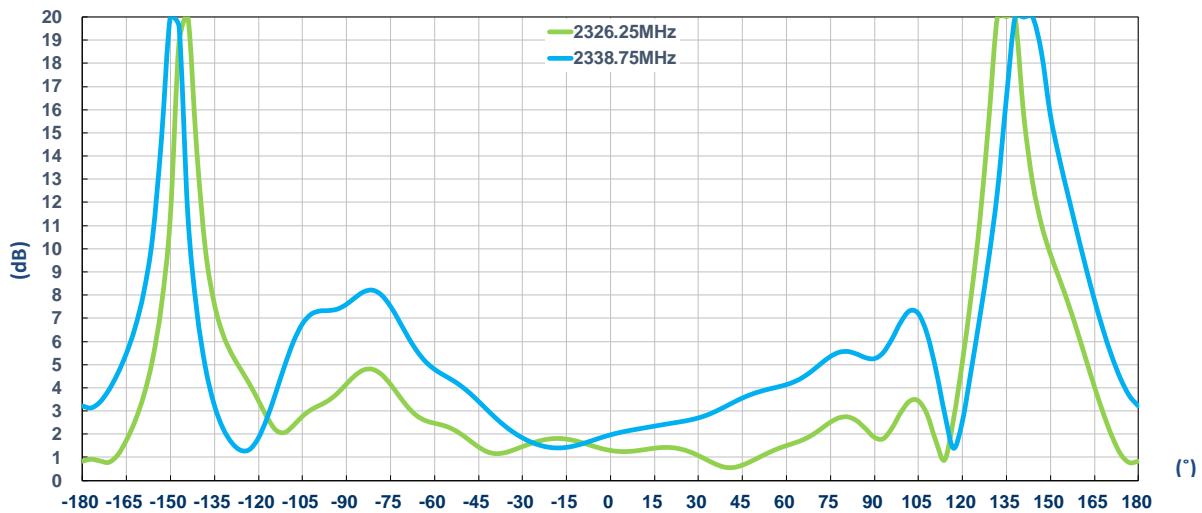

4. Radiation Patterns

4.1 Test Setup

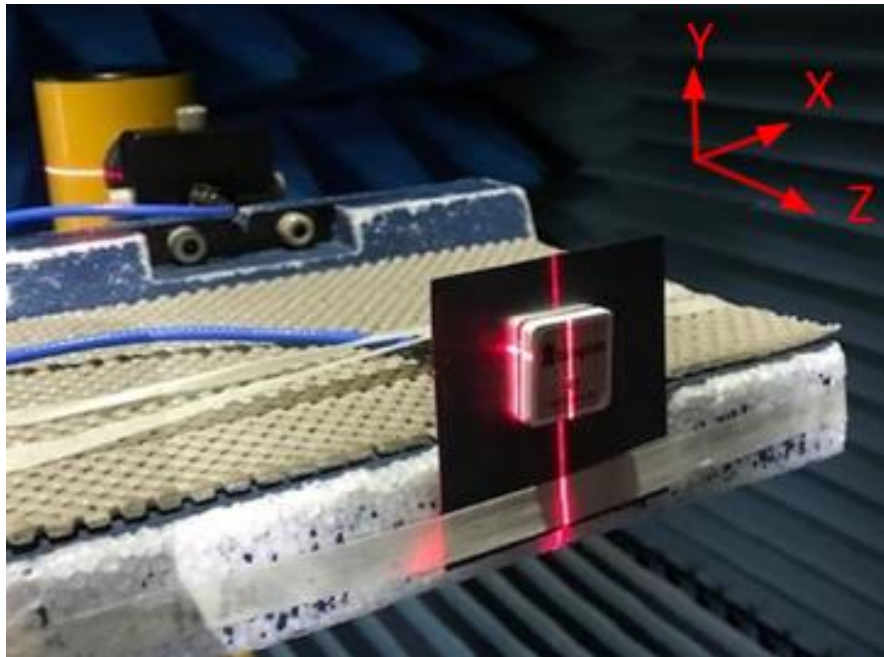

4.2 3D and 2D Radiation Patterns

2326.25MHz

2338.75MHz

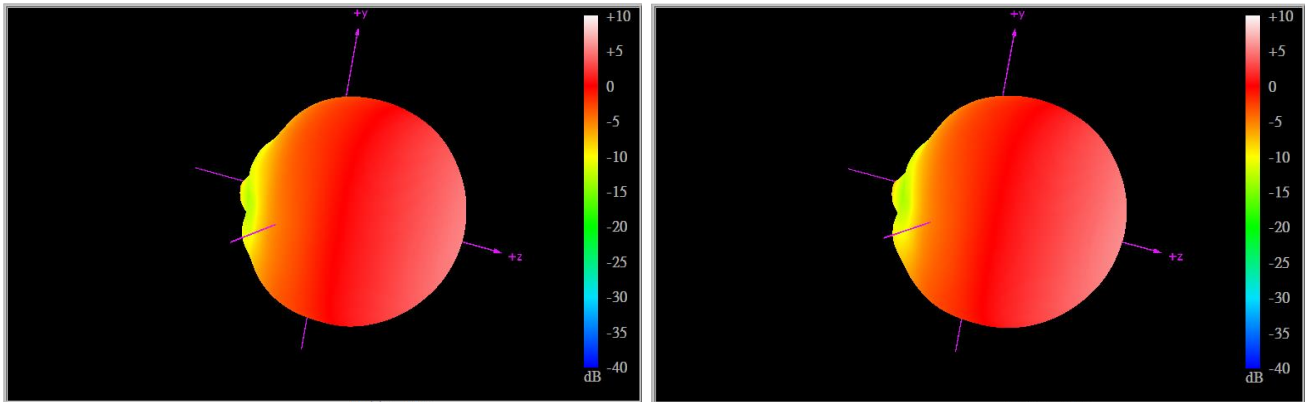

XY Plane

XZ Plane

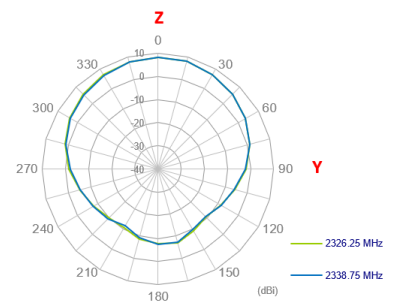
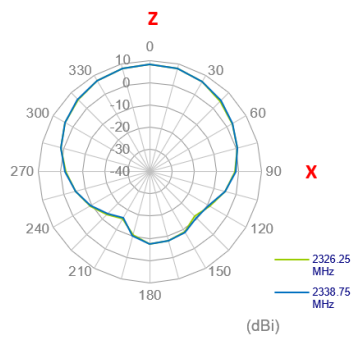
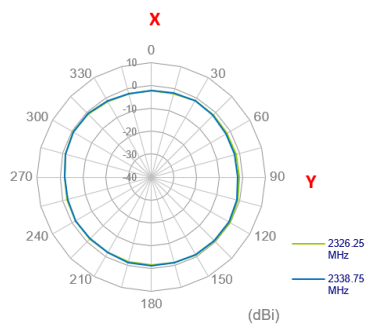

YZ Plane

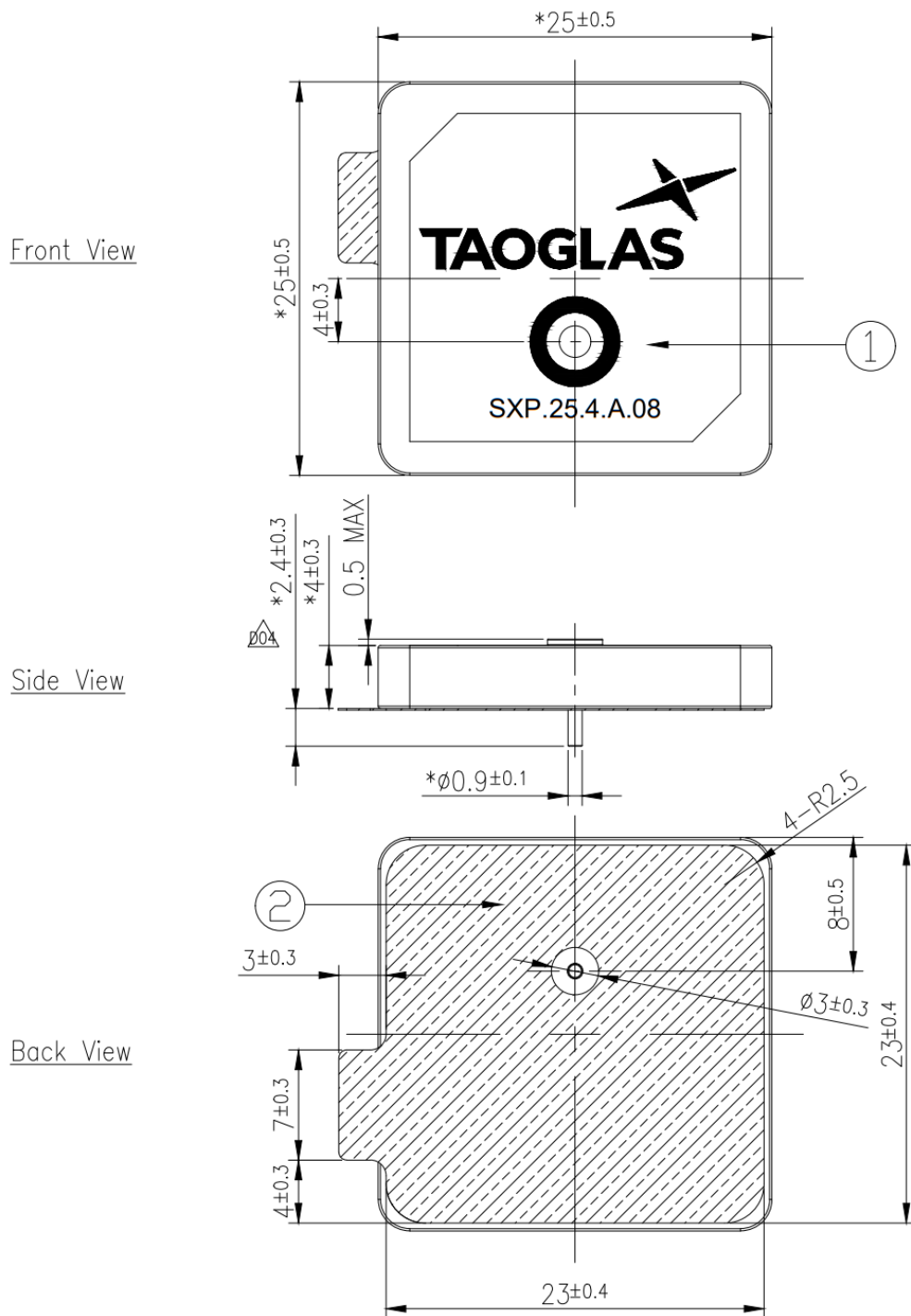

5. Mechanical Drawing (Units: mm)



NOTES:

1. Double sided adhesive area. 
2. Soldermask area 
3. "*" Critical Dimensions.

	Name	P/N	Material	Finish	QTY
1	SXP.25 Patch	013D136000J012	Terrablast	Clear	1
2	Double Sided Adhesive	013D136000J012	NITTO 5015	White Liner	1

6. Footprint

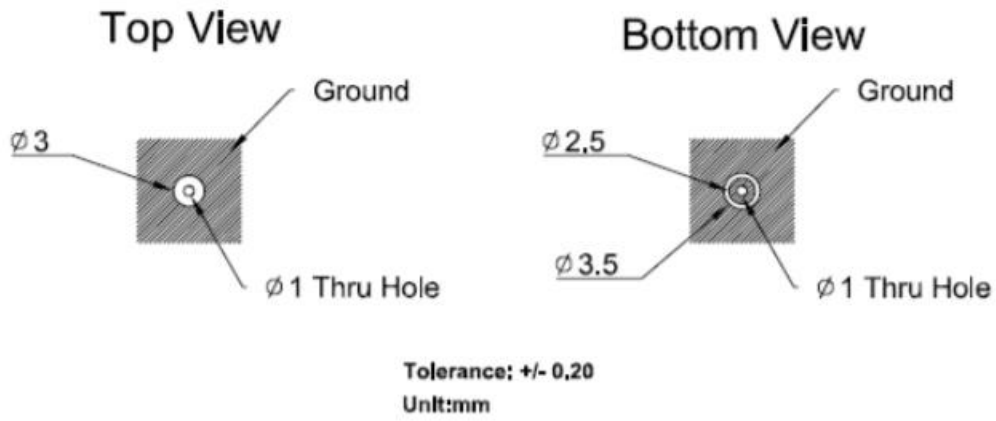

7. Soldering Recommendations

7.1 Automated Ferrochrome Soldering Machine

Soldering Temperature: 360-380°C
 Soldering Duration: 3~4 seconds

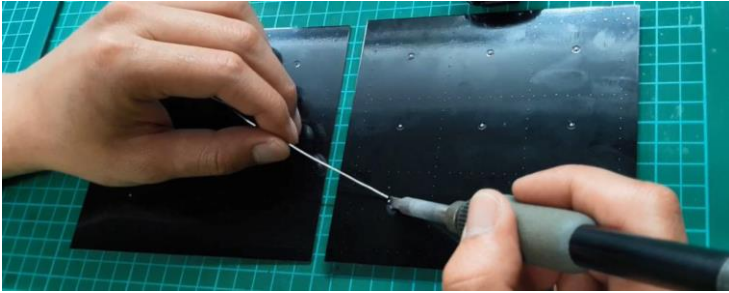

7.2 Automated Ferrochrome Soldering Machine

Soldering Temperature: 360-380°C
 Soldering Duration: 3~4 seconds

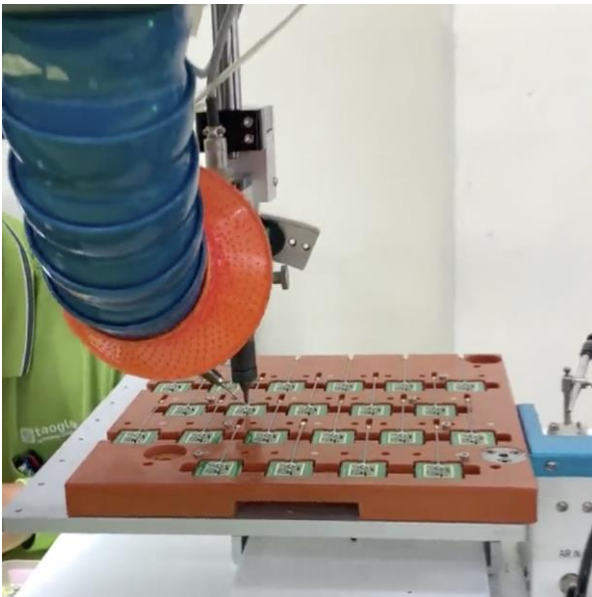

Please note that this process will require a one-time fixture to be made for each PCB design.

8. Packaging

50 pcs SXP.25.4.A.08 per tray
 Tray Dimensions - 261*295mm
 Total Weight - 12g

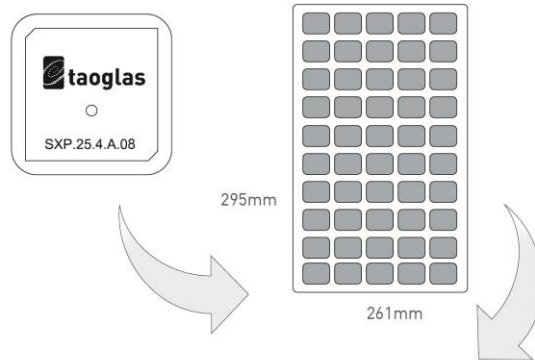

4 trays / 200 pcs SXP.25.4.A.08 per small box
 Small box dimensions - 261*152*118mm
 Weight - 2.4Kg

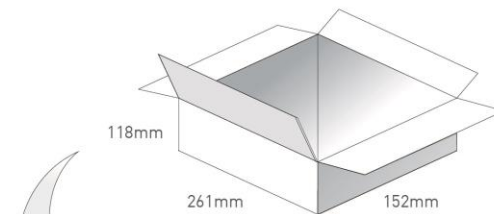

4 small boxes / 800 pcs SXP.25.4.A.08 per carton
 Carton dimensions - 330*280*270mm
 Weight - 9.5Kg

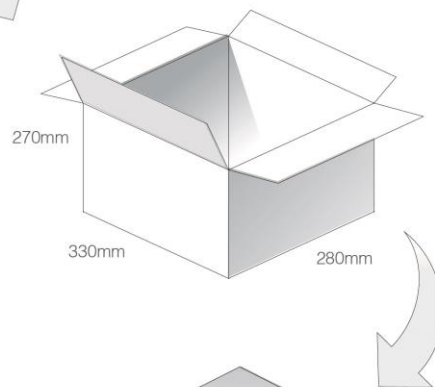

Pallet Dimensions 1200mm*1000mm*1280mm
 48 Cartons per pallet
 12 Cartons per layer
 4 Layers

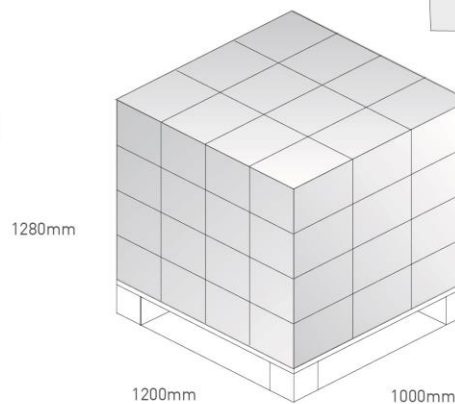

Changelog for the datasheet

SPE-18-8-081- SXP.25.4.A.08

Revision: D (Current Version)

Date:	2023-04-11
Changes:	Updated Drawing
Changes Made by:	Cesar Sousa

Previous Revisions

Revision: C

Date:	2021-06-21
Changes:	Updated Pin Length to 2.4mm Updated Drawing
Changes Made by:	Gary West

Revision: B

Date:	2020-09-12
Changes:	Amended soldering recommendations and updated to new datasheet format.
Changes Made by:	Gary West

Revision: A (Original First Release)

Date:	2018-23-08
Changes:	
Changes Made by:	TH



TAOGLAS®

