



TAOGLAS®



Datasheet

RJ45 ICM 1G Base-T Short Body

Part No:
TMJG4813-8KGDNL4

Description:

RJ45 connector with integrated magnetics 1G Base-T
Single Port Tab-DOWN with right angle THT mount and LED

Features:

Short Body
Shielded EMI Finger
Transformer + CMC
Industrial grade

1. Introduction	3
2. Specifications	4
3. Mechanical	5
4. Electrical	6
5. Packaging	7
<hr/>	
Changelog	8

Taoglas makes no warranties based on the accuracy or completeness of the contents of this document and reserves the right to make changes to specifications and product descriptions at any time without notice. Taoglas reserves all rights to this document and the information contained herein. Reproduction, use or disclosure to third parties without express permission is strictly prohibited.



1. Introduction



The Taoglas TMJG4813-8KGDNL4 is a single-port, tab-down RJ45 Integrated Connector with a shielded EMI Finger and short body design. It features a widely recognized footprint and a compatible package that aligns with industry standards for RJ45 Integrated Connectors, making it popular among users. This connector supports 1G Base-T connection.

Typical Applications Include:

- Industrial Automation
- Hubs
- Routers
- Switches
- Wireless Access Points

Taoglas Magnetics offer an extensive product line of RJ45 Integrated Connectors designed for commercial and industrial grade applications, supporting 10/100 Base-T (Atmos100 Series) and 1G Base-T (Atmos1000 series). These surface mount or through-hole components provide reliable performance and maintain signal integrity that meets IEEE 802.3 standards, and they are UL certified. The Power over Ethernet options are also available including PoE, PoE+ and PoE++.

The majority of Taoglas RJ45 ICMs are manufactured with fully automated winding, assembly & testing to ensure consistent performance, quality and reliability while ensuring cost competitiveness for its customers. These products are fully compliant with the REACH and RoHS directive, and compatible with all major PHY vendors.

For customized products or support with integration, contact your regional Taoglas customer support team for further information.

2. Specifications

Electrical Performance @25°C	
Inductance	350µH Min @ 100KHz, 0.1V, 8mA DC BIAS
Turns Ratio (±2%)	1CT:1CT
Insertion Loss	-1.0dB MAX @ 10-100MHz
Return Loss	-20dB MIN @ 1-10MHz
	-16dB MIN @ 10-30MHz
	-12dB MIN @ 30-60MHz
	-10dB MIN @ 60-100MHz
Crosstalk	-40dB MIN @ 1-30MHz
	-35dB MIN @ 30-60MHz
	-30dB MIN @ 60-100MHz
Common Mode Rejection	-30dB MIN @ 1-50MHz
	-20dB MIN @ 50-100MHz
Hi-Pot	1500Vrms Min

Environmental Specifications	
Operating Temperature	-40°C TO +85°C

Material Specifications	
Housing	Thermoplastic PBT+30%G. F UL94V-0
Shield	SUS 304 1/2EH Thickness=0.2mm
Contact Material	Phosphor Bonze C5210R-EH Thickness=0.35mm
Contact plating	Gold 30 micro-inches min. in contact area
Pins	Brass C2680R-H Thickness=0.35mm
Wave solder tip temperature	250°C, 5 Sec

Compliance	
	IEEE 802.3
	RoHS Compliant

Storage requirements	
Humidity	MSL - 1
Storage Temperature	-40°C TO +85°C

3. Mechanical

3.1 Mechanical Drawings

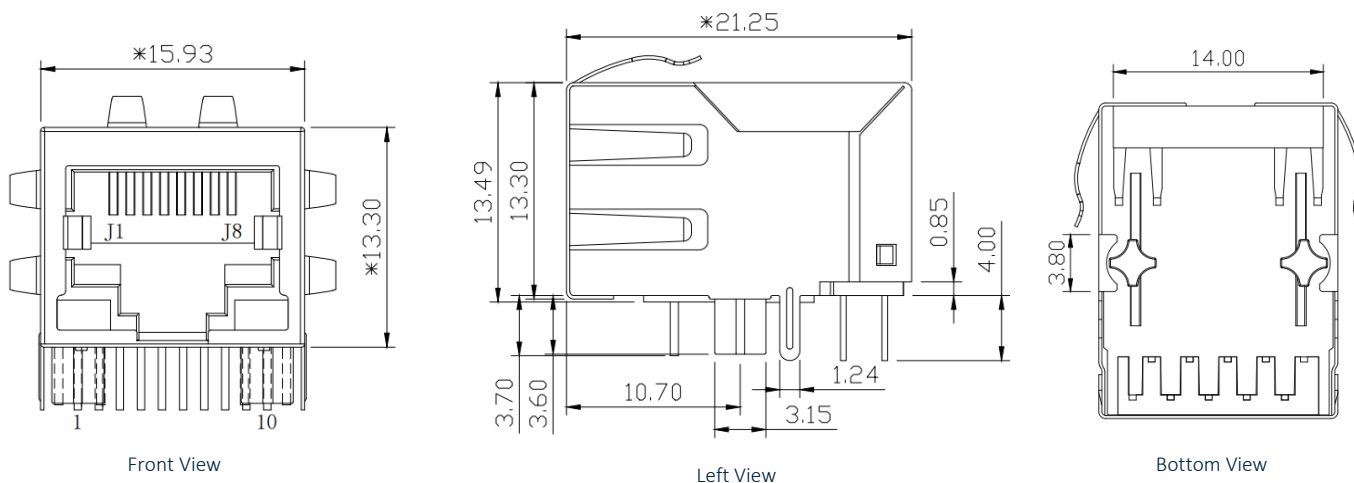

Mechanical Specifications	
Height	13.30 mm
Width	15.93 mm
Depth	21.25 mm
Weight	6 g
Mounting Style	Through Hole (THT)
Mounting Angle	Right Angle

Dimensions are in millimeters with the following tolerances: X.XX = ± 0.25

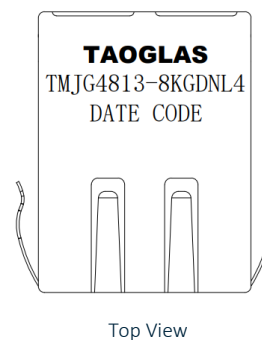

Top View

3.2 PCB Layout

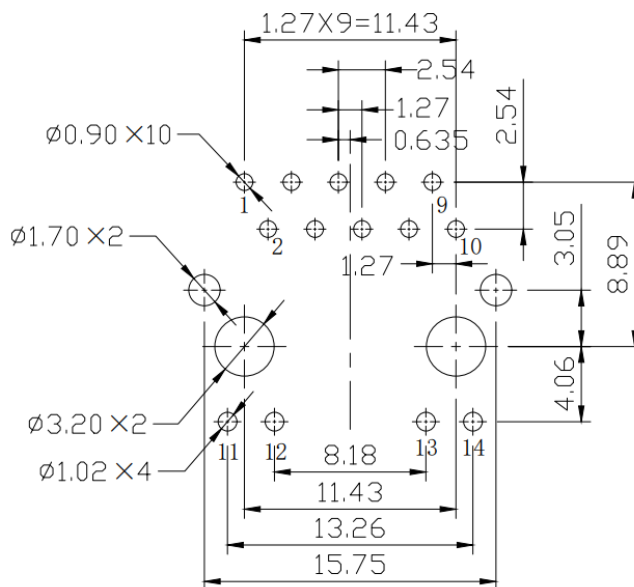

Suggested PCB Layout (Top View)

Dimensions are in millimeters with the following tolerances: X.XX = ± 0.10

4. Electrical

4.1 Electrical Drawings

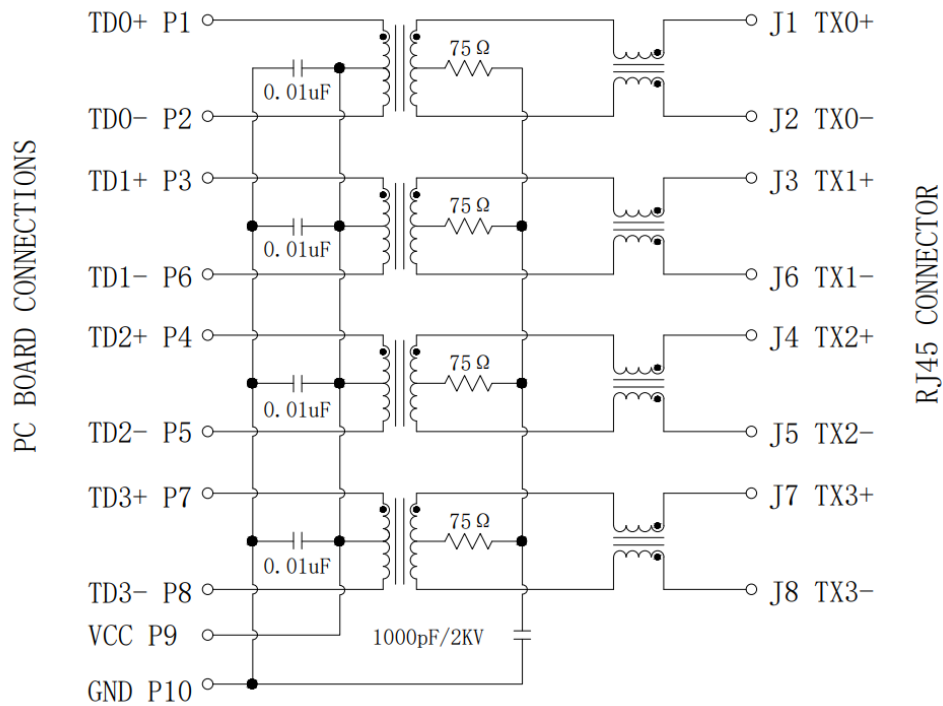

4.2 LED

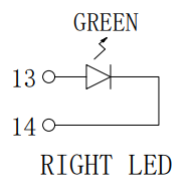
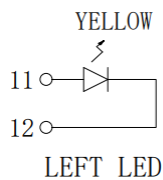

Emitting Color	λ_p (nm)	$V_F@I_F=20mA$	$I_R @V_R=5V$
GREEN	565	1.8~2.6V	10 μA max
YELLOW	585	1.8~2.6V	10 μA max

4.3 Profile of Wave Solder

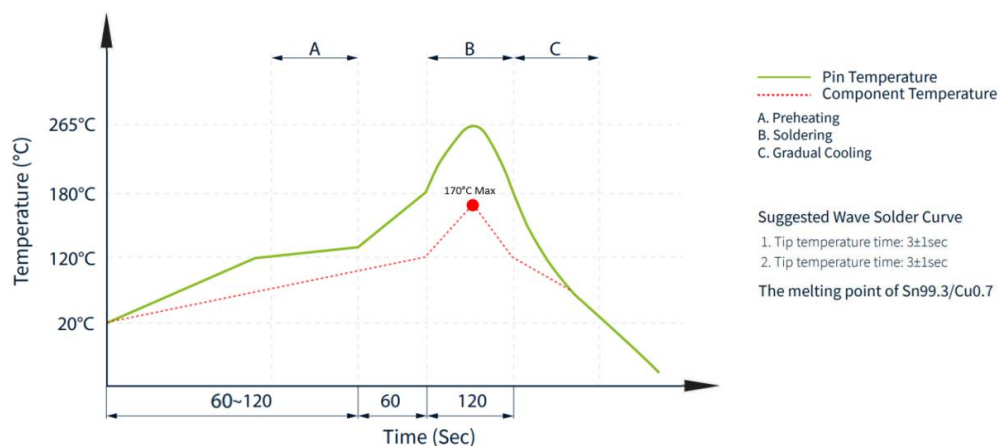

5. Packaging

5.1 SPQ

1 tray = 50 pcs

Tray dimension = 299x163x23mm

Tray weight = 0.3393 kg

5.2 Carton

1 Carton = 24 trays = 1200 pcs

Carton dimensions = 300*370*300 mm

Carton Weight = 8.8 kg

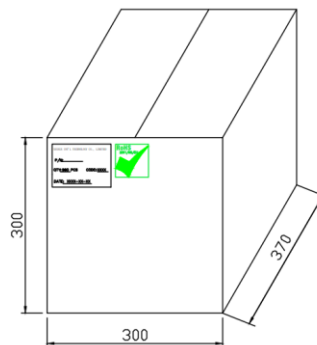

5.3 Label

Taoglas Limited	
P/N NO: XXXXXXXX	
QYT: XXX PCS	DC: XXXX
DATE: XXXX-XX-XX	

SPQ Label (8x4cm)

Taoglas Limited	
P/N NO: XXXXXXXX	
PO: XXXXXXXX	B/N: XXXXXXXX
QYT: XXX PCS	DC: XXXX
DATE: XXXX-XX-XX	

Carton Label (8x4cm)

Changelog

Changelog for the datasheet

SPE-24-8-123 – TMJG4813-8KGDNL4

Revision: A (Original First Release)

Date:	2024-06-30
Notes:	
Author:	Javier Vasena

Previous Revisions



www.taoglas.com

